

TABLE OF CONTENTS

I. CARE AND MAINTENANCE	2
II. TOOLS / MATERIALS, SEALANT REQUIREMENTS, & LOAD / ANCHOR INSTRUCTIONS	2
III. ASSEMBLY AND INSTALLATION	2
IV. ARCHE-DUCT BLOCK OUT	3
V. OPENING, FRAME AND PANEL VERIFICATION	4
1. Opening Verification	4
2. Pre-Fit and Leveling	4
3. Flash the Opening	4
4. Arche-Duct Water Test.....	5
5. Arche-Duct Install.....	5
6. Confirm Weeping Slots	5
7. Backfill	5
VI. FRAME ASSEMBLY	5
VII. NAIL-FIN FRAME INSTALLATION	6
VIII. BLOCK FRAME INSTALLATION	7
IX. PANEL ASSEMBLY (WHEN PANELS RECEIVED UNASSEMBLED)	8
X. ARCHETYPE FLOOR PIVOT (AFP) INSTALLATION	9
XI. PANEL INSTALLATION	10
XII. GLAZING INSTRUCTIONS PER GLASS (SKIP IF PANEL IS FACTORY GLAZED).	11
XIII. FINISHED FLOORING INSTALLATION	12
XIV. FLASHING AFTER INSTALLATION	12
APPENDIX A: PANEL SQUARING	13
APPENDIX B: HARDWARE LOCATIONS	14
APPENDIX C: ADJUSTING CLOSER SPEED	15
APPENDIX D: ARCHETYPE FLOOR PIVOT – REMODEL (AFP-R)	16
APPENDIX E: CLIC GLASS INSTALLATION	17

I. Care and Maintenance

Operational Warning: Fleetwood products operate smoothly and special care should be taken by the owner to make sure users are not injured.

This product is factory finished. Please handle with extreme care. Protect all exposed surfaces from contact with caustics, corrosives, solvents, abrasions, impacts, wet packing material etc.

FAILURE TO DO SO WILL NULLIFY THE WARRANTY. Before **ANY CLEANING**, review the Care & Maintenance Instructions (go to www.fleetwoodusa.com for more information). **Contact the local dealer with any questions or concerns.** Fleetwood strongly recommends that all products be cleaned after installation and totally protected from construction debris and equipment.

II. Tools / Materials, Sealant Requirements, & Load / Anchor Instructions

Tools Required: Tape measure, Soft mallet, Plumb bob / line, Flat head screwdriver, Laser Level or 8' level, Shims, Nails, Screws, Sealant, caulk gun, Backer Rod, Scissors or utility knife, hex key (3mm), drill bit, drive bit and powered drill.

Sealant Requirements

- The sealant referred to within this document for seals associated with the assembly of the product should conform to **AAMA 800**. It is recommended that all other sealants conform to **AAMA 800** but may be a sealant recommended and approved by the sealant manufacturer that is compatible with the framing, finish, and surrounding materials.
- All sealant bead sizes must conform to the sealant manufacturers' size requirements.
- The Owner / General Contractor is responsible for identifying the need for any additional sealant to be applied by others. Such sealant shall be elastomeric material, with the framing, finish and surrounding materials.

Load / Anchor Instructions

- Live or Dead Loads can affect product functionality, loads shall be designed to withstand the most critical effects of load factors and load combinations as required by building code.
- Fleetwood requires maximum vertical deflection of the header not to exceed $\text{Span}/720$ or $1/8''$
- Structural engineer to determine anchor quantity and spacing for design load requirements.
- Review panel pressure loads and lateral force with flooring manufacturers specifications.
- Proper material must be used between all dissimilar materials (i.e. block/concrete & aluminum).

III. Assembly and Installation

General: The key to any window or door installation is preparation. This extends from storage of the product to the final installation and to all points in between. Careful planning and attention to detail can help ensure proper installation.

It is essential that each Fleetwood product be assembled and glazed in accordance with AAMA standards and factory instructions. It is the installer's responsibility to ensure that each Fleetwood product is assembled, glazed and installed and completely sealed to ensure that the product is leak-free and operates correctly. **Installation of Fleetwood products must be in accordance with the standards set forth in ASTM E 2112.** If there are any questions regarding the installation of a Fleetwood product contact the factory customer service department.

Fleetwood has provided this product with recommended field glazed weather-stripping. If the provided weather-stripping does not ensure an optimum fit of glass to frame the Fleetwood Authorized Dealer should contact Customer Service for an expedited NO CHARGE shipment of replacement weather-stripping.

IV. Arche-Duct Block Out

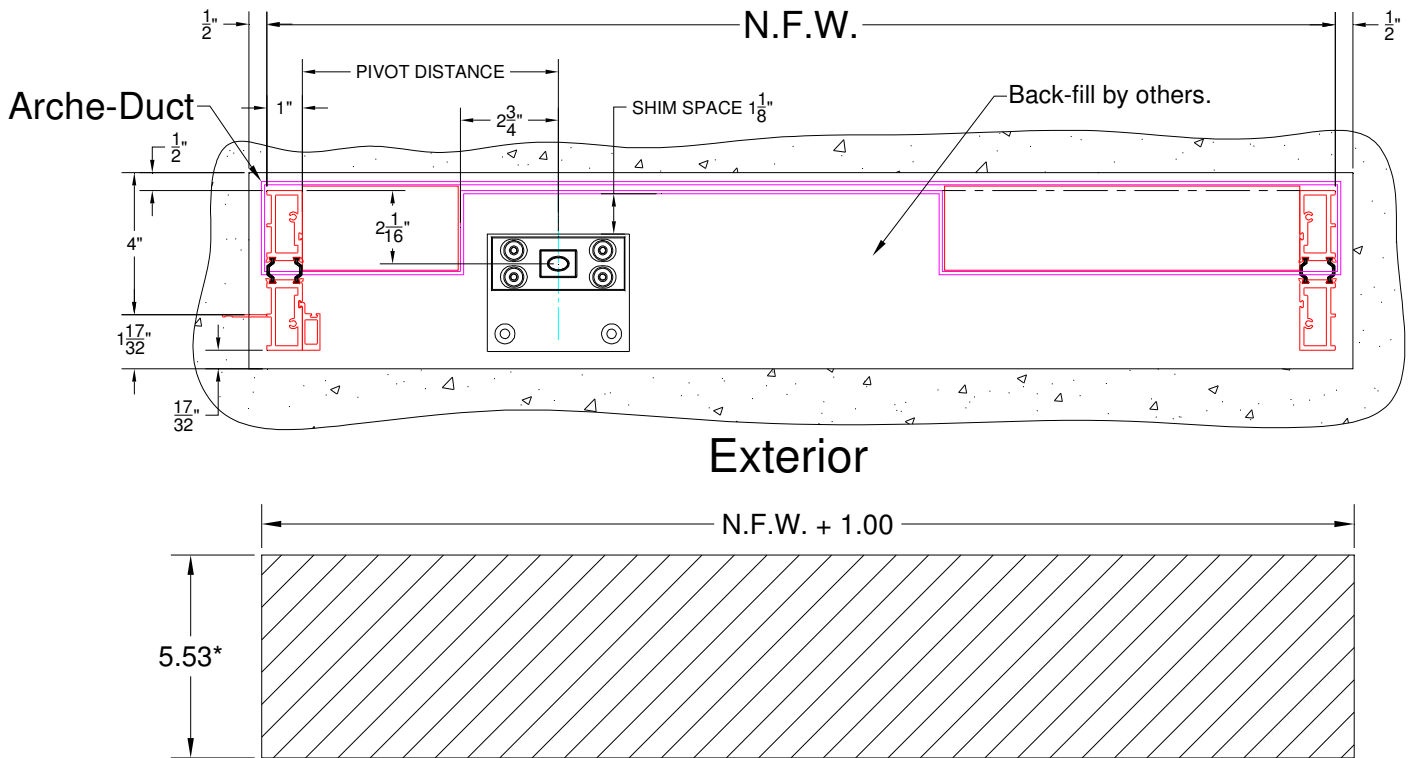

* = Arche-Duct tabs require additional blocking.

Figure 1:
Arche-Duct Block Out (Top View)

Archetype Floor Pivot to be installed PRIOR to finished floor.

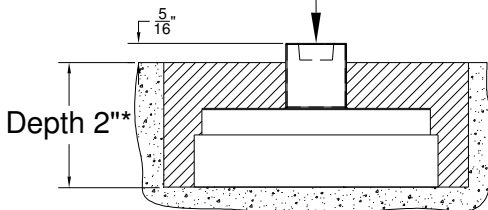

* Minimum depth required for Arche-Duct. Additional depth may be required for drainage setup. Side drains sit 3/16" below bottom of Arche-Duct.

Figure 2:
IRC Arche-Duct Depth Requirement (Side View)

Non-Arche-Duct Block Out

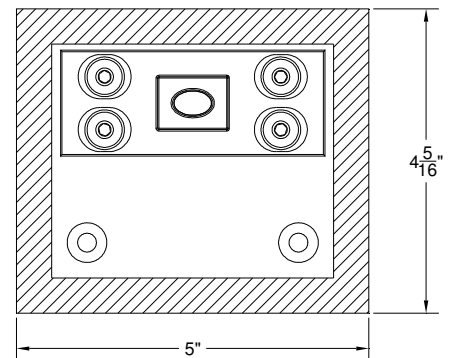

Figure 3:
Archetype Floor Pivot Block Out (Top View)

V. Opening, Frame and Panel Verification

1. Opening Verification

- Check the measurements of the opening and verify that the door will fit into the opening. Measure all four sides of the opening to make sure it is 1/2" larger than the doors in width and 1/4" in height.
- Verify the opening is plumb, square, and level (Figure 4).
- Verify location / dimension Arche-Duct opening (Figure 1,2).
- Remove the frame from packaging (save all red bag items for use later) and lay it in front of the opening. Check door net frame width / height dimensions and verify pivot distance (per order).

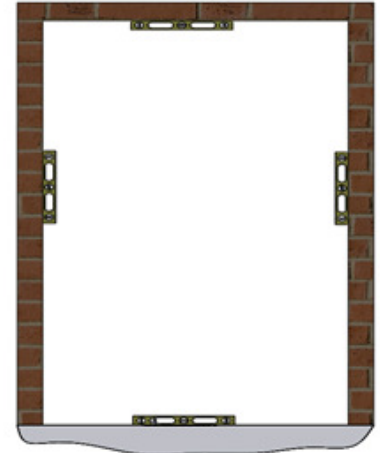

Figure 4:
Level Locations

2. Pre-Fit and Leveling

Note: Do not leave the Arche-Duct system exposed for more than 3 months. Prolonged exposure will damage the powder coated finish.

- Place the Arche-Duct drain system into the opening and determine any leveling that must be done prior to installation (Figure 4). Prepare relief areas for the PVC drain flange(s).
- Shim as necessary to stabilize the entire depth and length of the Arche-Duct. No unsupported width of more than 8" is allowed. Shim to be load bearing, non-porous, non-absorbent and inorganic.
- If more than 1/8" shim height is required, it is recommended that pouring self-leveling "Rock Hard" (or equal) to achieve level and stable surface.

3. Flash the Opening

- Once the opening has been confirmed, flashing of the opening is required prior to Frame installation. Paper and/or liquid flashing methods are acceptable (see AAMA 711/714 for material requirements).
- Check local Building codes for any additional flashing requirements.

Paper Flashing

- At each Jamb the flashing paper should be cut at least 3" past the weep-screed or diado flashing and at least 6" above the head of the door. The flashing must wrap around the jamb and at least 3" back into the opening.
- At the Head run the flashing paper long enough to extend at least 3" past the jamb flashing and wrap around the Header at least 3" into the opening.

Liquid Flashing

- Follow the liquid flashing manufacturer instructions.

4. Arche-Duct Water Test

Note: Installer responsible for verifying the integrity of the Arche-Duct for water leakage and performance.

- Block all drain outlets and fill the Arche-Duct with water to verify the integrity of all seams and drain connections. Look for leak points, the water level of the Arche-Duct should remain constant. If the Arche-Duct passes water test, drain Arche-Duct and continue with installation of frame.

5. Arche-Duct Install

Note: Do not leave the Arche-Duct system exposed for more than 3 months. Prolonged exposure will damage the powder coated finish.

- Confirm proper orientation of Arche-Duct for tracks and drain location with customer order and/or dealer drawings.
- Install Arche-Duct into already leveled opening. An insulating material should be placed between the Arche-Duct and the supporting structure (concrete, steel, etc.) to prevent corrosion of the aluminum Arche-Duct.
- Connect tubing or pipe to Arche-Duct drain connections.

6. Confirm Weeping Slots

- Typical weep slot quantity to be 3 per single panel configuration.

7. Backfill

- Do not back-fill until door operation is fully tested, including locking into jamb(s) and locking into pocket interlocker (when applicable).
- Verify you have access to drainage connections and clean out as necessary.

VI. Frame Assembly

Note: Failure to assemble the frame according to the installation instructions, nullifies warranties related to this product.

- Apply a compatible sealant to the corners of the frame. Assemble the frame with screws provided (Figure 5).

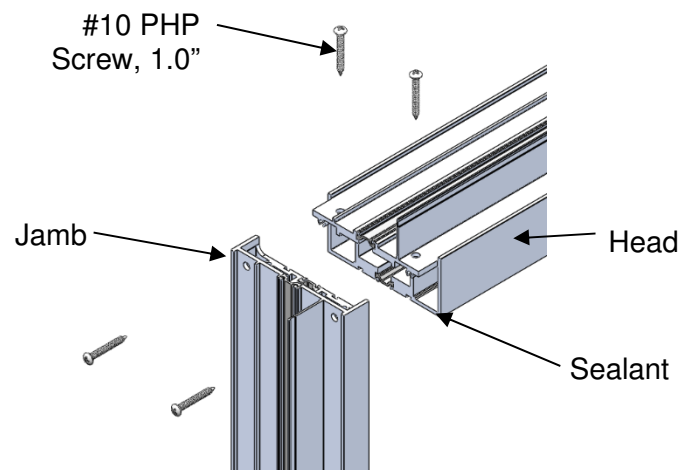

Figure 5:
Frame Assembly

VII. Nail-fin Frame Installation

Note: Fleetwood recommends the use of a laser level or 8' level for frame installations. Cross-measure within $\pm 1/32"$ for interior and exterior.

1. Seal frame and vent joints completely with compatible sealant.
2. Insert the frame into the Arche-Duct. Cross-measure and adjust to achieve a plumb square and level condition. Shim where needed. Seal all fastener heads with compatible sealant.
3. Secure Archetype Head Pivot to header with #10 screw min. 4" long (not by Fleetwood). See Figure 6 for illustration.
4. Archetype Floor Pivot Installation see Section IX.

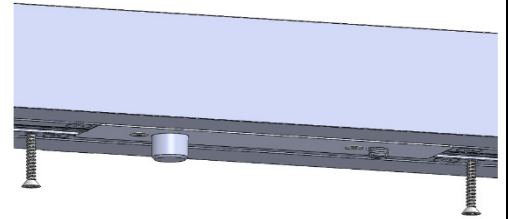

Figure 6:
Securing Archetype Head Pivot
(Nail-fin Frame Shown)

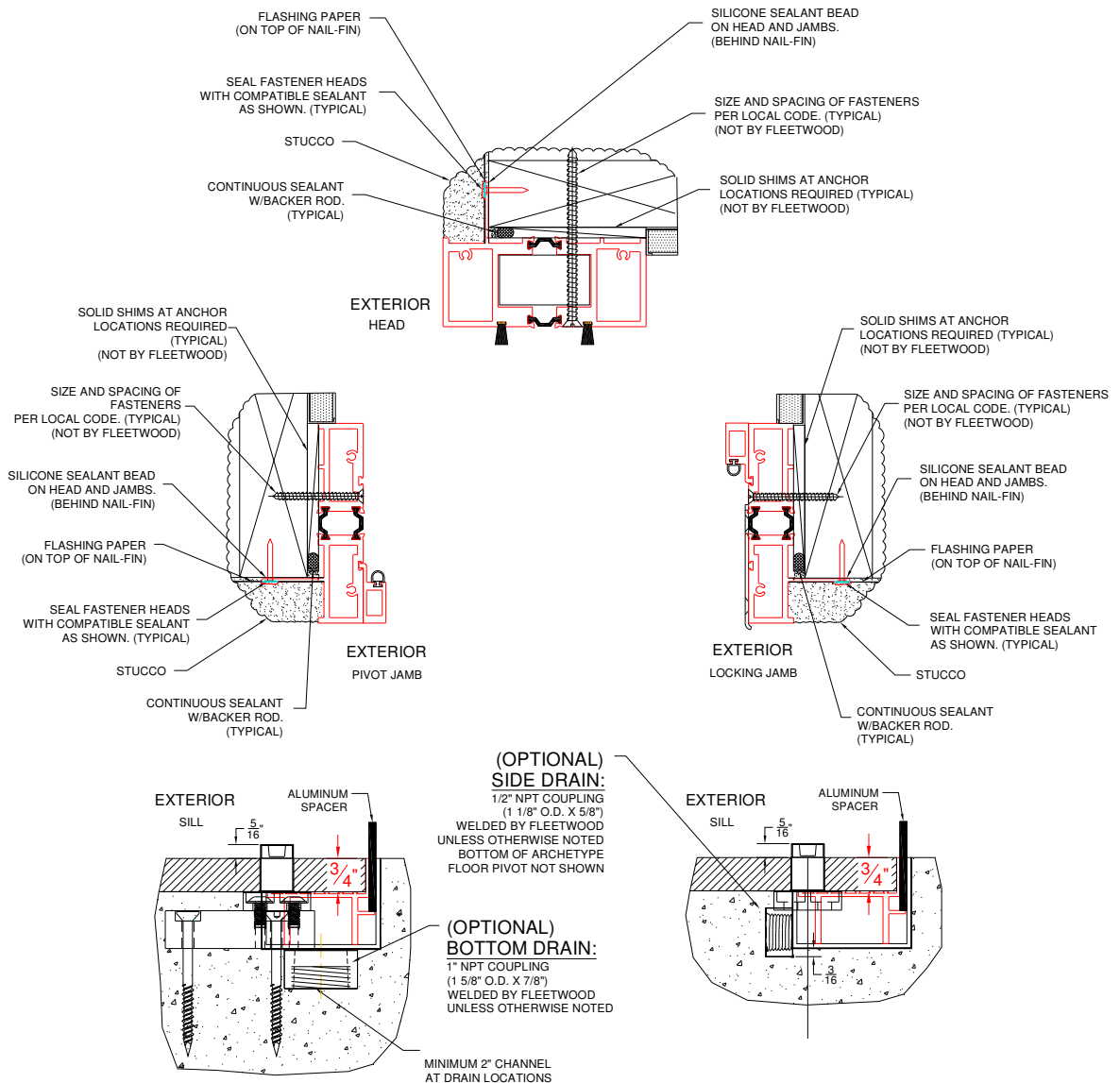

Figure 7:
IRC Nail-fin frame installation

VIII. Block Frame Installation

Note: Fleetwood recommends the use of a laser level or 8' level for frame installations. Cross-measure, tolerance is within $\pm 1/32"$ for interior and exterior.

1. Seal frame and vent joints completely with compatible sealant.
2. Insert the frame into the Arche-Duct. Cross-measure and adjust to achieve a plumb square and level condition. Shim where needed. Seal all fastener heads with compatible sealant.
3. Secure Archetype Head Pivot to header with #10 screw min. 4" long (not by Fleetwood). See Figure 8 for illustration.
4. Archetype Floor Pivot installation see Section IX.

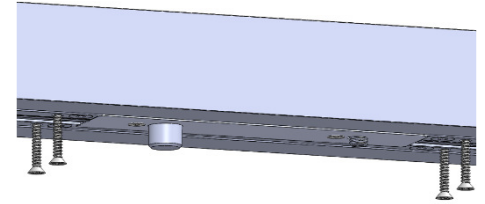

Figure 8:
Securing Archetype Head Pivot
(Block Frame Shown)

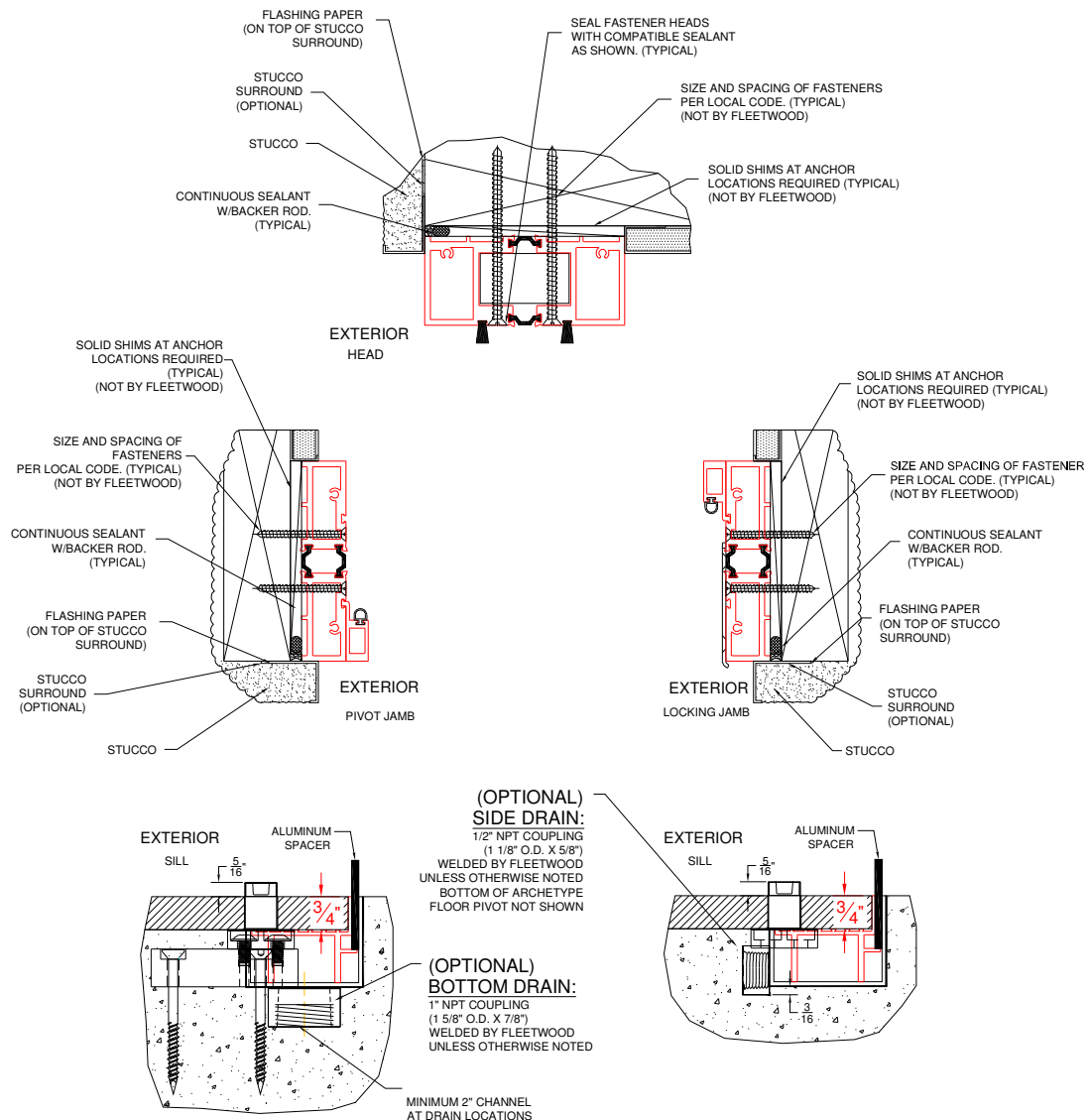

Figure 9:
IRC Block Frame Installation

IX. Panel Assembly (when panels received unassembled)

Note: Make sure to keep individual panel components together. Match door configuration and panel orientation with customer order and/or dealer drawings. Configuration and orientation of panels shown in assembly instructions is for illustration purposes only.

- Check the red (documents enclosed) bag for keys, nuts, washers, and back-up plate (Figure 10).
- Remove glass stops from panel components. Must be field cut to fit once panel is assembled covered in Section VII for panel mounting and glazing instructions.
- On the top and bottom rails cut the bulb vinyl a 1/4" long on both ends. Cut the bulb vinyl on the vertical stiles to length where they will make contact with the inner edge of the top and bottom rails.
- Remove nut, washer, and back-up plate from the red bag.
- Apply sealant to the top and bottom rail where they make contact with the vertical stiles (Figure 11).
- Align the vertical stiles to the top and bottom rail. Place the threaded rod into the pre-drilled holes of the vertical stiles.
- Apply a small amount of high strength threadlocker to the end of the threaded rod.
- Slide the back-up plate over the threaded rod. Followed by the washer and nut (Figure 12).
- Tighten down the nut until all components are securely making contact.
- See Appendix A for panel squaring.
- Place the weather seals into the seal clips and tap the clips into place.



Figure 10:
Red Bag

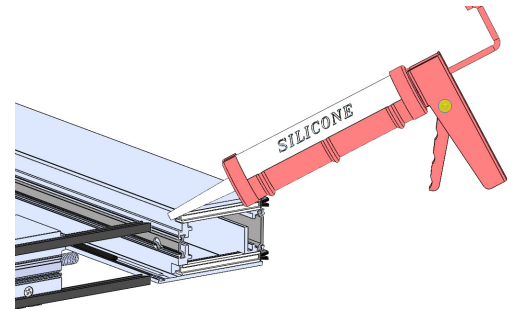

Figure 11:
Silicone Location

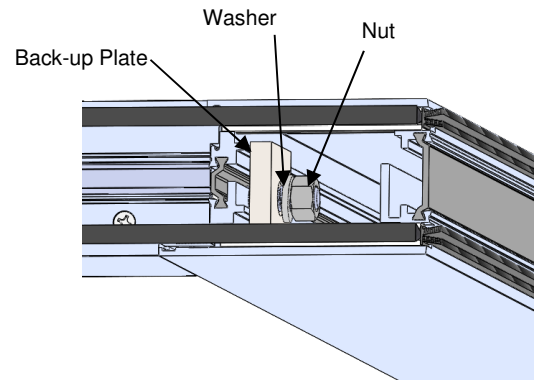

Figure 12:
Panel Assembly (Hinge Stile Shown)

X. Archetype Floor Pivot (AFP) Installation

CAUTION: Review flooring structural specifications prior to installation.

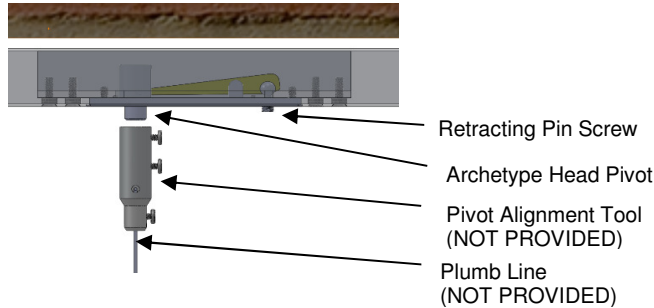
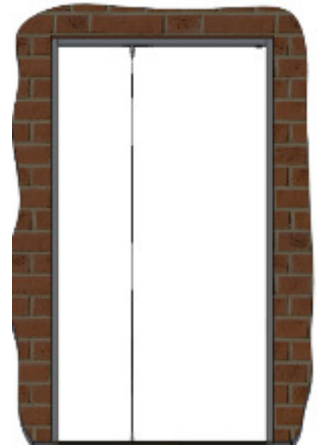
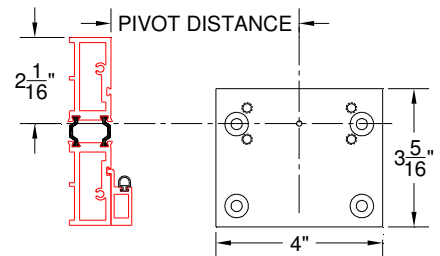

Figure 13:
In-line Verification



1. Positioning the AFP into blocked out area.
 - a. Use a plumb line to center the Archetype Floor Pivot location with the Archetype Head Pivot pin (Figure 13).
 - b. Assembled Archetype Floor Pivot (red bag attached to frame) to sit $5/16$ " above finished floor, backfill after installation (Figure 2).
 - c. The provided center location hole on the bottom section of the Archetype Floor Pivot is to be set back $2-1/16$ " from the interior face of the jamb and level (Figure 14).



Exterior
Figure 14:
Archetype Floor Pivot Positioning

2. Anchoring the AFP
 - a. Use a plumb line to center the Archetype Floor Pivot with the Archetype Head Pivot. Mark the anchor hole locations of the Archetype Floor Pivot.
 - b. Remove the Archetype Floor Pivot. If using the factory provided concrete screws, drill $2-1/2$ " deep (for concrete use a $3/16$ " dia. bit). Clean away excess debris.
 - c. Fasten to the floor (Figure 15), the bottom section of the Archetype Floor Pivot with the factory provided concrete anchor screws ($1/4$ " FHP Concrete screw, $3-1/4$ ").
3. Assemble the top section of the Archetype Floor Pivot using a $5/32$ " hex key (Figure 16). Verify and adjust the position of the Archetype Floor Pivot as necessary (Figure 17), retighten.
4. Note: Backfill Archetype Floor Pivot after panel and glazing installation / adjustments are performed.

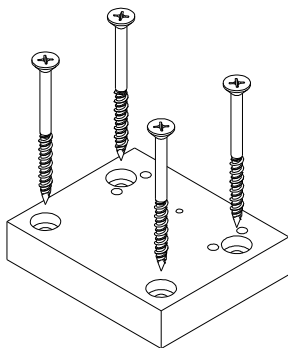

Figure 15:
Securing the Archetype Floor Pivot

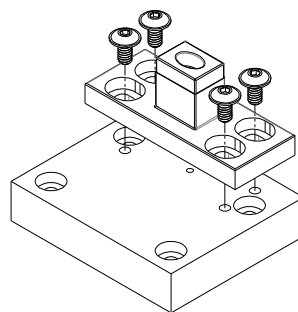

Figure 16:
Archetype Floor Pivot Assembly

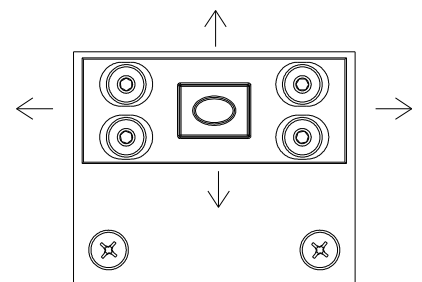
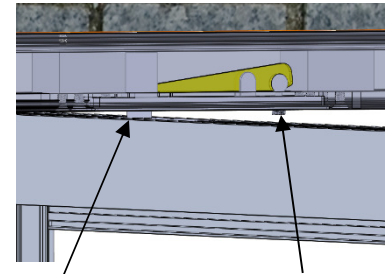

Figure 17:
Radial Adjustment

XI. Panel Installation

- **Panel Squaring** (troubleshooting tip) see Appendix A.
 - **Handle Pull Installation** see Appendix B.
 - **Closing Speed Adjustment** see Appendix C.
1. Retract Archetype Head Pivot pin by turning retracting pin screw counter clockwise (Figure 18).
 2. Ensure the closer is orientated correctly for installation with the Archetype Floor Pivot, the arrow should point to the closing side of the door (Figure 19). If needed, remove floor closer from bottom rail and use Archetype Floor Pivot (installed or with leverage) to orientate correctly.



Archetype Head Pivot Retracting Pin Head Pivot

Figure 18:
Archetype Head Pivot Locking



CORRECT
Pivot Right Outswing
Pivot Left Inswing

CORRECT
Pivot Right Inswing
Pivot Left Outswing

Figure 19:
Closer Orientation (Bottom View Shown)

CAUTION: Do not apply any pressure on the glass stop side of the bottom rail.

3. Place the panel perpendicular to the frame and lift into the opening.
4. Align panel closer with Archetype Floor Pivot and lower.
5. Align the two portions of the Archetype Head Pivot and turn the retracting pin screw clockwise (Figure 18).
6. Square and aligned the panel with the frame (as necessary).
7. The installer is responsible for the integrity of all framing joints after installation and must therefore water test all joints to guarantee a completely sealed product. Apply joint sealer and/or sealant necessary to ensure watertight joints. Retest as necessary.
8. To complete the panel installation, apply backer rod and a complete bed of sealant to the entire exterior and interior joint between the frame and the building structure. Tool the sealant to eliminate bubbles, voids and / or breaks and ensure a completely watertight seal (Figure 7,9).
9. Note: Backfill Archetype Floor Pivot after panel and glazing installation / adjustments are performed.

XII. Glazing Instructions per Glass (Skip if panel is factory glazed).

1. Remove the precut glass stops from the frame, making sure to note the location from which each has been removed. Each stop is cut for a specific location and must be returned to the same location after the glazing process.
2. Before glazing, apply a 1/4"×1/4"×6" bead of compatible sealant from each corner on inner flange of panel (Figure 20).

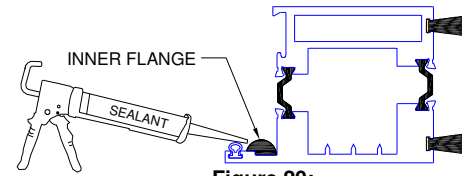

Figure 20:
Sealant Location (Top Rail Shown)

Note: For panel heights over 8 feet tall Fleetwood recommends an additional 24" of compatible sealant be applied halfway up on the vertical stiles.

3. Insert the setting blocks (red bag) according to the image that more closely resembles the product (Figure 21 or 22).
4. Stagger setting blocks accordingly to support glass lites at the bottom pivot location.
5. Insert glass into panel.
6. Cross-measure to ensure the panel is square. See Appendix A for troubleshooting tip on how to square the panel.
7. Finish assembly by inserting the two horizontal glass stops then install the two vertical glass stops.
8. Note: Backfill Archetype Floor Pivot after panel and glazing installation / adjustments are performed.

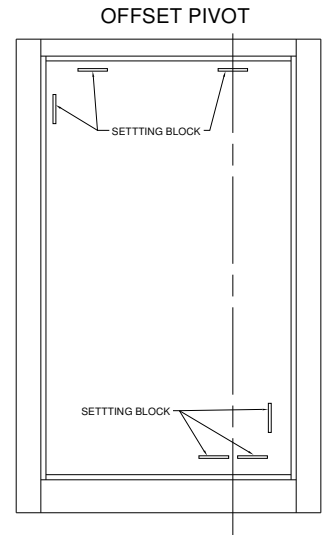

Figure 21:
Offset Pivot Location Setting Blocks
(Pivot Location Right Shown)

Alternate Glazing Procedure

Note: Applies to outside glazed where additional water sealant is required.

1. Apply a continuous 1/4"×1/4" bead of sealant before glazing. (Figure 20).
2. Insert the setting blocks (red bag) according to the image that more closely resembles the product (Figure 21 or 22).
3. Stagger setting blocks accordingly to support glass lites at the bottom pivot location.
4. Insert glass into panel.
5. Cross-measure to ensure the panel is square. See Appendix A for troubleshooting tip on how to square the panel.
6. Insert the two horizontal glass stops then install the two vertical glass stops.
7. Apply a bead of compatible sealant along the glass and glass stop edge.
8. Note: Backfill Archetype Floor Pivot after panel and glazing installation / adjustments are performed.

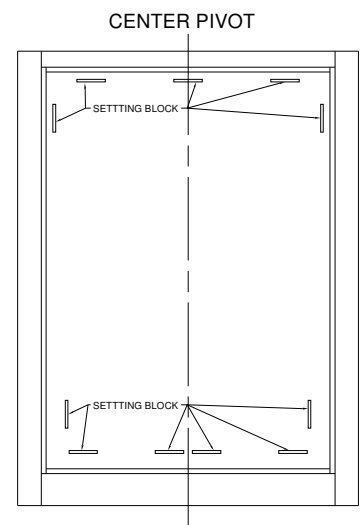

Figure 22:
Center Pivot Location Setting Blocks

XIII. Finished Flooring Installation

Flooring Material: The sill for this product was designed to incorporate the finished flooring as a key component to the bottom rail sealing and the linear slot drain. The material chosen to surround the extruded sill should be such that water will not damage it.

Linear Slot drain: The sill comes with an aluminum spacer to ensure the linear slot drain spacing is correct. This spacer is to be removed after the flooring is installed.

XIV. Flashing after Installation

The flashing paper referred to in this document is Moistop or other code compliant flashing material that conforms to **Federal Specification UU-B-790a, Type 1, Grade A, Style 4**. The strips of flashing paper are to be no less than 9 inches wide (or wider as required by local codes). Flashing paper must be applied with galvanized nails or corrosion resistant staples. Flashing paper shall be applied in a weatherboard fashion around the full perimeter of the framed opening.

1. Once satisfied that the frame is water tight, and immediately prior to application of the flashing paper at the head and jambs, apply a continuous bead of sealant to the exposed mounting flange (nail-fin) at the top (head) and sides (jambs) of the installed frame. Also, apply sealant at corners of the frame, the full length of the seams where the nail fin flashing is mounted.
2. At each jamb, embed the flashing paper into the sealant onto mounting flange and fasten into place. The flashing paper should be cut sufficiently long enough to extend at least 3" past the weep-screed or diado flashing and at least 6 inches above the head of the window (Figure 23).
3. Finally, at the head, embed the flashing into the sealant on the mounting flange and fasten into place. The flashing paper should be cut sufficiently long enough to extend past the flashing paper at each jamb by at least 3" (Figure 24).
4. Weather resistant building paper should be applied in a weatherboard fashion to complete the installation (Figure 25).

Note: Where weather resistant building paper, insulating board, or other materials by other trades may constitute the primary weather barrier behind the exterior wall finish (i.e. stucco, masonry, siding, etc.), the owner / General Contractor are responsible to ensure that the weather barrier is continuous by effectively sealing the material to the window frame.

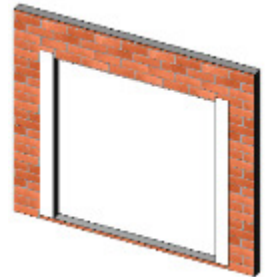

Figure 23:
Jamb flashing



Figure 24:
Head Flashing

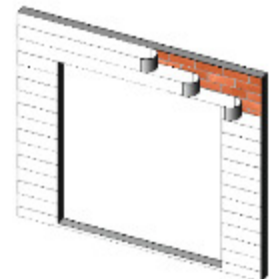

Figure 25:
Building Flashing

Appendix A: Panel Squaring

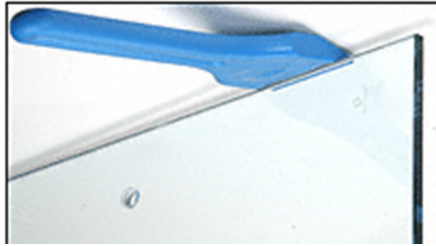

Figure A1:
Glass Lifting Tool

Required Tools: 9/16" wrench, pliers, tape measure, shim, plate glass lifting tool.

1. If panel hits the sill due to the weight of glass/panel.
 - a. Make sure the frame is squared before any adjustment to panel.
 - b. If the problem is solved, stop here.
 - c. Lay panel on table and check distance of both diagonals. If they are not the same, the panel is not square.
 - d. Loosen nuts at 4 corners (2 turns), use plate glass lifting tool and add additional shim(s) to the top of the panel opposite of the pivot, between the glass and vent top rail.
 - e. Check diagonal distances, gap of panel to frame.
 - f. Tighten corner key nuts.
2. If panel hits the head.
 - a. Make sure the frame is squared before any adjustment to panel.
 - b. If the problem is solved, stop here.
 - c. Lay panel on table and check distance of both diagonals. If they are not the same, the panel is not square.
 - d. Loosen nuts at 2 top corners (2 turns), use plate glass lifting tool and remove/replace current shims with thinner shims to the top of the panel opposite of the pivot, between the glass and vent top rail.
 - e. Check diagonal distances, gap of panel to frame.
 - f. Tighten corner key nuts.

Appendix B: Hardware Locations

The following are latching hardware locations to avoid when installing **surface mount handle pulls**.

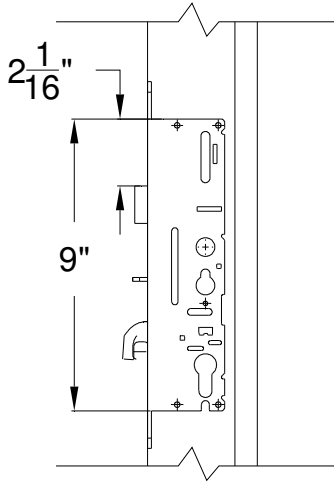

Figure B1:
2 Point Latch

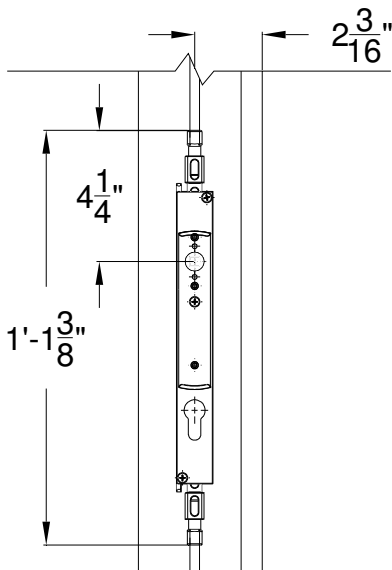

Figure B2:
DPL

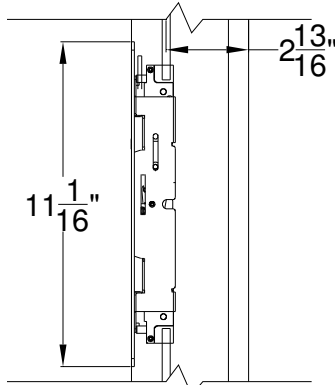

Figure B3:
Inactive Panel Shoot-bolts

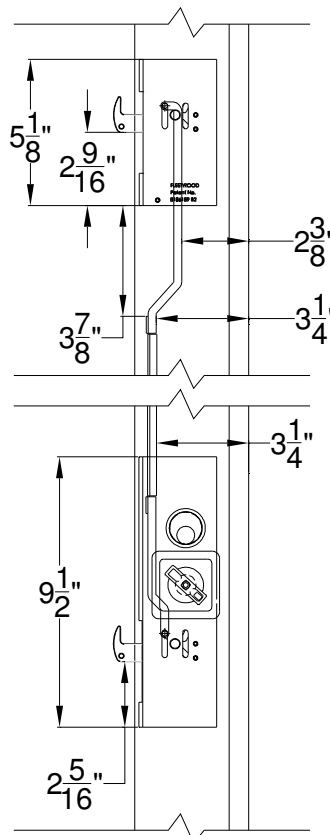

Figure B4:
Archetype Latch and Secondary Latch

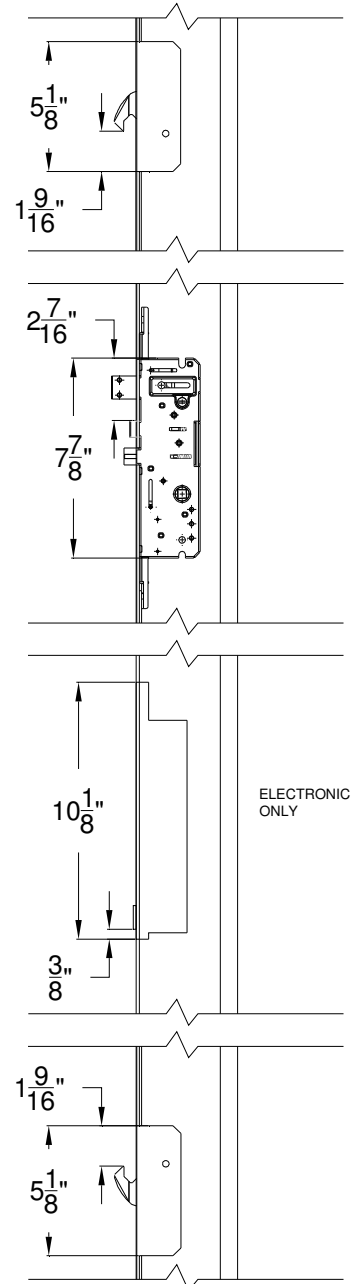
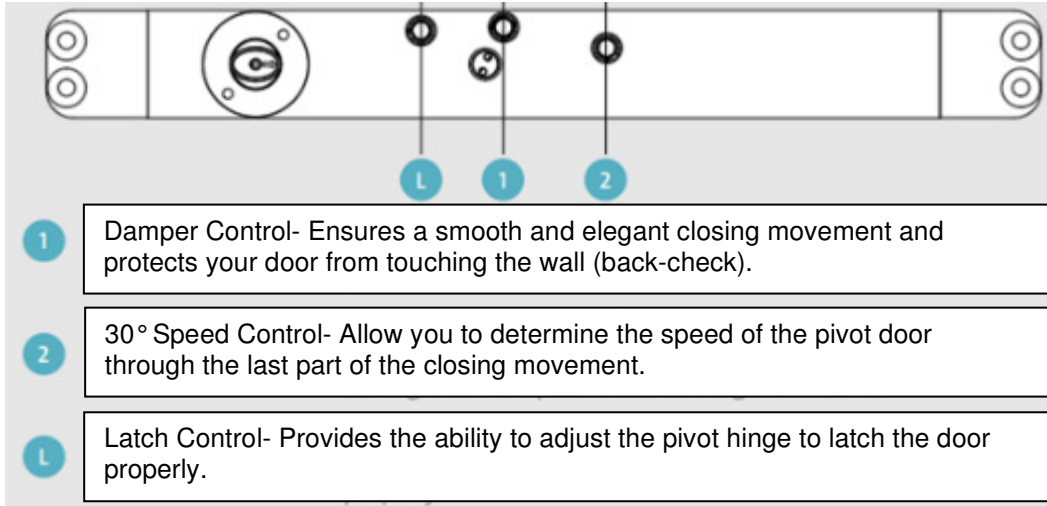

Figure B5:
5 Point Latch / Electronic Latch

Appendix C: Adjusting Closer Speed

To adjust the closer speed, use the (5mm) open ended wrench provided with the AFP. In some cases, removal of the panel may be necessary. See images below for more details. Clockwise will reduce the closing speed. Counter-Clockwise will increase the closing speed.



DAMPER CONTROL

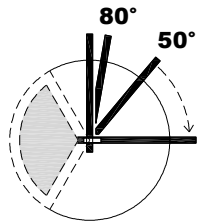

Damper Control has two functions. The hydraulic back-check protects the pivot door against touching the wall by providing adjustable resistance as the approaches the 80° position. The closing damping makes the door close smoothly.

30° SPEED CONTROL

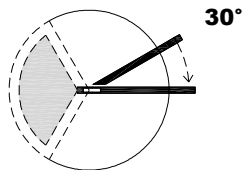

30° Speed Control allows you to fine-tune the speed of the pivot door through the last 30° of the closing movement.

LATCH CONTROL

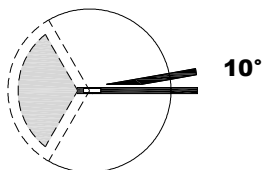

Latch Control provides the ability to adjust the closing speed to latch the door properly. Latch Control enables the door to accelerate in the last 10° to ensure proper latching of the door.

Figure C1:
Closer Adjustment Illustrations

Appendix D: Archetype Floor Pivot – Remodel (AFP-R)

1. The AFP-R requires a flooring block out.

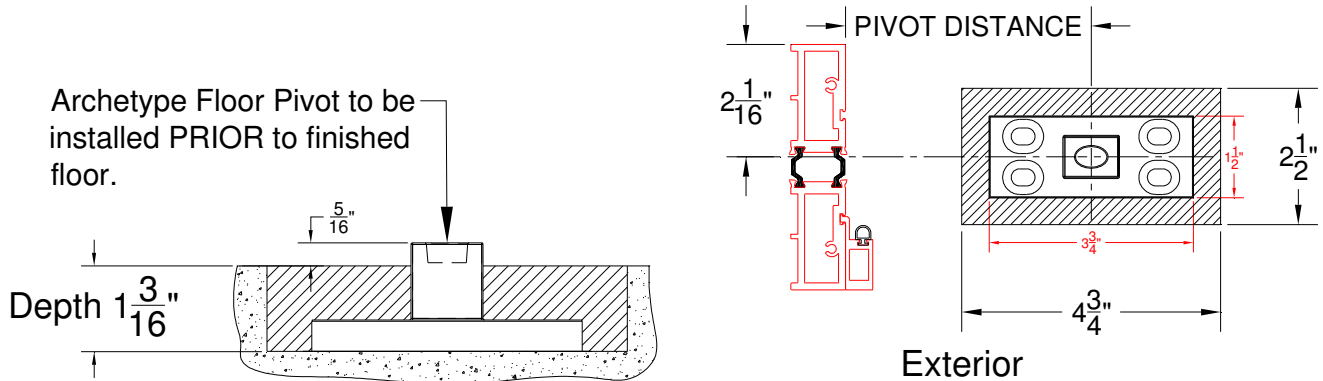

Figure D1:
AFP-R Block Out and Positioning

2. Positioning the AFP-R into blocked out area.
 - a. Use a plumb line to center the AFP-R location with the Archetype Head Pivot pin. AFP-R to be parallel with frame.
 - b. Top of AFP-R (red bag attached to frame) to sit 5/16" above finished floor, backfill after installation (Figure D1).
 - c. The center of the AFP-R is to be 2-1/16" from the interior face of the jamb and level (Figure D1).
3. Anchoring the AFP-R
 - a. Use a plumb line to center the AFP-R with the Archetype Head Pivot. Mark the anchor hole locations.
 - b. Remove the AFP-R. Drill into substrate. Clean away excess debris.
 - c. Fasten the AFP-R into the substrate.
 - d. Verify and adjust the position of the AFP-R as necessary.
4. Note: Backfill AFP-R after panel and glazing installation / adjustments are performed.

Appendix E: CLiC Glass Installation

Fleetwood offers CLiC on demand Privacy Glass as a glazing option. This type of glazing option requires power to be run to each lite using cardinals proprietary glass controller. Depending on the type of product ordered, the wire leads locations will vary. Please ask at the time of purchase to confirm where these leads will be located so assist in preparing the opening accordingly.

Below are links to CLiC glass specific installation instructions:

[Quick Start Guide](#)

[Installation Manual](#)

[Technical Data Sheet](#)