

**TABLE OF CONTENTS**

<b>I. CARE AND MAINTENANCE.....</b>	<b>2</b>
<b>II. TOOLS / MATERIALS, SEALANT REQUIREMENTS, &amp; LOAD / ANCHOR INSTRUCTIONS .....</b>	<b>2</b>
<b>III. ASSEMBLY AND INSTALLATION .....</b>	<b>2</b>
<b>IV. ARCHE-DUCT BLOCK OUT .....</b>	<b>3</b>
<b>V. OPENING, FRAME AND PANEL VERIFICATION .....</b>	<b>4</b>
1. Opening Verification.....	4
2. Pre-Fit and Leveling.....	4
3. Flash the Opening.....	4
4. Arche-Duct Water Test .....	5
5. Arche-Duct Install .....	5
6. Confirm Weeping Slots .....	5
7. Backfill .....	5
<b>VI. FRAME ASSEMBLY .....</b>	<b>5</b>
<b>VII. NAIL-FIN FRAME INSTALLATION.....</b>	<b>6</b>
<b>VIII. BLOCK FRAME INSTALLATION.....</b>	<b>7</b>
<b>IX. ARCHETYPE FLOOR PIVOT (AFP) INSTALLATION.....</b>	<b>8</b>
<b>X. PANEL INSTALLATION.....</b>	<b>9</b>
<b>XI. FINISHED FLOORING INSTALLATION.....</b>	<b>10</b>
<b>XII. FLASHING AFTER INSTALLATION.....</b>	<b>10</b>
<b>APPENDIX A: HARDWARE LOCATIONS.....</b>	<b>11</b>
<b>APPENDIX B: ADJUSTING CLOSER SPEED .....</b>	<b>12</b>
<b>APPENDIX C: ARCHETYPE FLOOR PIVOT – REMODEL (AFP-R) .....</b>	<b>13</b>

## I. Care and Maintenance

**Operational Warning:** Fleetwood products operate smoothly and special care should be taken by the owner to make sure users are not injured.

Prior to installation, store the door in a dry flat level surface that is elevated. **DO NOT** lean doors against walls (to prevent warping). **AVOID** contact with the ground, moisture, direct sunlight, or extreme temperatures during storage.

This product is factory finished. Please handle with extreme care. Protect all exposed surfaces from contact with caustics, corrosives, solvents, abrasions, impacts, wet packing material etc. **FAILURE TO DO SO WILL NULLIFY THE WARRANTY.** Before **ANY CLEANING**, review the Care & Maintenance Instructions (go to [www.fleetwoodusa.com](http://www.fleetwoodusa.com) for more information). **Contact the local dealer with any questions or concerns.** Fleetwood strongly recommends that all products be cleaned after installation and totally protected from construction debris and equipment.

**After Installation** to prevent warping and cracking of the wood, avoid exposing the door to direct sunlight or humidity for prolonged periods. Wood naturally expands and contracts with temperature and humidity changes. To minimize these issues ensure the door is installed in an area with moderate and stable environmental conditions.

## II. Tools / Materials, Sealant Requirements, & Load / Anchor Instructions

**Tools Required:** Tape measure, Soft mallet, Plumb bob / line, Flat head screwdriver, Laser Level or 8' level, Shims, Nails, Screws, Sealant, caulk gun, Backer Rod, Scissors or utility knife, drill bit, 5/32" hex key, drive bit and powered drill.

### Sealant Requirements

- The sealant referred to within this document for seals associated with the assembly of the product should conform to **AAMA 800**. It is recommended that all other sealants conform to **AAMA 800** but may be a sealant recommended and approved by the sealant manufacturer that is compatible with the framing, finish, and surrounding materials.
- All sealant bead sizes must conform to the sealant manufacturers' size requirements.
- The Owner / General Contractor is responsible for identifying the need for any additional sealant to be applied by others. Such sealant shall be elastomeric material, with the framing, finish and surrounding materials.

### Load / Anchor Instructions

- Live or Dead Loads can affect product functionality, loads shall be designed to withstand the most critical effects of load factors and load combinations as required by building code.
- Fleetwood requires maximum vertical deflection of the header not to exceed  $\text{Span}/720$  or  $1/8"$ .
- Structural engineer to determine anchor quantity and spacing for design load requirements.
- Review panel pressure loads and lateral force with flooring manufacturers specifications.
- Proper material must be used between all dissimilar materials (i.e. block/concrete & aluminum).

## III. Assembly and Installation

**General:** The key to any window or door installation is preparation. This extends from storage of the product to the final installation and to all points in between. Careful planning and attention to detail can help ensure proper installation.

It is essential that each Fleetwood product be assembled in accordance with AAMA standards and factory instructions. It is the installer's responsibility to ensure that each Fleetwood product is assembled, installed and completely sealed to ensure that the product is leak-free and operates correctly. Installation of Fleetwood products must be in accordance with the standards set forth in ASTM E 2112. If there are any questions regarding the installation of a Fleetwood product contact the factory customer service department.

Fleetwood has provided this product with recommended weather-stripping. If the provided weather-stripping does not ensure an optimum fit the Fleetwood Authorized Dealer should contact Customer Service for an expedited NO CHARGE shipment of replacement weather-stripping.

**IV. Arche-Duct Block Out**

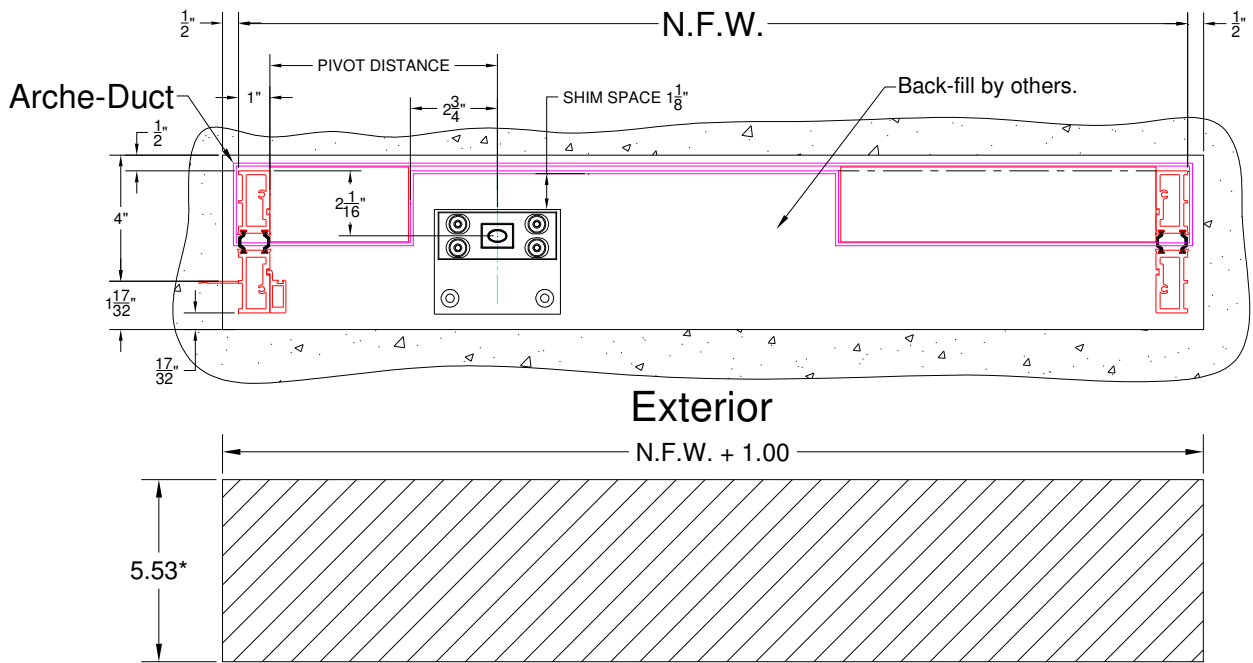

\* = Arche-Duct tabs require additional blocking.

**Figure 1:**  
Arche-Duct Block Out (Top View)

Archetype Floor Pivot to be installed PRIOR to finished floor.

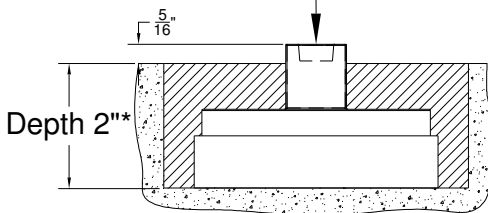

\* Minimum depth required for Arche-Duct. Additional depth may be required for drainage setup. Side drains sit 3/16 inch below bottom of Arche-Duct.

**Figure 2:**  
IRC Arche-Duct Depth Requirement (Side View)

Non-Arche-Duct Block Out

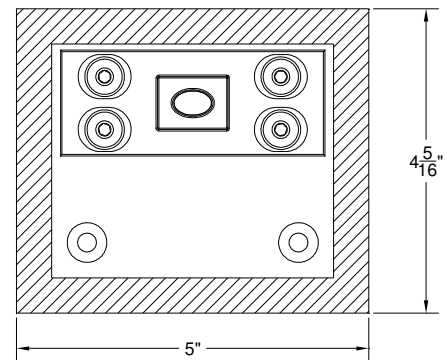
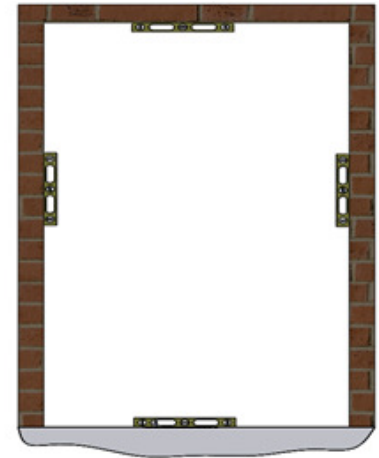

**Figure 3:**  
Archetype Floor Pivot Block Out (Top View)

## V. Opening, Frame and Panel Verification

### 1. Opening Verification

- Check the measurements of the opening and verify that the door will fit into the opening. Measure all four sides of the opening to make sure it is 1/2" larger than the doors in width and 1/4" in height.
- Verify the opening is plumb, square, and level (Figure 4).
- Verify location / dimension Arche-Duct opening (Figure 1,2).
- Remove the frame from packaging (save all red bag items for use later) and lay it in front of the opening. Check door net frame width / height dimensions and verify pivot distance (per order).



**Figure 4:**  
Level Locations

### 2. Pre-Fit and Leveling

**Note:** Do not leave the Arche-Duct system exposed for more than 3 months. Prolonged exposure will damage the powder coated finish.

- Place the Arche-Duct drain system into the opening and determine any leveling that must be done prior to installation (Figure 4). Prepare relief areas for the PVC drain flange(s).
- Shim as necessary to stabilize the entire depth and length of the Arche-Duct. No unsupported width of more than 8" is allowed. Shim to be load bearing, non-porous, non-absorbent and inorganic.
- If more than 1/8" shim height is required, it is recommended that pouring self-leveling "Rock Hard" (or equal) to achieve level and stable surface.

### 3. Flash the Opening

- Once the opening has been confirmed, flashing of the opening is required prior to Frame installation. Paper and/or liquid flashing methods are acceptable (see AAMA 711/714 for material requirements).
- Check local Building codes for any additional flashing requirements.

#### Paper Flashing

- At each Jamb the flashing paper should be cut at least 3" past the weep-screed or diado flashing and at least 6" above the head of the door. The flashing must wrap around the jamb and at least 3" back into the opening.
- At the Head run the flashing paper long enough to extend at least 3" past the jamb flashing and wrap around the Header at least 3" into the opening.

#### Liquid Flashing

- Follow the liquid flashing manufacturer instructions.

#### 4. Arche-Duct Water Test

**Note:** Installer responsible for verifying the integrity of the Arche-Duct for water leakage and performance.

- Block all drain outlets and fill the Arche-Duct with water to verify the integrity of all seams and drain connections. Look for leak points, the water level of the Arche-Duct should remain constant. If the Arche-Duct passes water test, drain Arche-Duct and continue with installation of frame.

#### 5. Arche-Duct Install

**Note:** Do not leave the Arche-Duct system exposed for more than 3 months. Prolonged exposure will damage the powder coated finish.

- Confirm proper orientation of Arche-Duct for tracks and drain location with customer order and/or dealer drawings.
- Install Arche-Duct into already leveled opening. An insulating material should be placed between the Arche-Duct and the supporting structure (concrete, steel, etc.) to prevent corrosion of the aluminum Arche-Duct.
- Connect tubing or pipe to Arche-Duct drain connections.

#### 6. Confirm Weeping Slots

- Typical weep slot quantity to be 3 per single panel configuration.

#### 7. Backfill

- Do not back-fill until door operation is fully tested, including locking into jamb(s) and locking into pocket interlocker (when applicable).
- Verify you have access to drainage connections and clean out as necessary.

### VI. Frame Assembly

**Note:** Failure to assemble the frame according to the installation instructions, nullifies warranties related to this product.

- Apply a compatible sealant to the corners of the frame. Assemble the frame with screws provided (Figure 5).

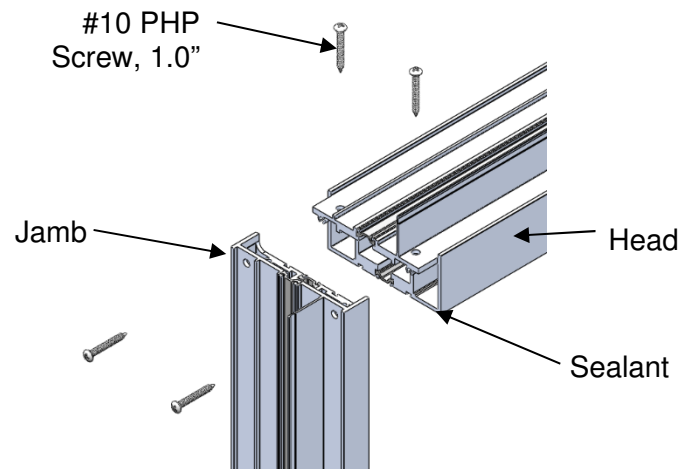
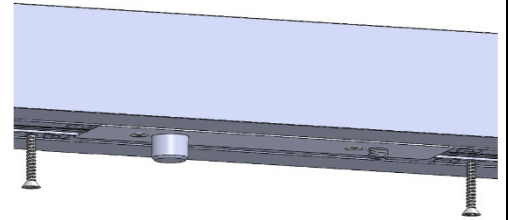

**Figure 5:**  
Frame Assembly

### VII. Nail-fin Frame Installation

**Note:** Fleetwood recommends the use of a laser level or 8' level for frame installations. Cross-measure within  $\pm 1/32"$  for interior and exterior.

1. Seal frame and vent joints completely with compatible sealant.
2. Insert the frame into the Arche-Duct. Cross-measure and adjust to achieve a plumb square and level condition. Shim where needed. Seal all fastener heads with compatible sealant.
3. Secure Archetype Head Pivot to header with #10 screw min. 4" long (not by Fleetwood). See Figure 6 for illustration.
4. Archetype Floor Pivot Installation see Section IX.



**Figure 6:**  
Securing Archetype Head Pivot  
(Nail-fin Frame Shown)

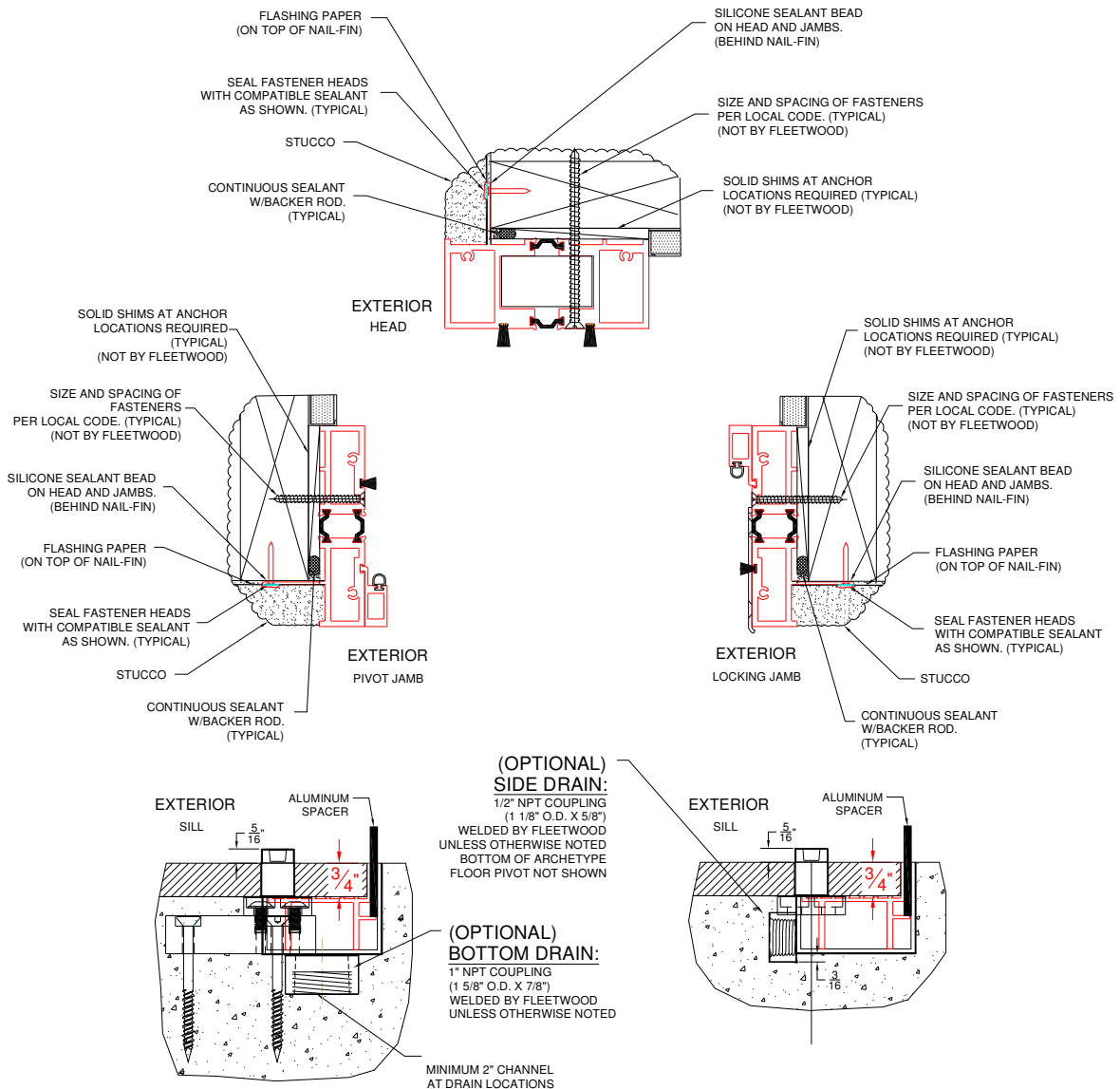
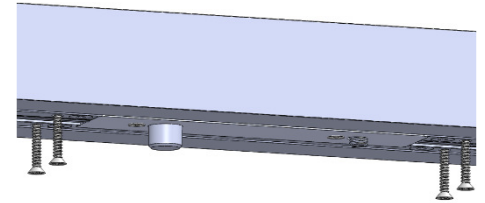

**Figure 7:**  
IRC Nail-fin frame installation

**VIII. Block Frame Installation**

**Note:** Fleetwood recommends the use of a laser level or 8' level for frame installations. Cross-measure, tolerance is within  $\pm 1/32"$  for interior and exterior.

1. Seal frame and vent joints completely with compatible sealant.
2. Insert the frame into the Arche-Duct. Cross-measure and adjust to achieve a plumb square and level condition. Shim where needed. Seal all fastener heads with compatible sealant.
3. Secure Archetype Head Pivot to header with #10 screw min. 4" long (not by Fleetwood). See Figure 8 for illustration.
4. Archetype Floor Pivot installation see Section IX.



**Figure 8:**  
Securing Archetype Head Pivot  
(Block Frame Shown)

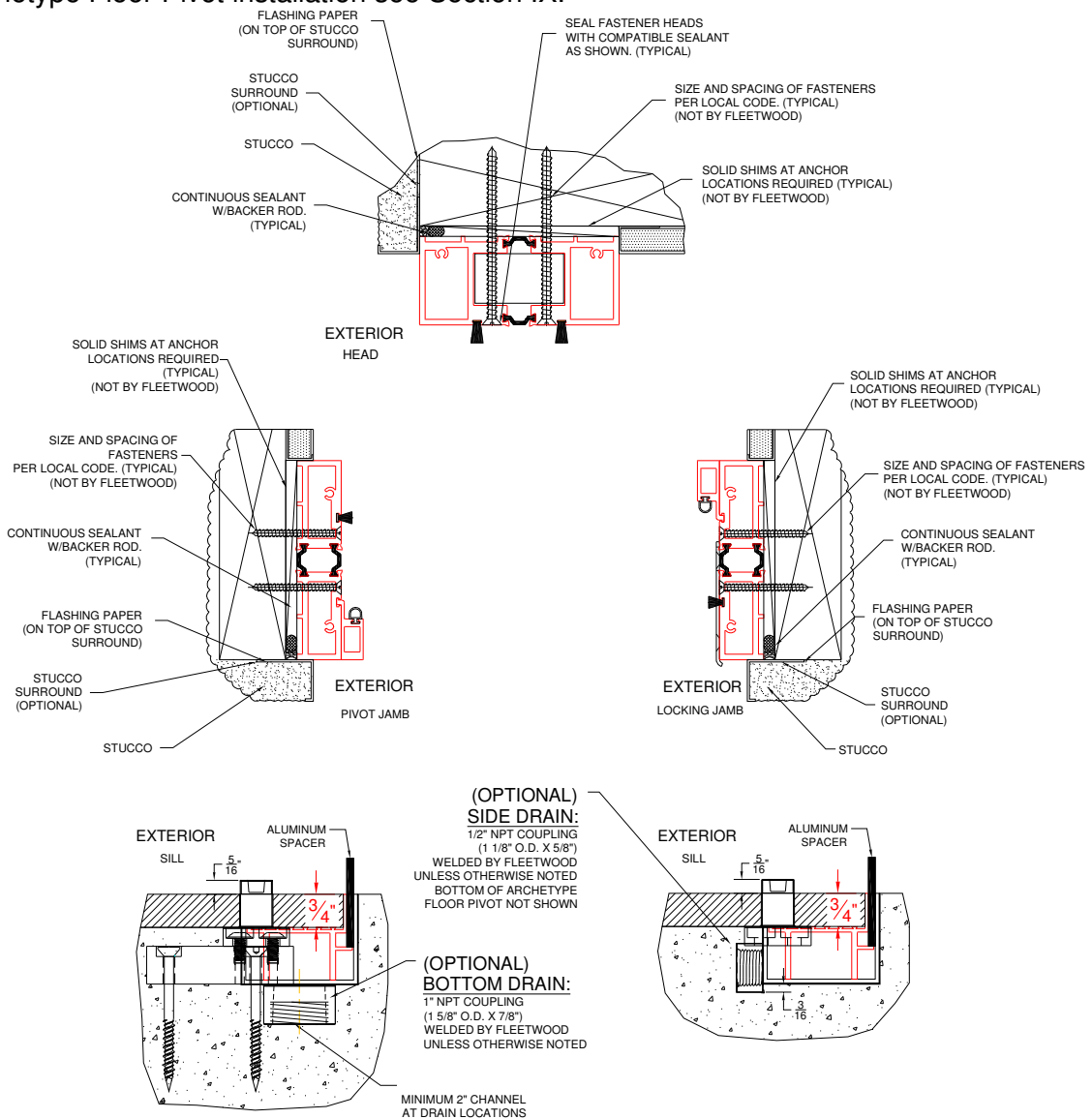

**Figure 9:**  
IRC Block Frame Installation

**IX. Archetype Floor Pivot (AFP) Installation**

**CAUTION:** Review flooring structural specifications prior to installation.

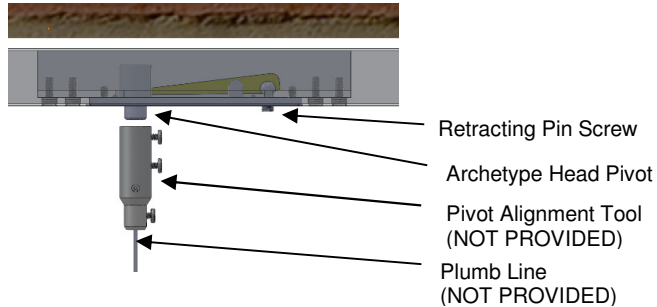

**Figure 9:**  
In-line Verification

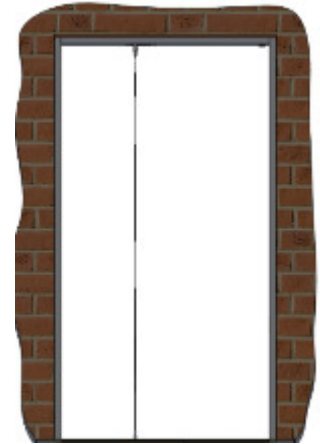

1. Positioning the AFP into blocked out area.
  - a. Use a plumb line to center the Archetype Floor Pivot location with the Archetype Head Pivot pin (Figure 9).
  - b. Assembled Archetype Floor Pivot (red bag attached to frame) to sit  $5/16$ " above finished floor, backfill after installation (Figure 2).
  - c. The provided center location hole on the bottom section of the Archetype Floor Pivot is to be set back  $2-1/16$ " from the interior face of the jamb and level (Figure 10).

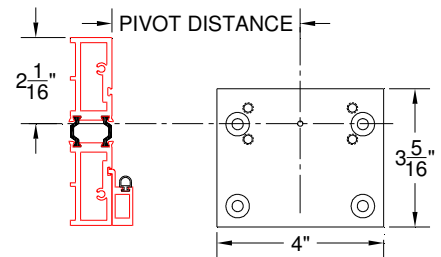

Exterior  
**Figure 10:**  
Archetype Floor Pivot Positioning

2. Anchoring the AFP
  - a. Use a plumb line to center the Archetype Floor Pivot with the Archetype Head Pivot. Mark the anchor hole locations of the Archetype Floor Pivot.
  - b. Remove the Archetype Floor Pivot. If using the factory provided concrete screws, drill  $2-1/2$ " deep (for concrete use a  $3/16$ " dia. bit). Clean away excess debris.
  - c. Fasten to the floor (Figure 11), the bottom section of the Archetype Floor Pivot with the factory provided concrete anchor screws ( $1/4$ " FHP Concrete screw,  $3-1/4$ ").
3. Assemble the top section of the Archetype Floor Pivot using a  $5/32$ " hex key (Figure 12). Verify and adjust the position of the Archetype Floor Pivot as necessary (Figure 13), retighten.
4. Note: Backfill Archetype Floor Pivot after panel and glazing installation / adjustments are performed.

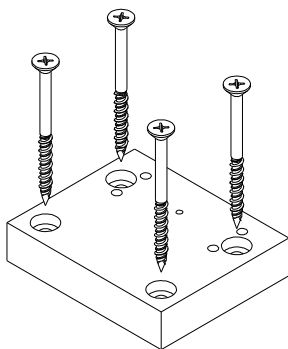

**Figure 11:**  
Securing the Archetype Floor Pivot

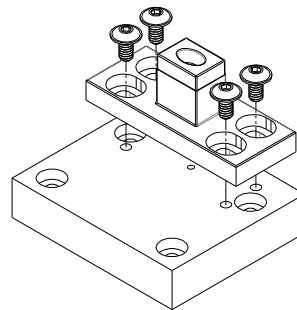

**Figure 12:**  
Archetype Floor Pivot Assembly

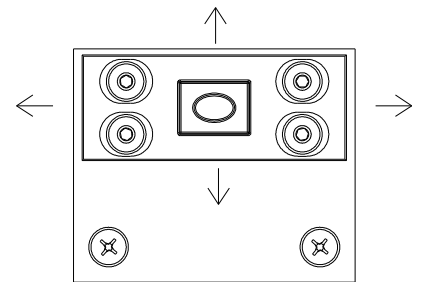
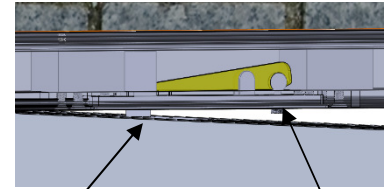

**Figure 13:**  
Radial Adjustment

## X. Panel Installation

- **Handle Pull Installation** see Appendix A.
- **Closing Speed Adjustment** see Appendix B.

1. Retract Archetype Head Pivot pin by turning retracting pin screw counter clockwise (Figure 14).
2. Ensure the closer is orientated correctly for installation with the Archetype Floor Pivot, the arrow should point to the closing side of the door (Figure 15). If needed, remove floor closer from bottom rail and use Archetype Floor Pivot (installed or with leverage) to orientate correctly.



Archetype Head Pivot Retracting Pin

**Figure 14:**  
Archetype Head Pivot Locking

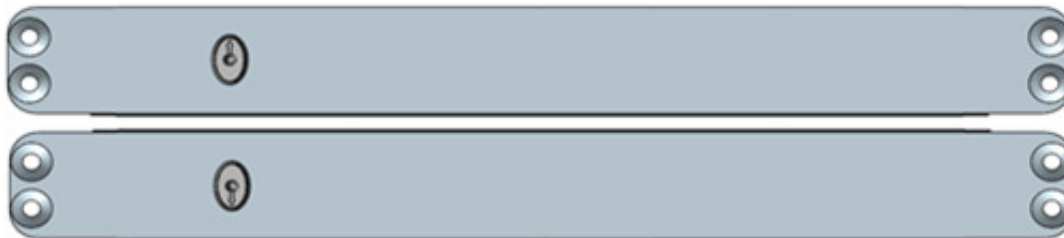

**CORRECT**  
Pivot Right Outswing  
Pivot Left Inswing

**CORRECT**  
Pivot Right Inswing  
Pivot Left Outswing

**Figure 15:**  
Closer Orientation (Bottom View Shown)

**CAUTION:** Do not apply any pressure on the glass stop side of the bottom rail.

3. Place the panel perpendicular to the frame and lift into the opening.
4. Align panel closer with Archetype Floor Pivot and lower.
5. Align the two portions of the Archetype Head Pivot and turn the retracting pin screw clockwise (Figure 14).
6. To complete the panel installation, apply backer rod and a complete bed of sealant to the entire exterior and interior joint between the frame and the building structure. Tool the sealant to eliminate bubbles, voids and / or breaks and ensure a completely watertight seal (Figure 7,9).
7. Note: Backfill Archetype Floor Pivot after panel and glazing installation / adjustments are performed.

## XI. Finished Flooring Installation

**Flooring Material:** The sill for this product was designed to incorporate the finished flooring as a key component to the bottom rail sealing and the linear slot drain. The material chosen to surround the extruded sill should be such that water will not damage it.

**Linear Slot drain:** The sill comes with an aluminum spacer to ensure the linear slot drain spacing is correct. This spacer is to be removed after the flooring is installed.

## XII. Flashing after Installation

The flashing paper referred to in this document is Moistop or other code compliant flashing material that conforms to **Federal Specification UU-B-790a, Type 1, Grade A, Style 4**. The strips of flashing paper are to be no less than 9 inches wide (or wider as required by local codes). Flashing paper must be applied with galvanized nails or corrosion resistant staples. Flashing paper shall be applied in a weatherboard fashion around the full perimeter of the framed opening.

1. Once satisfied that the frame is water tight, and immediately prior to application of the flashing paper at the head and jambs, apply a continuous bead of sealant to the exposed mounting flange (nail-fin) at the top (head) and sides (jambs) of the installed frame. Also, apply sealant at corners of the frame, the full length of the seams where the nail fin flashing is mounted.
2. At each jamb, embed the flashing paper into the sealant onto mounting flange and fasten into place. The flashing paper should be cut sufficiently long enough to extend at least 3" past the weep-screed or diado flashing and at least 6 inches above the head of the window (Figure 16).
3. Finally, at the head, embed the flashing into the sealant on the mounting flange and fasten into place. The flashing paper should be cut sufficiently long enough to extend past the flashing paper at each jamb by at least 3" (Figure 17).
4. Weather resistant building paper should be applied in a weatherboard fashion to complete the installation (Figure 18).

**Note:** Where weather resistant building paper, insulating board, or other materials by other trades may constitute the primary weather barrier behind the exterior wall finish (i.e. stucco, masonry, siding, etc.), the owner / General Contractor are responsible to ensure that the weather barrier is continuous by effectively sealing the material to the window frame.

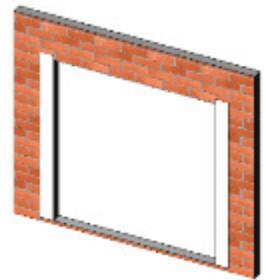

**Figure 16:**  
Jamb flashing

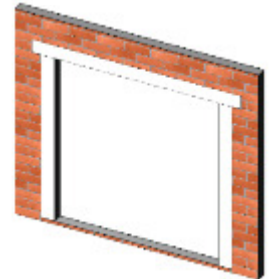

**Figure 17:**  
Head Flashing

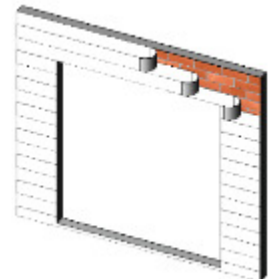
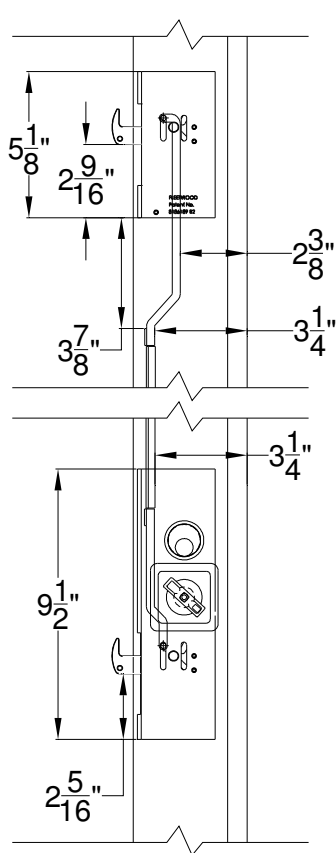

**Figure 18:**  
Building Flashing

**Appendix A: Hardware Locations**

The following are latching hardware locations to avoid when installing **surface mount handle pulls**.

**Note:** After any holes are drilled into the product, a small amount of silicone should be applied to the exposed surfaces.



**Figure A1:**  
 Archetype Latch and Secondary Latch

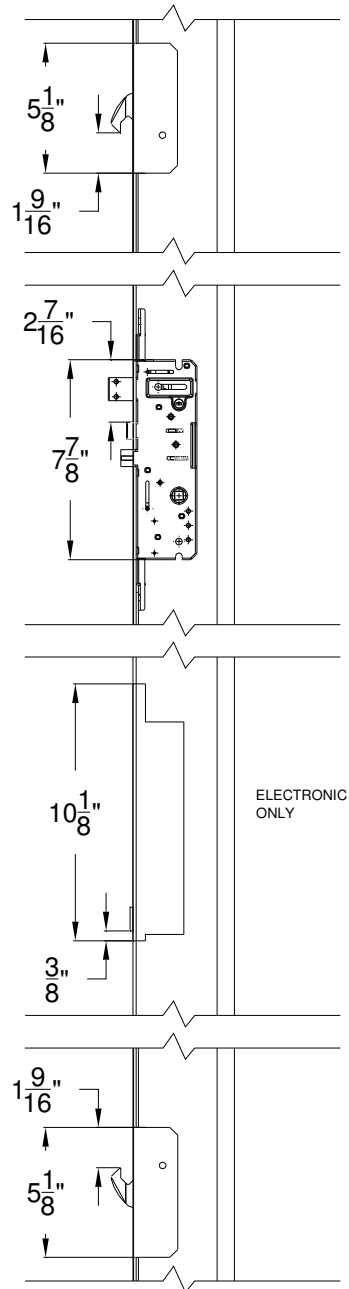

**Figure A2:**  
 5 Point Latch / Electronic Latch

**Appendix B: Adjusting Closer Speed**

To adjust the closer speed, use the (5mm) open ended wrench provided with the AFP. In some cases, removal of the panel may be necessary. See images below for more details. Clockwise will reduce the closing speed. Counter-Clockwise will increase the closing speed.

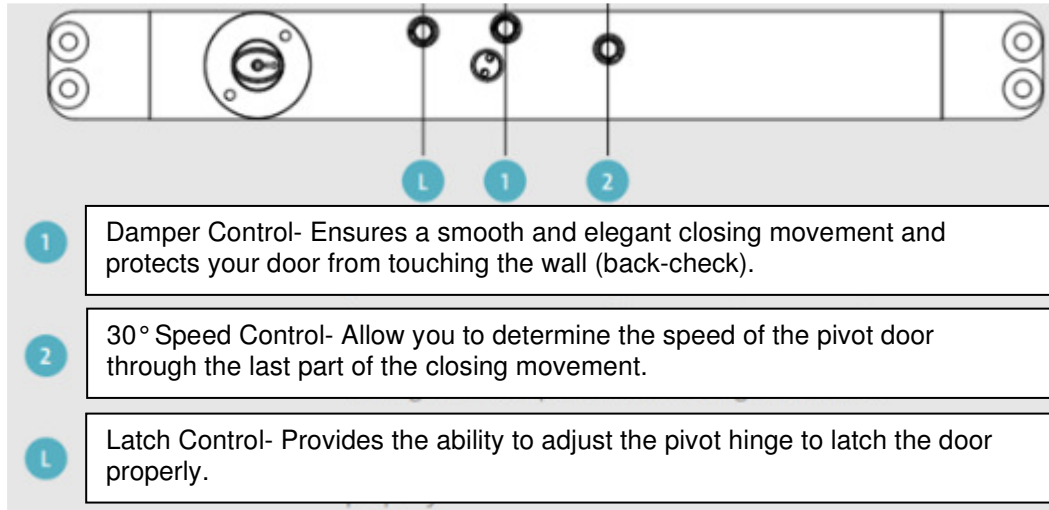

**DAMPER CONTROL**

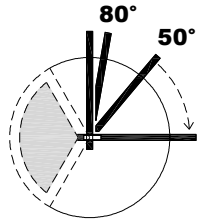

Damper Control has two functions. The hydraulic back-check protects the pivot door against touching the wall by providing adjustable resistance as the approaches the 80° position. The closing damping makes the door close smoothly.

**30° SPEED CONTROL**

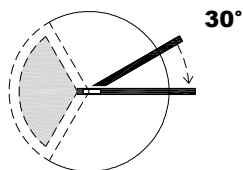

30° Speed Control allows you to fine-tune the speed of the pivot door through the last 30° of the closing movement.

**LATCH CONTROL**

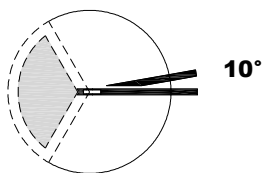

Latch Control provides the ability to adjust the closing speed to latch the door properly. Latch Control enables the door to accelerate in the last 10° to ensure proper latching of the door.

**Figure B1:**  
Closer Adjustment Illustrations

**Appendix C: Archetype Floor Pivot – Remodel (AFP-R)**

1. The AFP-R requires a flooring block out.

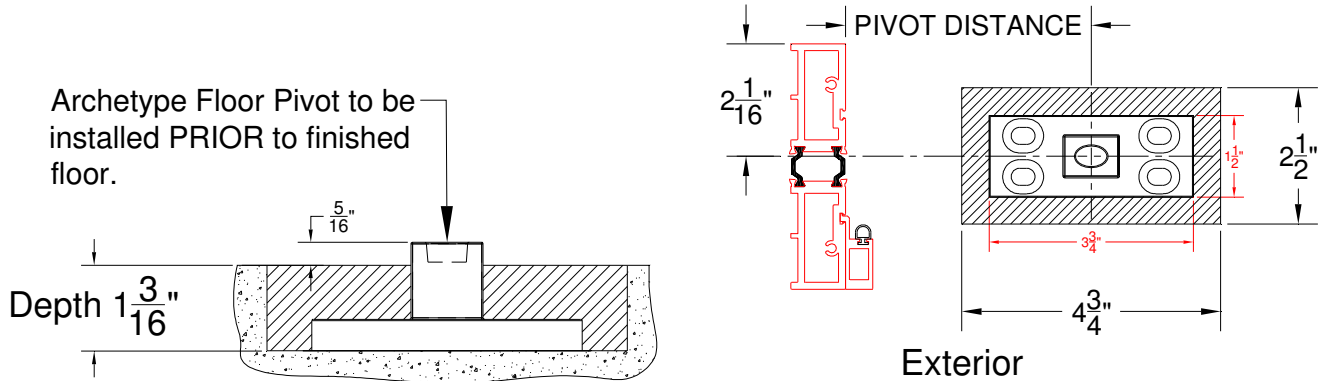

**Figure C1:**  
AFP-R Block Out and Positioning

2. Positioning the AFP-R into blocked out area.
  - a. Use a plumb line to center the AFP-R location with the Archetype Head Pivot pin. AFP-R to be parallel with frame.
  - b. Top of AFP-R (red bag attached to frame) to sit 5/16" above finished floor, backfill after installation (Figure C1).
  - c. The center of the AFP-R is to be 2-1/16" from the interior face of the jamb and level (Figure C1).
3. Anchoring the AFP-R
  - a. Use a plumb line to center the AFP-R with the Archetype Head Pivot. Mark the anchor hole locations.
  - b. Remove the AFP-R. Drill into substrate. Clean away excess debris.
  - c. Fasten the AFP-R into the substrate.
  - d. Verify and adjust the position of the AFP-R as necessary.
4. Note: Backfill AFP-R after panel and glazing installation / adjustments are performed.