

Table of Contents

I. Care and Maintenance 2

II. Tools / Materials, Sealant Requirements, & Anchor Instructions 2

III. Assembly and Installation 2

IV. Structure Verification 3

 1. Opening Verification 3

 2. Pre-Fit and Leveling 3

 3. Flash the Opening 3

 4. Sillpan Installation 4

V. Frame Assembly (When frame is received unassembled) 4

VI. Frame Installation 5

 Nail-fin Frames 5

 Block Frames 7

VII. Glazing Instructions per Glass (block frame shown) 9

 Dry Glazing Procedure 9

 Additional Glazing Procedure 9

VIII. Flashing after Installation 10

Appendix A: Joining Sillpans 11

Appendix B: Stucco Surround Application (Optional) 12

Appendix C: Product Inserts 13

Appendix D: CLiC Glass Installation 14

I. Care and Maintenance.

This product is factory finished. Please handle with extreme care. Protect all exposed surfaces from contact with caustics, corrosives, solvents, abrasions, impacts, wet packing material etc.

FAILURE TO DO SO WILL NULLIFY THE WARRANTY. Before **ANY CLEANING**, review the Care & Maintenance Instructions (go to www.fleetwoodusa.com for more information). **Contact the local dealer with any questions or concerns.** Fleetwood strongly recommends that all products be cleaned after installation and totally protected from construction debris and equipment.

II. Tools / Materials, Sealant Requirements, & Anchor Instructions

Tool Requirements: Tape measure, Level, Shims, Nails, Screws, Sealant, caulk gun, Backer Rod, Scissors or utility knife, hammer, putty knife, drill bit, drive bit and powered drill.

Sealant Requirements

- The sealant referred to within this document for seals associated with the assembly of the product should conform to **AAMA 800**. It is recommended that all other sealants should also conform to **AAMA 800** but may be a sealant recommended and approved by the sealant manufacturer that is compatible with the framing, finish and surrounding materials.
- All sealant bead sizes must conform to the sealant manufacturers' size requirements.
- The Owner / General Contractor is responsible for identifying the need for any additional sealant to be applied by others. Such sealant shall be elastomeric material, with the framing, finish and surrounding materials.

Anchor Instructions

- Structural engineer to determine anchor quantity and spacing for design load requirements.
- Proper material must be used between all dissimilar materials (i.e. block/concrete & aluminum).

Extreme Weather Conditions (Thermally Broken Product Only)

1. For installations that will be exposed to extreme weather, apply a compatible sealant on top of the thermal break cavity of all sills, t-bars and stack bars (Figure 1).
2. The provided sillpan is to ensure that any incidental water that penetrates the thermal break or mulled connection is collected and directed to the exterior of the building. In extreme weather, replace or cover the aluminum sill pan with nonconductive material to prevent frost or condensation from reaching the building interior.

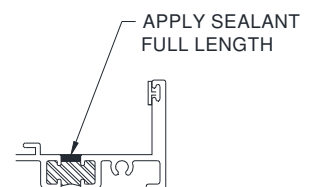

Figure 1:
Seal Thermal Break

III. Assembly and Installation

It is essential that each Fleetwood product be assembled and glazed in accordance with AAMA standards and factory instructions. It is the installer's responsibility to ensure that each Fleetwood product is assembled, glazed and installed and completely sealed to ensure that the product is leak-free and operates correctly. **Installation of Fleetwood products must be in accordance with the standards set forth in ASTM E 2112.** If there are any questions regarding the installation of a Fleetwood product contact the factory customer service department.

Due to inherent manufacturing tolerances Fleetwood has provided this product with recommended field glazed weather-stripping. If the provided weather-stripping does not ensure an optimum fit of glass to frame the Fleetwood Authorized Dealer should contact Customer Service for an expedited **NO CHARGE** shipment of replacement weather-stripping.

IV. Structure Verification

Note: Sillpan Substitution- If the factory provided sillpan is not desired, the product warranty will remain intact if the substitute panning system emulates the essential design of the factory pan.

1. Opening Verification

- Check the measurements of the opening and verify that the door will fit into the opening. Measure all four sides of the opening to make sure it is 1/2" larger than the product in width and 1/2" in height.
- Verify the opening is plumb and level.
- Remove the product from the packaging and lay it in front of the opening. Check width and height dimensions.

2. Pre-Fit and Leveling

- Place sillpan into the opening and determine any leveling that must be done prior to installation (Figure 2).
- Shim as necessary to stabilize the entire depth and length of the sillpan. No unsupported width of more than 8" is allowed. Shim(s) should be load bearing, non-porous, non-absorbent and inorganic.
- If more than 1/8" shim height is required, it is recommended to use a self-leveling product like "Rock Hard" (or equal) to achieve a level and stable surface.

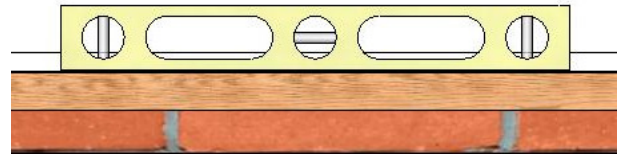
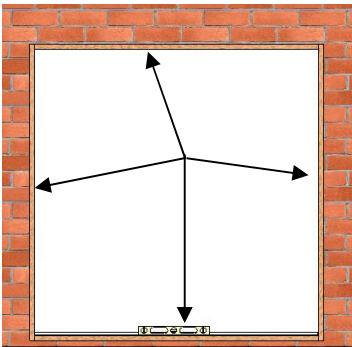

Figure 2:
Use level to determine if the opening is plumb and level

3. Flash the Opening

- Once the opening has been confirmed, flashing of the opening is required prior to Frame installation. Paper and/or liquid flashing methods are acceptable (see AAMA 711/714 for material requirements).
- Check local Building codes for any additional flashing requirements.

Paper Flashing

- At the Sill and each Jamb, the flashing paper should be cut at least 3" past the weep-screed or diado flashing and at least 6" above the head of the door. The flashing must wrap around at least 3" back into the opening.
- At the Head, run the flashing paper long enough to extend at least 3" past the jamb flashing and wrap around the Header at least 3" into the opening.

Liquid Flashing

- Follow the liquid flashing manufacturer instructions.

4. Sillpan Installation

Note: For splicing and multiple piece Sillpans see Appendix A.

- The provided sillpan is to ensure that any incidental water that penetrates the thermal break or muller connection is collected and directed to the exterior of the building.
- Apply bituminous paint to raw masonry or concrete at the sill to eliminate electrolytic and chemical reactions. It is recommended a PVC liner be placed to ensure separation of the metal frame with the substrate. In balcony situations flash the sill with aluminum or galvanized brake metal (Sillpan is provided).
- Apply sealant in all corners and seams of the sill pan (Figure 3).
- With bottom side of sillpan up, apply a 3/8" bead of compatible sealant 1/2" in from interior leg. Sealant bead to run across the bottom as well as up each vertical leg of the sill pan. Also apply sealant beads near the sides and across the front (Figure 4).
- Secure the sillpan to the floor with glue. Position sill pan as necessary to allow for proper installation of frame assembly (Figure 5).

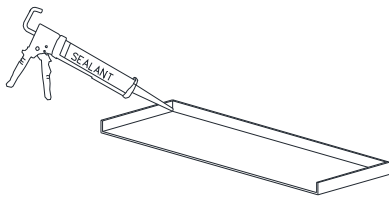

Figure 3:
Seal corners and seams

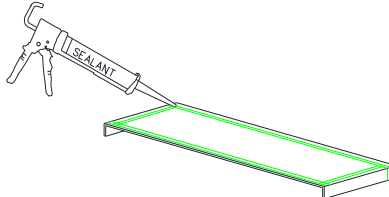

Figure 4:
Seal underside of Sillpan

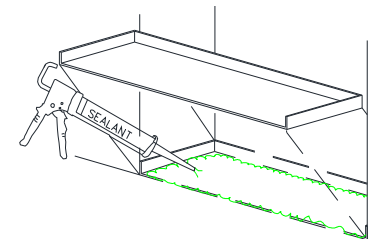

Figure 5:
Set pan in full bed of sealant

V. Frame Assembly (When frame is received unassembled).

Important Note: Glass stops must be field cut to size after the frame is assembled. Failure to assemble the frame according to the installation instructions, nullifies warranties related to this product.

1. Apply a compatible sealant to the corners of the frame. Assemble the frame with screws provided (Figure 6).
2. Install Jambs to Head and Sill using #10 X 1" PHP (provided)
3. Locate glass stops and cut to size once frame is assembled.
4. After the frame is assembled, seal inside of all four corners, joints and above the thermal break (Figure 10) with a thin attractive bead of self leveling compatible sealant
5. Field cut glass stops to fit.

Non-intersecting TDL bars

1. Install each full length (vertical or horizontal) TDL bar, using #10 X 1" PHP into pre-drilled holes (Figure 6).

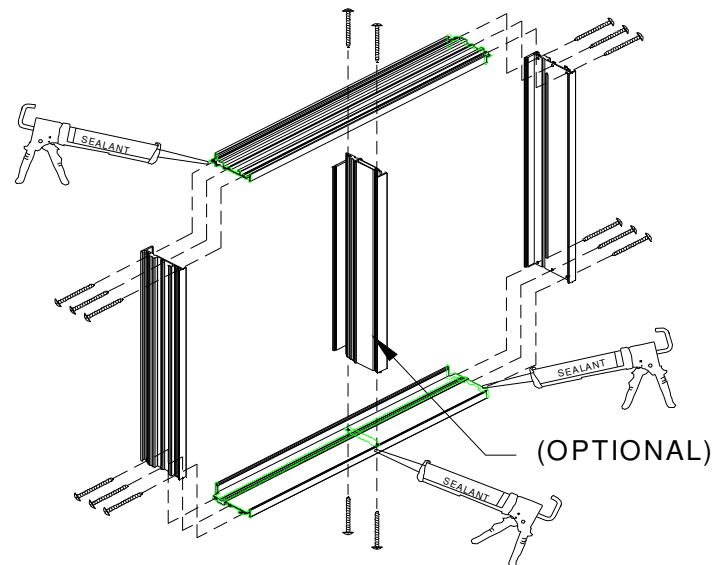

Figure 6:
Assemble Frames and Sealant

Intersecting TDL Bars, Non-Impact / not HVHZ

Important Note: All bolts, nuts, and L braces are provided in a plastic bag.

1. Install each full length (vertical or horizontal) TDL bar, using #10 X 1" PHP into pre-drilled holes (Figure 6).
2. Install each partial length (vertical or horizontal) TDL bar, using #10 X 1" PHP into pre-drilled holes.
3. Install L Braces into the intersecting TDL bars using the provided Hex bolt and Lock nuts (sizes 1/4" and 3/8" respectively) into the pre-drilled holes and tighten down (Figure 7).
4. Apply a compatible sealant to the slot, screw heads, and TDL ends.

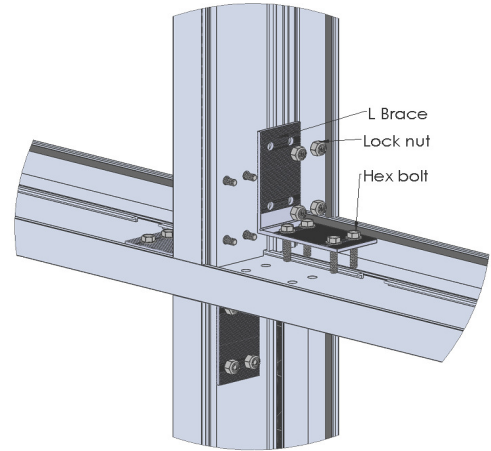

Figure 7:
Frames with Multiple TDL Bars
(Aluminum insert not shown)

Note: Do not cover weep holes on TDL with sealant.

5. Fasten top & bottom frames to vertical TDL.
6. Fasten side frames to horizontal TDL.
7. Cut glass stops to fit.

VI. Frame Installation

Important Note: For Impact / HVHZ- See applicable *Installation Instructions* for anchor schedule with different substrates.

Nail-fin Frames

1. Prepare the opening to accept the frame ensuring that the weep-screed or diado flashing at the sill is adjusted to maintain a weatherboard style flashing.
2. Flashing paper must be applied with galvanized nails or corrosion resistant staples. Flashing paper shall be applied in a weatherboard fashion around the full perimeter of the framed opening.
3. Seal frame and vent joints completely with compatible sealant.

IMPORTANT: Apply a heavy bead of sealant to the interior side of the mounting flange (nail-on) where the frame jamb and sill join. Sealant must cover the entire joint (from the flange to the inside leg) and extend 1 1/2" up the jamb and along the sill (Figure 9).

4. Insert the frame into the opening and set the sill in a full bed of sealant (Figure 10). Cross-measure and adjust as necessary to achieve a plumb square and level condition, as well as an even reveal around the framed opening. Shim with non-porous, non-absorbent, inorganic shims where needed. Seal all fastener heads with compatible sealant. (Only drill holes through Sill as required for design load)
5. Anchor Location and Sealant.
Frame installation anchors furnished by installer, not by Fleetwood. Stainless steel screws are recommended.

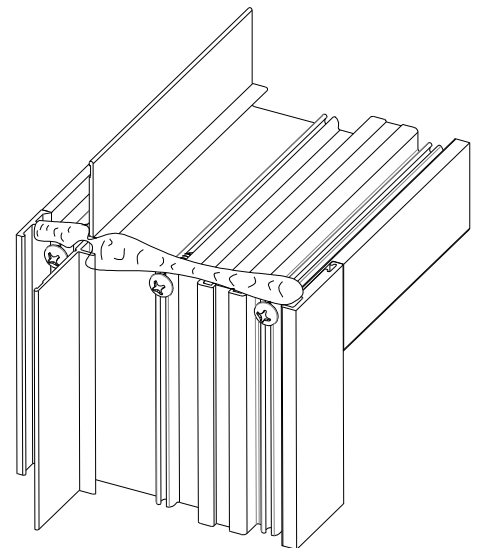

Figure 9:
Nail-fin sealant location

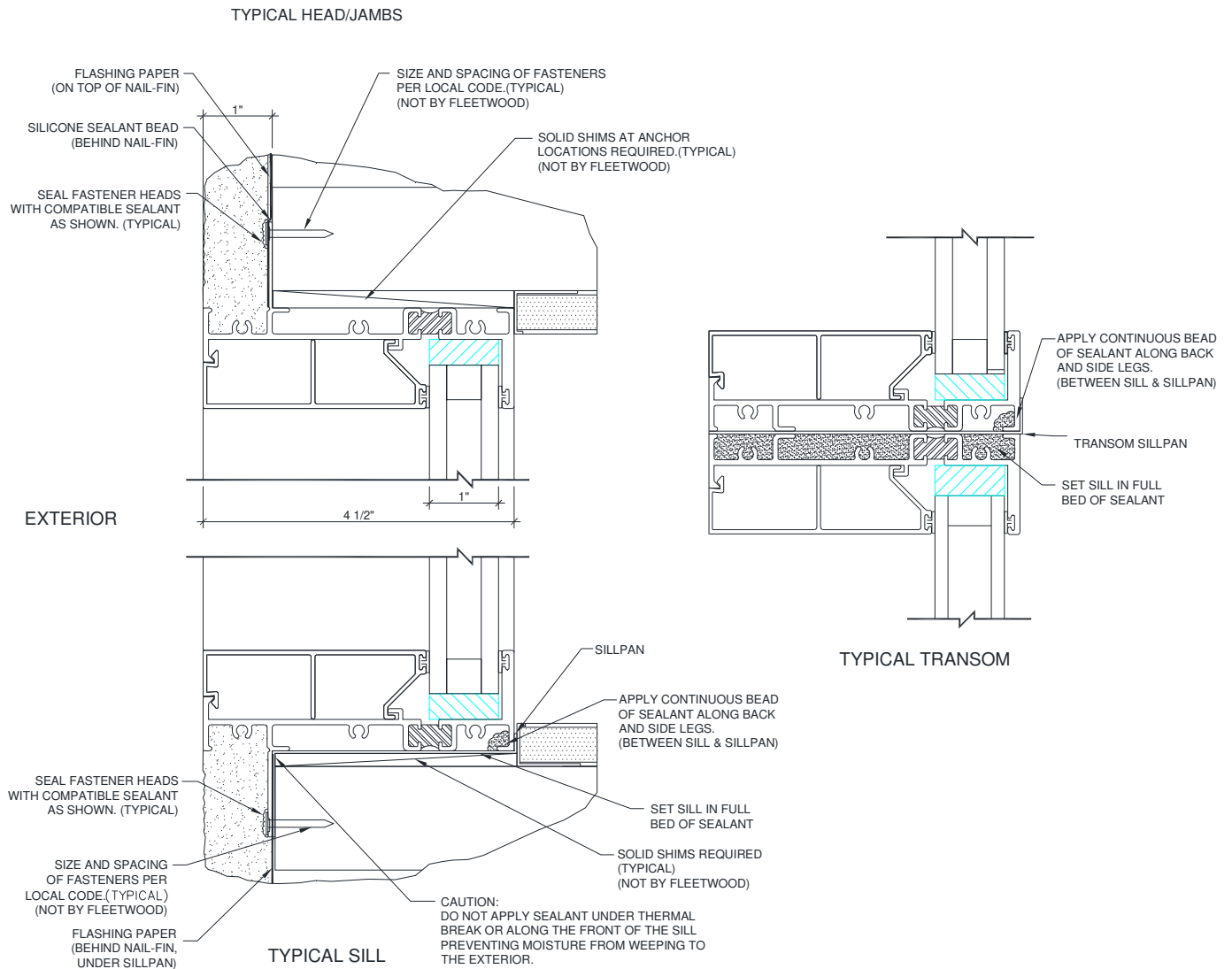

Figure 10:
Typical Nail-fin with Sealant Shown (Exterior Glazed)

Block Frames

Important Note: For Impact / HVHZ- See applicable *Installation Instructions* for anchor schedule with different substrates.

Note: For optional stucco surround application see Appendix B.

1. Prepare the opening to accept the frame ensuring that the weep-screed or diado flashing at the sill is adjusted to maintain a weatherboard style flashing.
2. Seal frame and vent joints completely with compatible sealant.
IMPORTANT: Apply a heavy bead of sealant where the frame jamb and sill join. Sealant must cover the entire joint (Figure 11).
3. Insert the frame into the opening and set the sill in a full bed of sealant (Figure 12). Cross-measure and adjust as necessary to achieve a plumb square and level condition, as well as an even reveal around the framed opening. Shim with non-porous, non-absorbent, inorganic shims where needed. Seal all fastener heads with compatible sealant. Only drill holes through Sill as required for design load.
4. Anchor Location and Sealant
Frame installation anchors furnished by installer, not by Fleetwood. Stainless steel screws are recommended. Fleetwood recommend countersink for all frame anchors.
5. The installer is responsible for the integrity of all framing joints after installation and **must water test all joints** to guarantee a completely sealed product. Apply joint sealer and/or sealant necessary to ensure watertight joints. Retest as necessary.
6. To complete the installation, apply backer rod and a complete bead of sealant to the entire exterior and interior joint between the frame and the building structure. Tool the sealant to eliminate bubbles, voids and / or breaks and ensure a completely watertight seal (Figure 12).

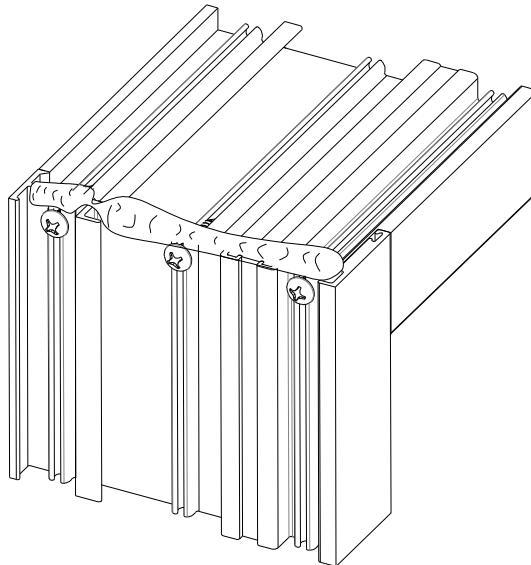
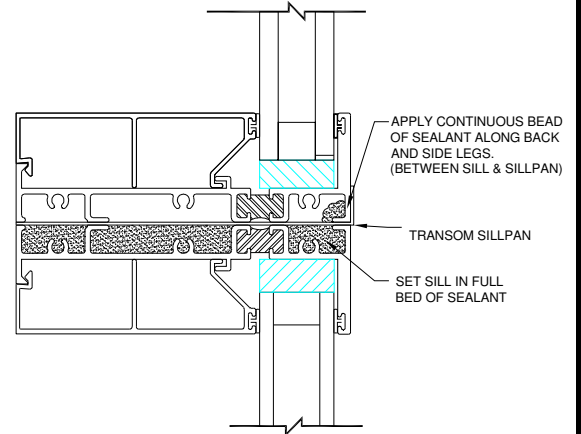
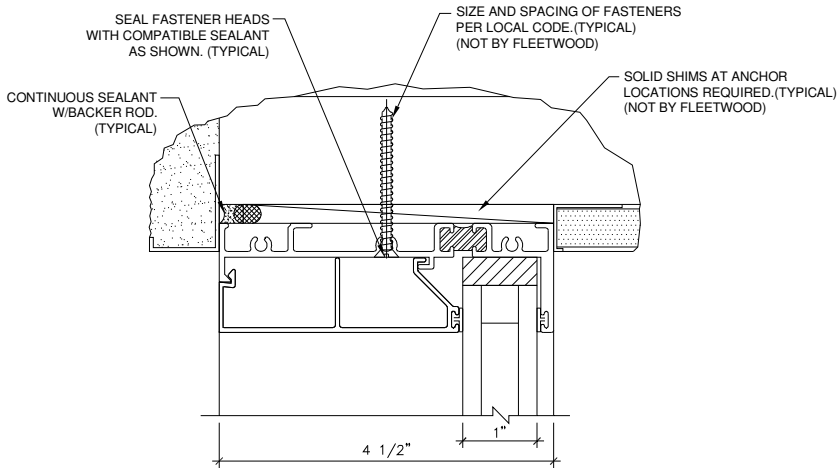

Figure 11:
Block frame sealant location

TYPICAL HEAD / JAMBS



TYPICAL TRANSOM

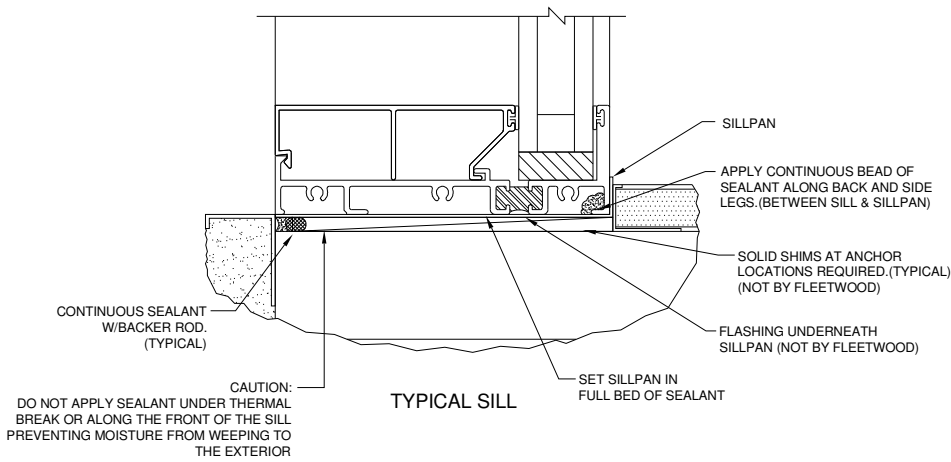

Figure 12:
 Standard Sill with Sealant Shown (Exterior Glazed)

VII. Glazing Instructions per Glass (block frame shown)

Note: Glass stops must be removed before continuing. If tiered glass stops were chosen, see appendix C for fabrication details.

Dry Glazing Procedure

1. Insert two setting blocks into the sill at the quarter points (Figure 13).
2. Insert glass setting block per jamb at 2" above the sill.
3. All four corners must be sealed 1/2" x 1/2" x 4" (Figure 14) then set glass into opening.
4. Insert edge blocks into each jamb at 2" above the sill and into the head at glazing center (Figure 13).
5. Finish assembly by inserting the two horizontal glass stops then install the two vertical glass stops.

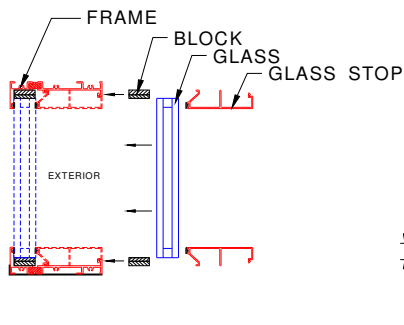

Figure 13:
Setting Block Locations

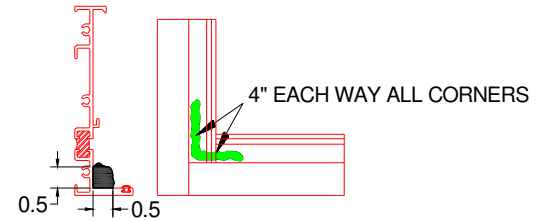
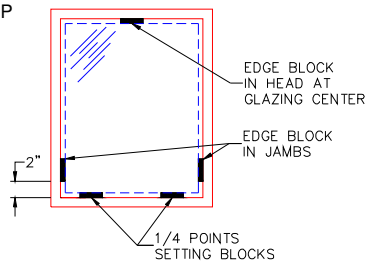

Figure 14:
Sealant Location and Sizes

Additional Glazing Procedure

Note: Applies to inside glazed or outside glazed products where additional water protection is required.

1. Before glazing, apply a continuous bead of sealant to the inner flange (Figure 15).
2. After glazing, apply a continuous bead of sealant to the outer edge of the flange (Figure 16).

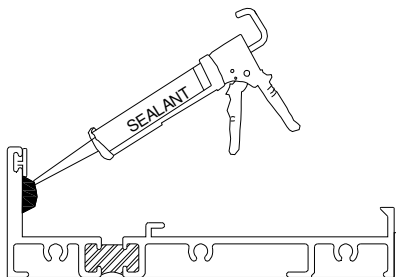

Figure 15:
Before Glazing Locations

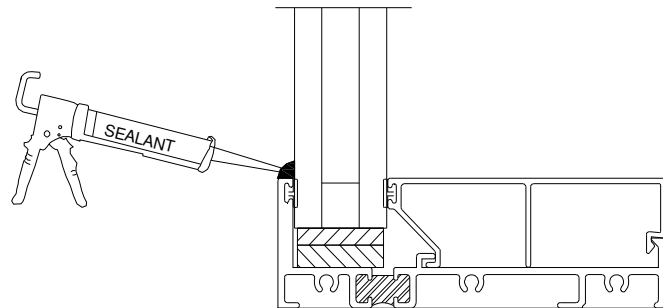

Figure 16:
After Glazing Locations

VIII. Flashing after Installation

The flashing paper referred to in this document is Moistop or other code compliant flashing material that conforms to **Federal Specification UU-B-790a, Type 1, Grade A, Style 4**. The strips of flashing paper are to be no less than 9 inches wide (or wider as required by local codes). Flashing paper must be applied with galvanized nails or corrosion resistant staples. Flashing paper shall be applied in a weatherboard fashion around the full perimeter of the framed opening.

1. Once satisfied that the frame is water tight, and immediately prior to application of the flashing paper at the head and jambs, apply a continuous bead of sealant to the exposed mounting flange (nail-fin) at the top (head) and sides (jambs) of the installed frame. Also, apply sealant at corners of the frame, the full length of the seams where the nail fin flashing is mounted.
2. At each jamb, embed the flashing paper into the sealant onto mounting flange and fasten into place. The flashing paper should be cut sufficiently long enough to extend at least 3 inches past the weep-screed or diado flashing and at least 6 inches above the head of the window (Figure 17).
3. Finally, at the head, embed the flashing into the sealant on the mounting flange and fasten into place. The flashing paper should be cut sufficiently long enough to extend past the flashing paper at each jamb by at least 3 inches (Figure 18).
4. Weather resistant building paper should be applied in a weatherboard fashion to complete the installation (Figure 19).

Note: Where weather resistant building paper, insulating board, or other materials by other trades may constitute the primary weather barrier behind the exterior wall finish (i.e., stucco, masonry, siding, etc.), the owner / General Contractor are responsible to ensure that the weather barrier is continuous by effectively sealing the material to the window.

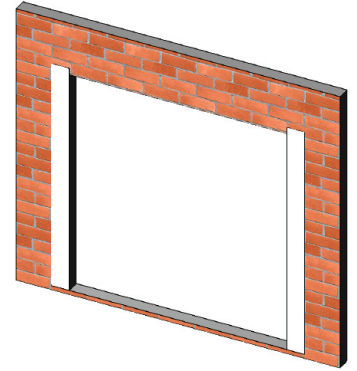

Figure 17:
Jamb Flashing

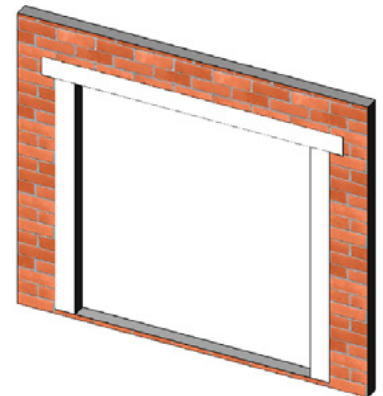

Figure 18:
Head Flashing

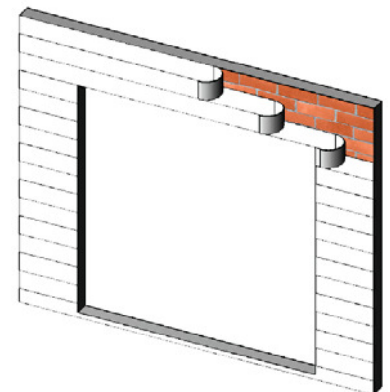

Figure 19:
Building Flashing

Appendix A: Joining Sillpans

Follow the instructions below for joining multiple piece Sillpans. Multiple piece Sillpans are required on products with net frame widths greater than 14 feet (168 inches) and corner units.

1. Install Sillpans per product installation instructions. Apply a compatible sealant to the underside of the sillpan at the seam joint.
2. Cut a piece of adhesive backed waterproof material to fit the joint as specified in drawing below, A= 3/8".

Caution: Select waterproofing material that is compatible for your application. Waterproofing material must have an adhesive backing and be capable of withstanding the temperature ranges for your region.

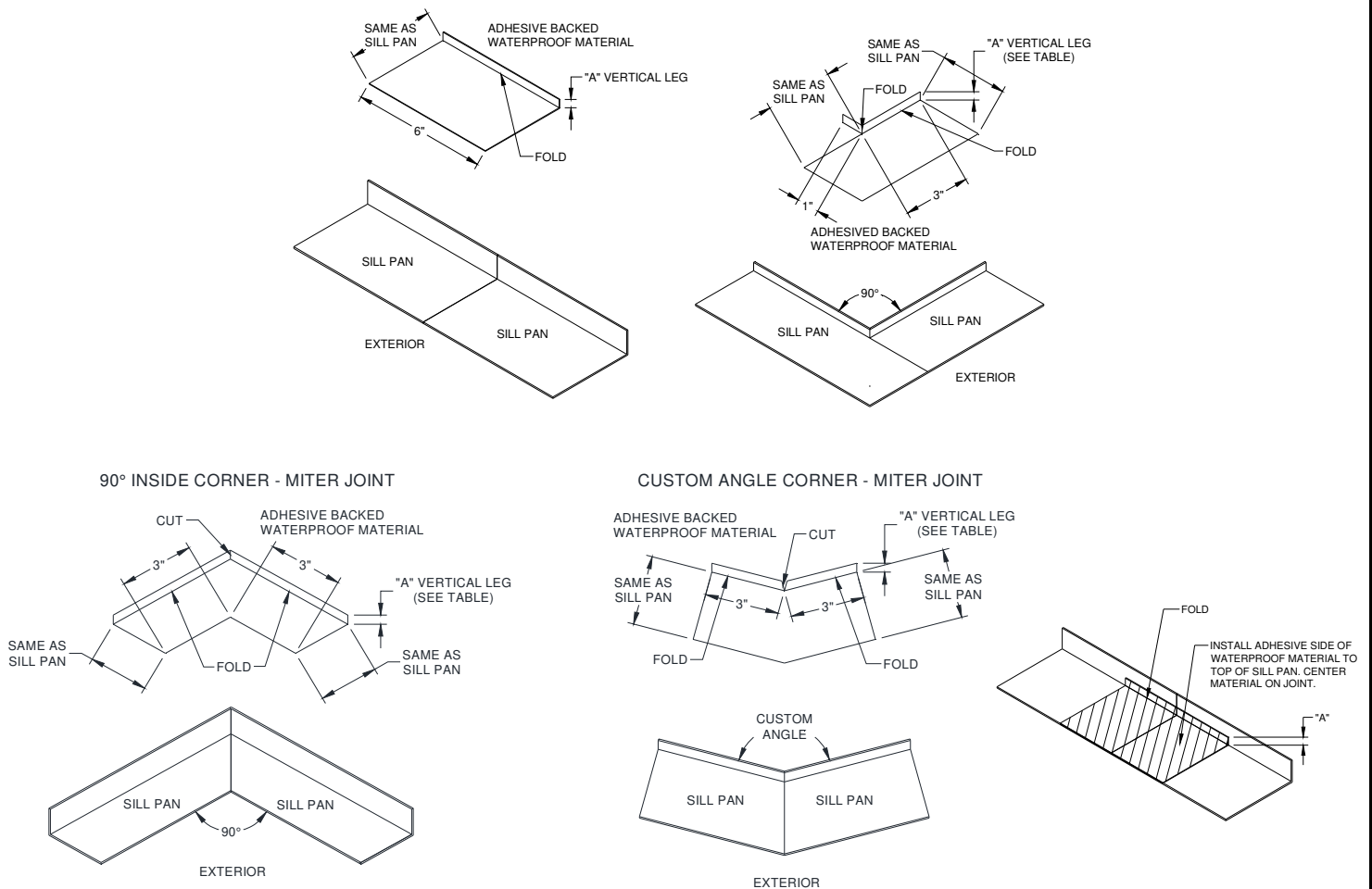

Figure A1:
Showing multiple piece sill pans joining

3. Remove excess sealant at joint on top of the sillpan that may have migrated in during installation.
4. Expose the adhesive backing from the waterproof material and apply to the sillpan. Waterproof material shall contain a fold on the interior water leg and attach to the sillpan as shown.

Appendix B: Stucco Surround Application (Optional)

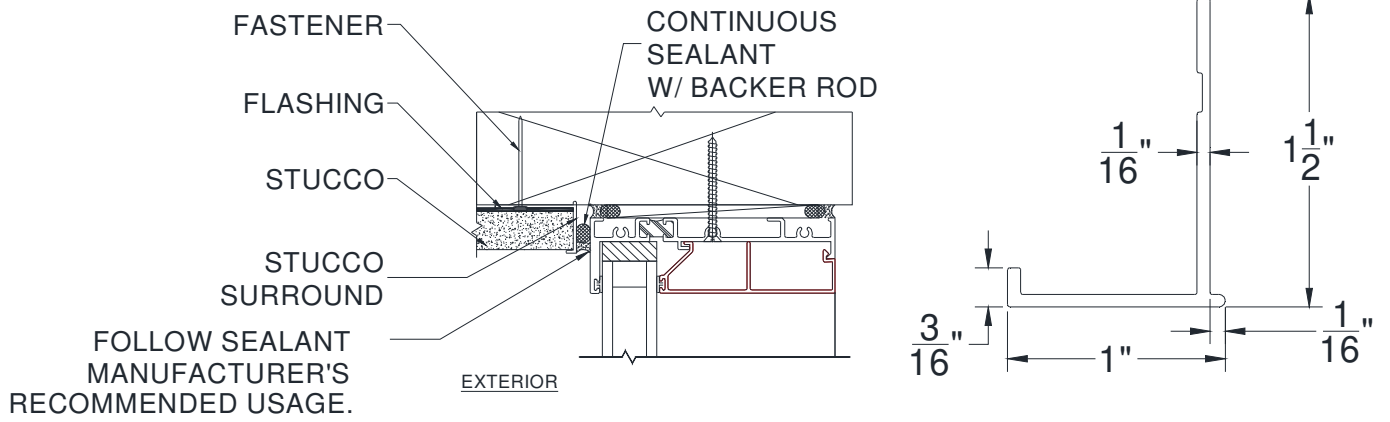

Figure B1:
 Stucco Surround Detail and Extrusion

Appendix C: Product Inserts

Note: Install Series 3800-T frame into opening before inserting other products.

Setting block requirements

- a. Series 350-T Projected Windows
w/ 4-Bar Hinges- two 1/4"×1"×4" setting blocks
w/ Butt Hinges- two 3/8"×1"×4" setting blocks
 - b. Series 450-T Projected Window
two 1/4"×1"×4" setting blocks
 - c. Doors
Sill- one 1/4"×1"×4" setting blocks
Jambs- two 1/4"×1"×4" setting blocks
1. When 2 blocks are required, bond Setting Blocks together with a compatible sealant (Figure C1).
 2. Locate the setting blocks at 7 1/2" from each end and one in the center. Apply sealant to the underside of the setting blocks and place them into the sill (Figure C2).
 3. Place the insert in the center of the opening.
 4. Fix in center of opening by inserting setting blocks into the head and lower portion of the jambs.
 5. Finish installation by inserting glass stops to secure the insert into the 3800-T frame (Figure C3).

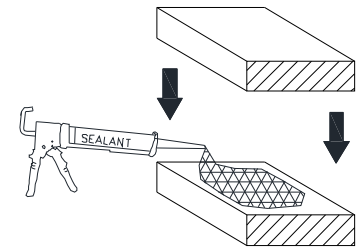

Figure C1:
Bond Setting blocks

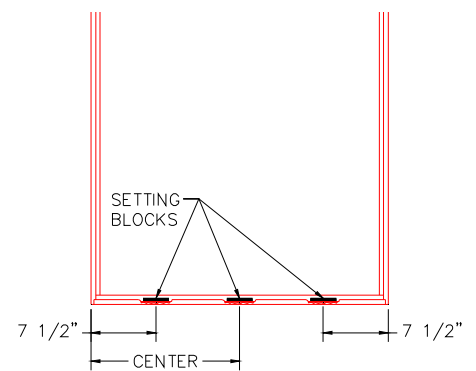

Figure C2:
Setting Blocks Locations

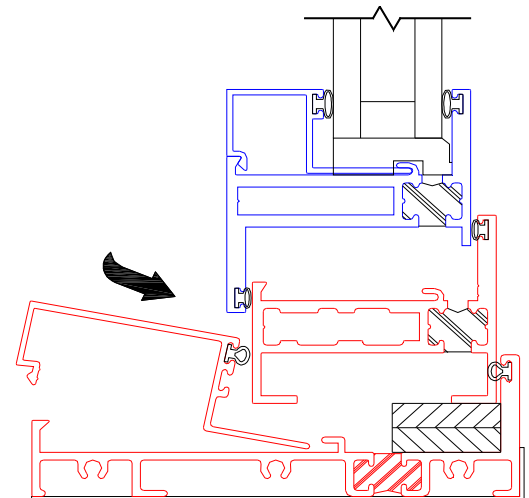

Figure C3:
Inserting Glass Stops (Series 350-T Shown)

Appendix D: CLiC Glass Installation

Fleetwood offers CLiC on demand Privacy Glass as a glazing option. This type of glazing option requires power to be run to each lite using cardinals proprietary glass controller. Depending on the type of product ordered, the wire leads locations will vary. Please ask at the time of purchase to confirm where these leads will be located so assist in preparing the opening accordingly.

Below are links to CLiC glass specific installation instructions:

[Quick Start Guide](#)

[Installation Manual](#)

[Technical Data Sheet](#)