

ASSEMBLY / PARTS LIST (B.O.M.)

Series: 3200-T
Type: HH Configuration

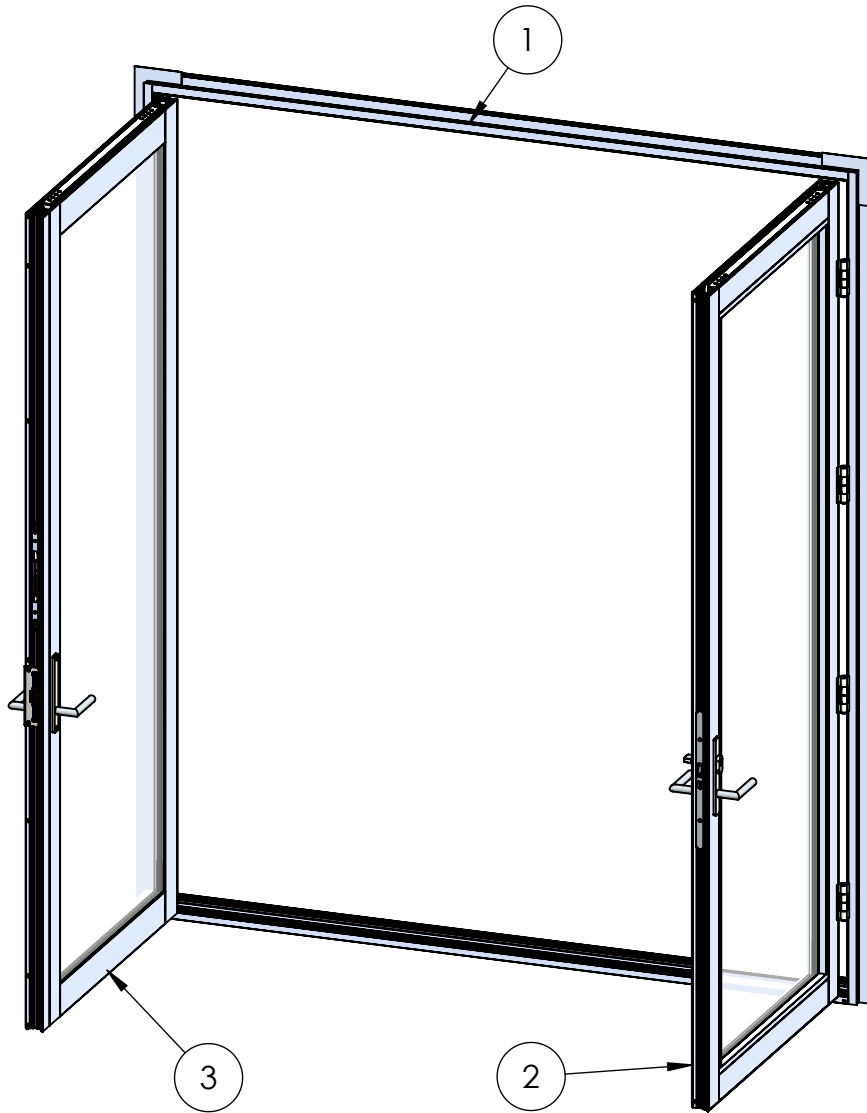

TABLE OF CONTENTS			
ITEM NO.	DESCRIPTION	QTY.	PAGE #
1	Frame Assembly	1	2-3
2	Active Panel Assembly	1	4-5
3	In-Active Panel Assembly	1	6-7
4	Tables	1	8

Out-Swing
Door Shown

PROPRIETARY AND CONFIDENTIAL
THE INFORMATION CONTAINED IN THIS DRAWING IS THE SOLE PROPERTY OF FLEETWOOD WINDOWS & DOORS.
ANY REPRODUCTION IN PART OR AS A WHOLE WITHOUT THE WRITTEN PERMISSION OF FLEETWOOD WINDOWS & DOORS IS PROHIBITED.

Description Table of Contents	
File Name Series 3200-T HH Assembly	REV F
Released 2/16/2026	SHEET 1 OF 8

ASSEMBLY / PARTS LIST (B.O.M.)

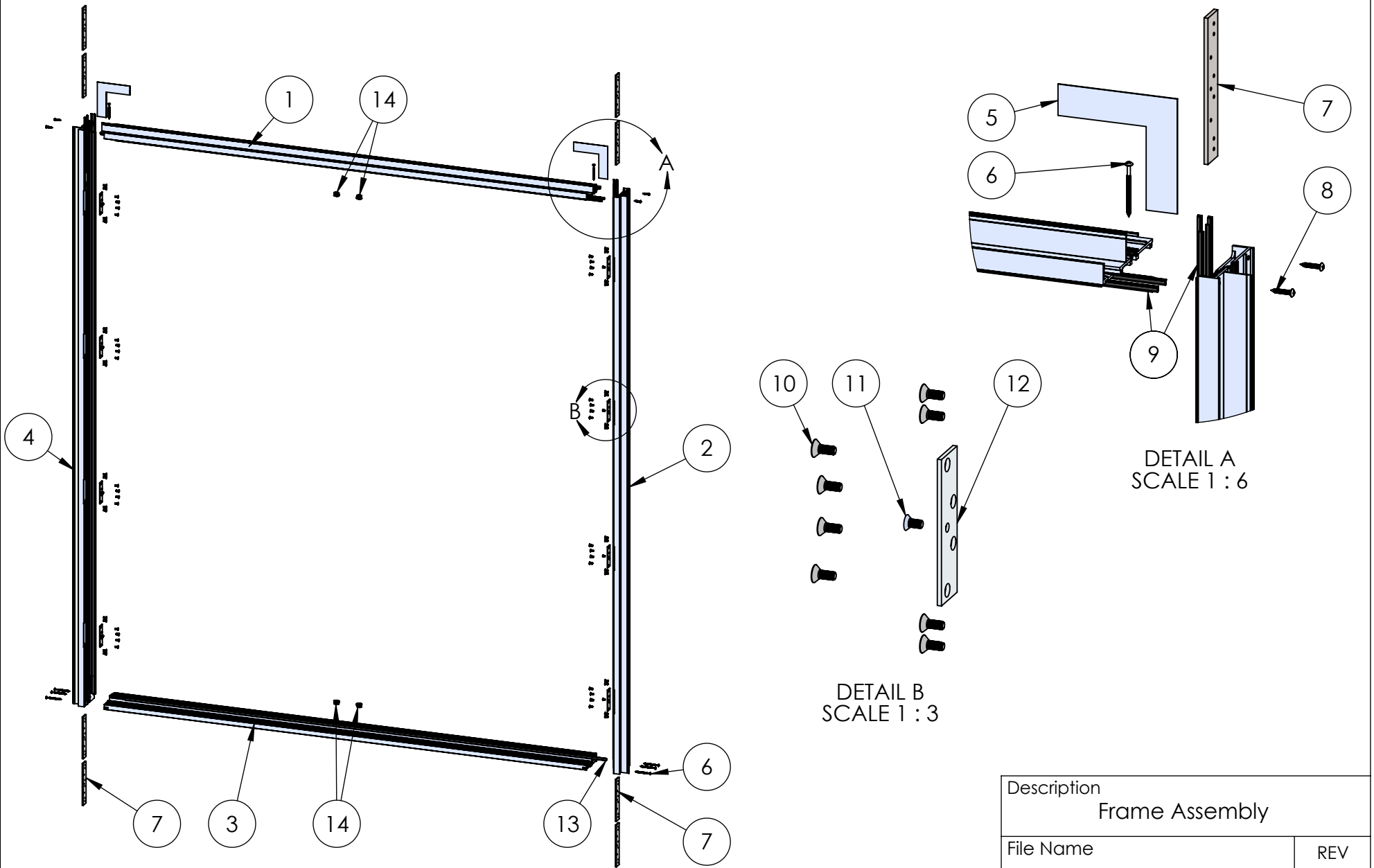

PROPRIETARY AND CONFIDENTIAL
 THE INFORMATION CONTAINED IN THIS DRAWING IS THE SOLE PROPERTY OF FLEETWOOD WINDOWS & DOORS.
 ANY REPRODUCTION IN PART OR AS A WHOLE WITHOUT THE WRITTEN PERMISSION OF FLEETWOOD WINDOWS & DOORS IS PROHIBITED.

Description Frame Assembly	
File Name Series 3200-T HH Assembly	REV F
Released 2/16/2026	SHEET 2 OF 8

ASSEMBLY / PARTS LIST (B.O.M.)

EXTRUSIONS

ITEM NO.	PART NUMBER	DESCRIPTION	QTY.
1	3207,3208,3209	Head (Block, Out-Swing, In-Swing)	1
2	3207,3208,3209	Hinge Jamb (Block, Out-Swing, In-Swing)	1
3	3202,3904,3510	Sill (Out-Swing, In-Swing, 1/2" Sill)	1
4	3207,3208,3209	Hinge Jamb (Block, Out-Swing, In-Swing)	1

HARDWARE

ITEM NO.	PART NUMBER	DESCRIPTION	QTY.
5	18629	Metal Corner w/ Double sided tape	2
6	25075	#10 PHP-A, 2.5", SS, Clear	8
7	25192	Hinge Back Up Plate-Frame	8
8	20350	#10 PHP-A, 1", SS, Clear	4
9	25190	Q-Lon Foam Seal (0.250 x 0.190)	20
10	25486, 25487	#10-32 FH Torx Screw, 0.5", SS (CLR, BLK)	64
11	20266	#10-32 FHP-B-UC, .375", SS, Clear	8
12	25202	Hinge Back Up Plate Spacer -Frame	8
13	25059	Q-Lon Foam Seal (QEZ 376)	1
14	27460	Oval Shootbolt Cup	4

Description Frame B.O.M.	
File Name Series 3200-T HH Assembly	REV F
Released 2/16/2026	SHEET 3 OF 8

ASSEMBLY / PARTS LIST (B.O.M.)

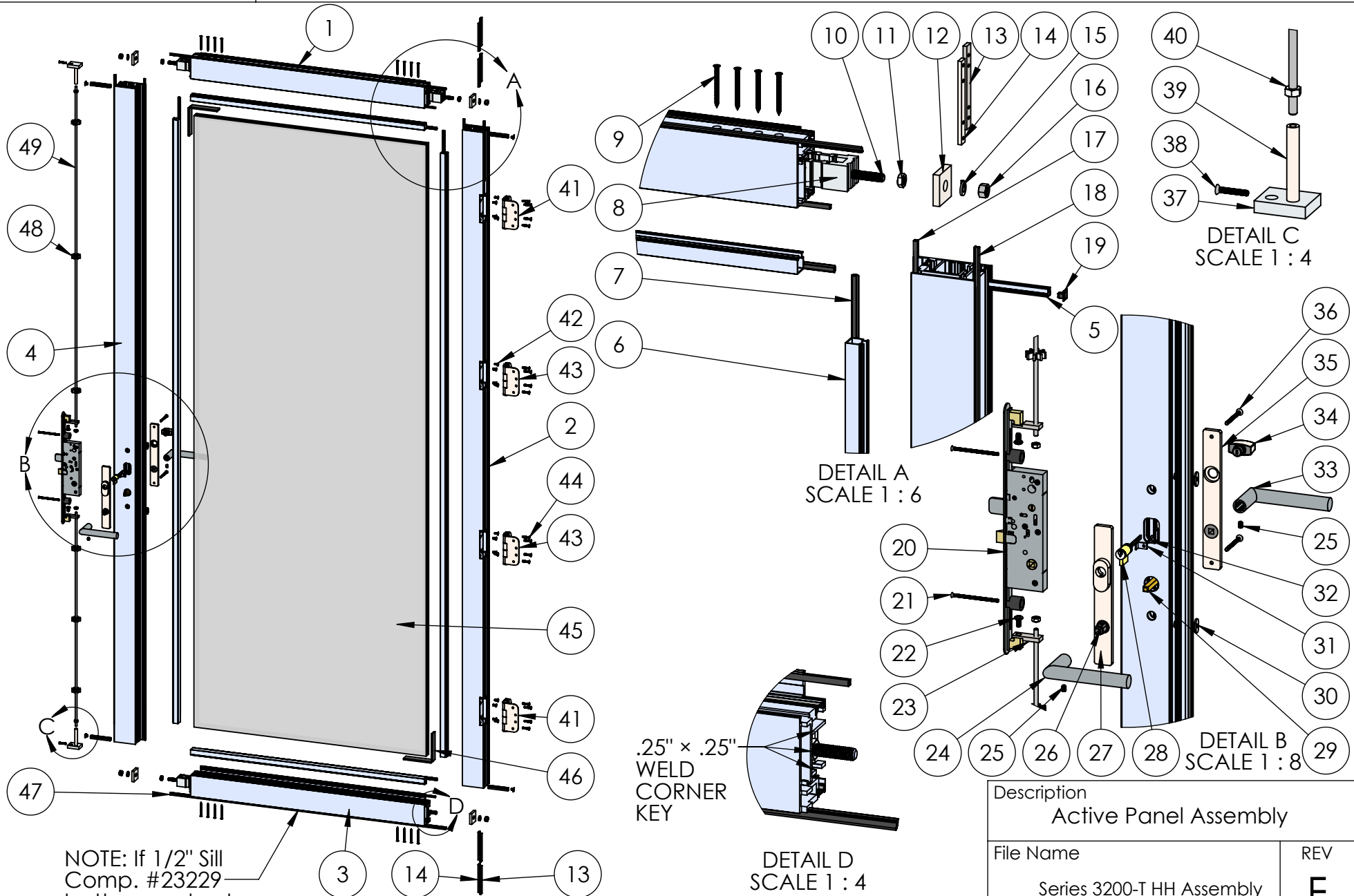

PROPRIETARY AND CONFIDENTIAL
THE INFORMATION CONTAINED IN THIS DRAWING IS THE SOLE PROPERTY OF FLEETWOOD WINDOWS & DOORS.
ANY REPRODUCTION IN PART OR AS A WHOLE WITHOUT THE WRITTEN PERMISSION OF FLEETWOOD WINDOWS & DOORS IS PROHIBITED.

Description Active Panel Assembly	
File Name Series 3200-T HH Assembly	REV F
Released	2/16/2026
SHEET 4 OF 8	

ASSEMBLY / PARTS LIST (B.O.M.)

EXTRUSIONS			
ITEM NO.	PART NUMBER	DESCRIPTION	QTY.
1	3203	Top Rail	1
2	3203	Hinge Stile	1
3	3203	Bottom Rail	1
4	3205	Lock Stile	1
5	3916	Seal Clip	4
6	See Table A	Glass Stop	4

HARDWARE			
ITEM NO.	PART NUMBER	DESCRIPTION	QTY.
7	27685	Medium Bulb Vinyl	4
8	25201	Corner Block	4
9	20256, 20258	#8 FHP-A, 2" SS (BLK, CLR)	16
10	27668	3/8-16 Hex Head Cap Screw, 1.875"	4
11	25176	3/8-16 SS Hex Nut, 7/32"	4
12	25025	Back up Plate Corner Block	4
13	25194	Hinge Interior Back Up Plate	4
14	25195	Hinge Exterior Back Up Plate	4
15	25024	3/8" Split Lock Washer	4
16	25023	3/8-16 SS Hex Nut, 21/64"	4
17	25199	Mini Bulb Vinyl	4
18	25190	Q-Lon Foam Seal (0.250 x 0.190)	6
19	26684	Bottom and Top Clip Cap	4
20	27389	Active 3-Point Lock	1
21	27536	#8-32 FH Torx, 3.00", SS, Clear	2
22	20357	#1/4-20 PHP-B, 1/2", SS, Clear	2
23	27077	Shoot Bolt Adapter	2
24	26189, 26191	FSB_1076 Lever RH (SS, BLK)	1
25	26318	Cup-Point Set Screw M6, 8mm, SS (CLR)	2
26	26212	Bushing/Adaptor for FSB Lever/Escutcheon Plate	2

HARDWARE			
ITEM NO.	PART NUMBER	DESCRIPTION	QTY.
27	27392, 27394	Escutcheon-Active Exterior (SS, BLK)	1
28	25063	Rim Cylinder	1
29	26195	Spindle	1
30	27246	Low-Profile Narrow-Base Weld Nut	2
31	25187	L-Clip (Cylinder Retainer)	1
32	27137	M4 x 0.70 mm Thread, 20mm Long	1
33	26190, 26192	FSB_1076 Lever LH (SS, BLK)	1
34	27396, 27397	FSB Thumbturn Only (Satin, Black)	1
35	27393, 27395	Escutcheon-Active Interior (SS, BLK)	1
36	27531, 27532	#10-32 FH Torx Screw, 2.25", SS (CLR, BLK)	2
37	25205	Shoot Bolt Guide	2
38	26916, 27071	#8-32 Torx FH Screw, 1"/1.125" (CLR, BLK)	2
39	27055	Shoot Bolt Cap	2
40	24893	1/4-20 Hex Nut	4
41	25232, 25236	Adjustable Hinge, Horizontal RH (Satin Nickel, Black)	2
42	25486, 25487	#10-32 FH Torx Screw, 0.5", SS (CLR, BLK)	16
43	25234, 25238	Adjustable Hinge, Vertical Set RH (CLR, BLK)	2
44	25488, 25489	#10-32 FH Torx Screw, 1", SS (CLR, BLK)	16
45	-	Glass	1
46	27313	Setting Block 3/16" x 1" x 4" with adhesive	4
47	25196	Q-Lon Foam Seal, 32390	2
48	25566	Shoot Bolt Rod Guide (Spider)	6
49	27067	1/4-20 Threaded Rod, 18-8 SS, Cut to size	1

Description	
Active Panel B.O.M.	
File Name	REV
Series 3200-T HH Assembly	F
Released	SHEET 5 OF 8
2/16/2026	

ASSEMBLY / PARTS LIST (B.O.M.)

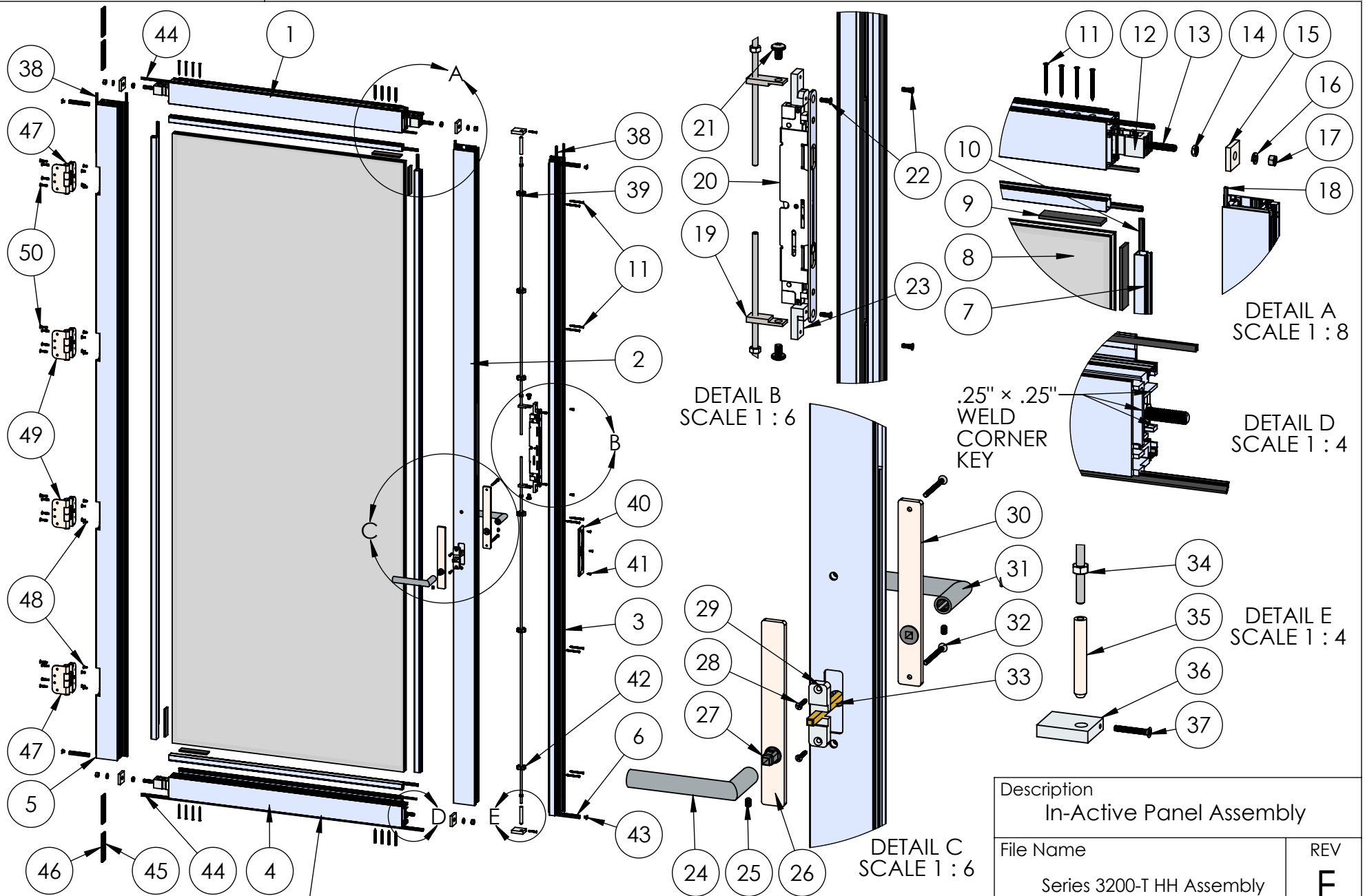

NOTE: If ADA Door Comp. #23229 bottom seal only

PROPRIETARY AND CONFIDENTIAL
THE INFORMATION CONTAINED IN THIS DRAWING IS THE SOLE PROPERTY OF FLEETWOOD WINDOWS & DOORS.
ANY REPRODUCTION IN PART OR AS A WHOLE WITHOUT THE WRITTEN PERMISSION OF FLEETWOOD WINDOWS & DOORS IS PROHIBITED.

Description In-Active Panel Assembly	
File Name Series 3200-T HH Assembly	REV F
Released	2/16/2026
SHEET 6 OF 8	

ASSEMBLY / PARTS LIST (B.O.M.)

EXTRUSIONS

ITEM NO.	PART NUMBER	DESCRIPTION	QTY.
1	3203	Top Rail	1
2	3205	In-Active Stile	1
3	3206	Astragal	1
4	3203	Bottom Rail	1
5	3203	Hinge Stile	1
6	3916	Seal Clip	4
7	See Table A	Glass Stop	4

HARDWARE

ITEM NO.	PART NUMBER	DESCRIPTION	QTY.
8	-	Glass	1
9	27313	Setting Block 3/16" x 1" x 4" with adhesive	4
10	27685	Medium Bulb Vinyl	4
11	20256, 20258	#8 FHP-A, 2" SS (BLK, CLR)	26
12	25201	Corner Block	4
13	27668	3/8-16 Hex Head Cap Screw, 1.875"	4
14	25176	3/8-16 SS Hex Nut, 7/32"	4
15	25025	Back up Plate Corner Block	4
16	25024	3/8" Split Lock Washer	4
17	25023	3/8-16 SS Hex Nut, 21/64"	4
18	25199	Bulb Vinyl Mini	5
19	27077	Shoot Bolt Adapter	2
20	25223	Flush Bolt Latch, Backset 30mm	1
21	25344	M8 PHP Machine screw, 12mm, SS	2
22	25497	#8-32 FHP, UC, 1/2", SS (CLR)	4
23	25206	In-Activated Gear Back Up Block	2
24	26190, 26192	FSB_1076 Lever LH (SS, BLK)	1
25	26318	Cup-Point Set Screw M6, 8mm, SS (CLR)	2
26	27521, 27523	Escutcheon Inactive Exterior Handle (SS, BLK)	1
27	26212	Bushing/Adaptor for FSB Lever/Escutcheon Plate	2
28	20247, 20248	#8 FHP-A, 1", SS (CLR, BLK)	2

HARDWARE

ITEM NO.	PART NUMBER	DESCRIPTION	QTY.
29	25218	Dummy Handle Adaptor	1
30	27522, 27524	Escutcheon Inactive Interior Handle (SS, BLK)	1
31	26189, 26191	FSB_1076 Lever RH (SS, BLK)	1
32	27531, 27532	#10-32 FH Torx Screw, 2.25", SS (CLR, BLK)	2
33	26195	Spindle	1
34	24893	1/4-20 Hex Nut	4
35	27055	Shoot Bolt Cap	2
36	25205	Shoot Bolt Guide	2
37	25343	#8-32 FHP Machine Screw, 1.125"	2
38	25190	Q-Lon Foam Seal (0.250 x 0.190)	1
39	27067	1/4-20 Threaded Rod, 18-8 SS, Cut to size	2
40	27528	Latch/Deadbolt Strike Plate SS (Modified 24993)	1
41	20240	#8 FHP-A-UC, 0.5", SS, Clear	3
42	25566	Shoot Bolt Rod Guide (Spider)	6
43	26684	Bottom and Top Clip Cap	4
44	25196	Q-Lon Foam Seal, 32390	2
45	25194	Hinge Interior Back Up Plate-Panel	4
46	25195	Hinge Exterior Back Up Plate-Panel	4
47	25231, 25235	Adjustable Hinge, Horizontal LH (Satin Nickel, Black)	2
48	25486, 25487	#10-32 FH Torx Screw, 0.5", SS (CLR, BLK)	16
49	25233, 25237	Adjustable Hinge, Vertical Set LH (Satin Nickel, Black)	2
50	25488, 25489	#10-32 FH Torx Screw, 1", SS (CLR, BLK)	16

Description
In-Active Panel B.O.M.

File Name
Series 3200-T HH Assembly

REV
F

Released 2/16/2026

SHEET 7 OF 8

PROPRIETARY AND CONFIDENTIAL

THE INFORMATION CONTAINED IN THIS DRAWING IS THE SOLE PROPERTY OF FLEETWOOD WINDOWS & DOORS.
ANY REPRODUCTION IN PART OR AS A WHOLE WITHOUT THE WRITTEN PERMISSION OF FLEETWOOD WINDOWS & DOORS IS PROHIBITED.

ASSEMBLY / PARTS LIST (B.O.M.)

TABLE A: Glass Stop Options	
Glass Thickness	ID
9/16"	3924
1"	3907
1-1/4"	4735
1-1/2"	4736

Description	
Tables	
File Name	REV
Series 3200-T HH Assembly	F
Released	SHEET 8 OF 8
2/16/2026	