

Table of Contents

I.	Care and Maintenance	2
II.	Tools / Materials, Sealant Requirements, & Anchor Instructions.....	2
III.	Assembly and Installation	2
IV.	Glazing Assembly	3
V.	Panel Assembly.....	3
	“X” Panel.....	3
	“O” Panel.....	5
	“O” Panel (non-interlocker).....	5
	Add Yokes to Meeting Stiles.....	6
VI.	Frame Assembly	6
VII.	Frame Opening Verification & Sillpan Installation.....	7
	1. Sillpan Substitution.....	7
	2. Frame Opening Verification.....	7
	3. Pre-Fit and Leveling	7
	4. Flash the Opening.....	7
	Paper Flashing.....	7
	Liquid Flashing.....	7
	5. Sealant Application.....	8
VIII.	Frame Installation.....	9
IX.	Sill Track Installation	9
X.	Sill Track Removal	10
XI.	Head Bumper Installation (optional)	10
XII.	Panel Installation.....	10
XIII.	Screen Installation	12
XIV.	OXO Panel Configuration	13
XV.	Flashing after Installation.....	15
	Appendix A: Magnetic Latch Instructions	16
	Appendix B: Thermal Narrow Interlocker Glazing	18

I. Care and Maintenance

This product is factory finished. Please handle with extreme care. Protect all exposed surfaces from contact with caustics, corrosives, solvents, abrasions, impacts, wet packing material etc.

FAILURE TO DO SO WILL NULLIFY THE WARRANTY. Before **ANY CLEANING**, review the Care & Maintenance Instructions (go to www.fleetwoodusa.com for more information).

Contact the local dealer with any questions or concerns. Fleetwood strongly recommends that all products be cleaned after installation and totally protected from construction debris and equipment.

II. Tools / Materials, Sealant Requirements, & Anchor Instructions

Tools Required: Tape measure, Level, Shims, Screws, Screw Gun, #2 Phillips Bit, #3 Phillips Screwdriver, Power Drill, Sealant, Caulk Gun, Backer Rod, Utility Knife, Rubber/Plastic Mallet, Pliers, Wax.

Sealant Requirements

- The sealant referred to within this document for seals associated with the assembly of the product should conform to **AAMA 800**. It may be a sealant recommended and approved by the sealant manufacturer that is compatible with the framing, finish, and surrounding materials.
- All sealant bead sizes must conform to the sealant manufacturers' size requirements.
- The Owner / General Contractor is responsible for identifying the need for any additional sealant to be applied by others. Such sealant shall be elastomeric material, with the framing, finish, and surrounding materials.

Anchor Instructions

- Structural engineer to determine anchor quantity, size, and spacing for design load requirements.
- Proper material must be used between all dissimilar surfaces (i.e. block/concrete & aluminum).

III. Assembly and Installation

Note: Add tube wax lubricant to the ends of all fasteners to reduce the drive torque required for installation, apply a small amount of tube wax to the head of the fasteners to assist with installation.

It is essential that each Fleetwood product be assembled and glazed in accordance with AAMA standards and factory instructions. It is the installer's responsibility to ensure that each Fleetwood product is assembled, glazed and installed and completely sealed to ensure that the product is leak-free and operates correctly. **Installation of Fleetwood products must be in accordance with the standards set forth in ASTM E 2112.** If there are any questions regarding the installation of a Fleetwood product contact the factory customer service department.

IV. Glazing Assembly

1. Start attachment of glazing vinyl at top corner of the glass.
2. Cut glazing vinyl at corners as shown in Figure 1, Detail "A".
3. At start/end point (seam), cut glazing vinyl 1/8" oversize to compensate for stretching.
4. Apply sealant to top portion of this seam.
5. Apply a bead of sealant that is compatible with the insulated glass seal to all four exterior corners as shown in Figure 1, Detail "A".

Notes:

- a. The glass thickness, net width and height must be to size within $\pm 1/32"$.
- b. If the chosen interlocker is any combination of the Narrow Thermal Interlocker an additional 5" section of silicone will be required at the middle of the interlocker. See Appendix B.
- c. Failure to install according to these instructions nullifies all warranties related to this product.

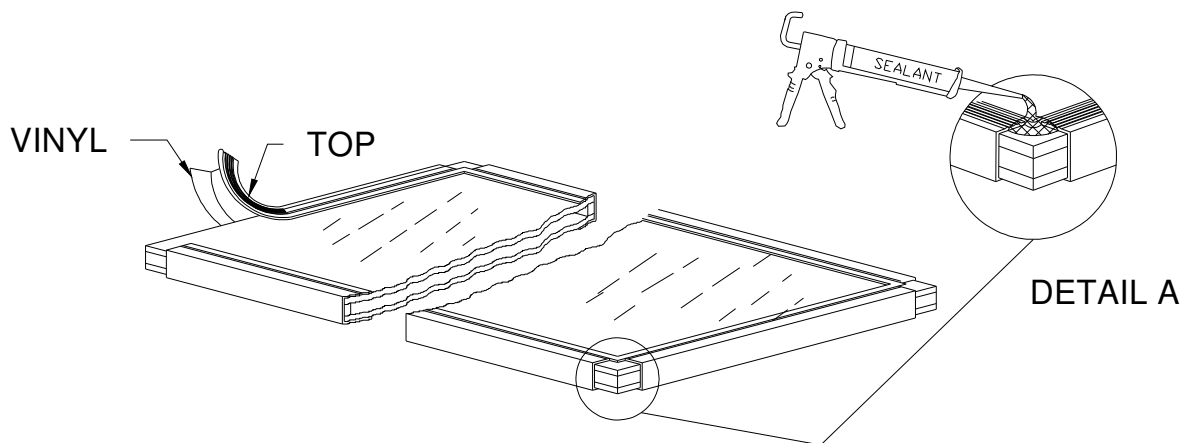

Figure 1:
Glazing Vinyl Application

V. Panel Assembly

Note: Match door configuration and panel orientation with customer order. Configuration and orientation of panels shown in assembly instructions is for illustration purposes only.

"X" Panel

1. Adjust the roller assemblies (2 required per "X" panel) to the full up right position using the adjustment screw (Figure 2).
2. Center the top rail onto the glass. Using a rubber mallet, drive the rail onto the glass until the rail seats against the vinyl lip. Repeat this procedure with the bottom rail.
3. Slide the Vinyl sweep into the top groove of the bottom rail 13/16" on interlocker side and 2 3/4" on lead stile side.

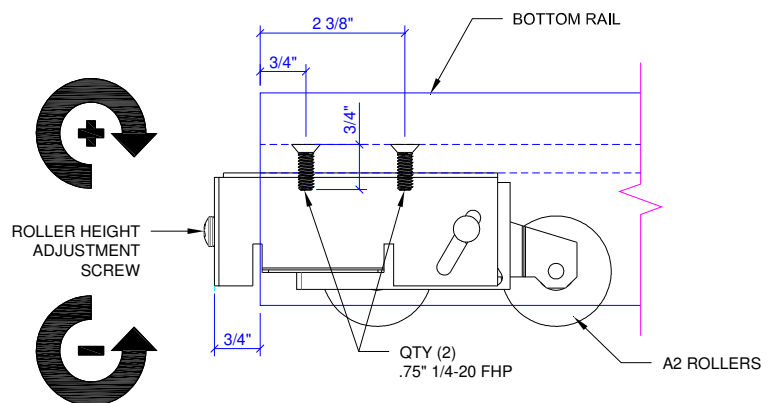

Figure 2:
Roller Adjustment

Note: Prior to adjusting the roller on **ANY** door you **MUST** first remove the weight of the panel.

Note: Before installing lead and interlocker stiles to panels please check required orientation with customer order

4. Place the interlock stile; weather-strip facing up on the right side for XO, and weather-strip facing up on the left side for OX.
5. Position the interlocker stile on one side as described above and drive it onto the glass.
6. Position the lead stile or interlocker stile on other side and drive it onto the glass.
7. Secure the stiles to the rails with (4) #8 x 3 1/2" flat head screws in the top and bottom rails for the interlockers and (4) #8 x 2 1/2" pan head screws for lead stile (Figures 3 & 4).
8. Secure the bottom vinyl with the vinyl clip as shown.

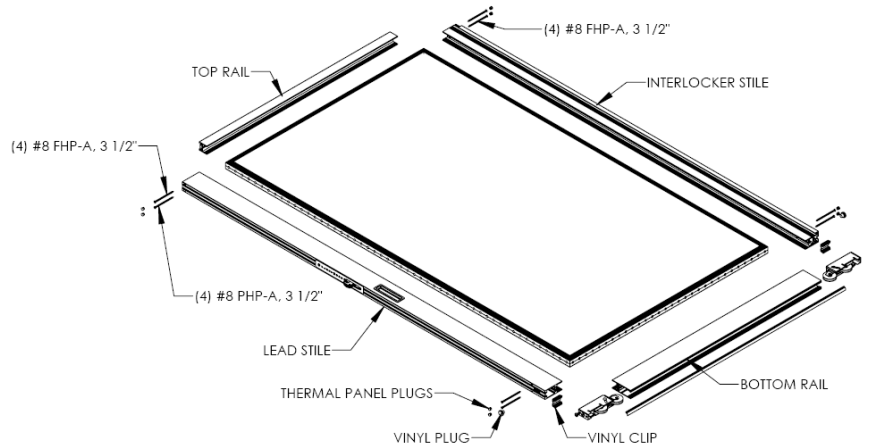
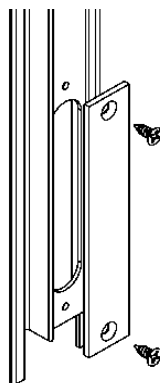

Figure 3:
"X" Panel Assembly (exterior)

General Rules: On panel and stile orientation operating hardware or thumb turns are always to the interior. On panels with interlocker stiles at both ends, weather stripping should be oriented so that one end is facing up and the other facing down.



On doors with meeting stiles, a stainless steel cover is provided to cover the oblong holes at the bottom of the lead stiles.

Figure 4a:
Meeting Stile Cover plate

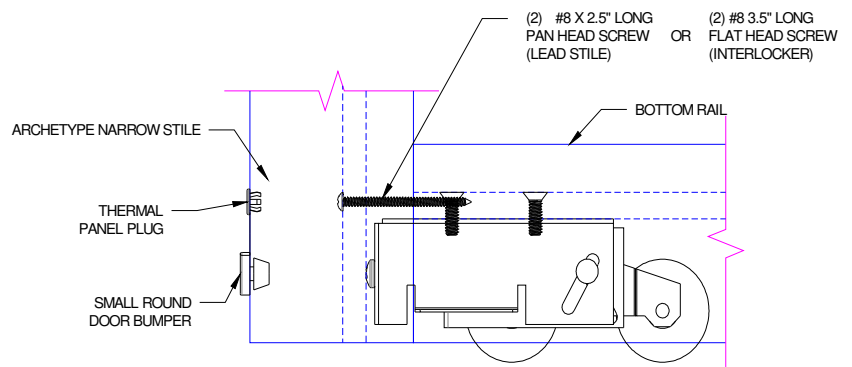

Figure 4b:
Roller Fastening

“O” Panel

1. Center the top rail onto the glass. Using a rubber mallet, drive the rail onto the glass until the rail seats against the vinyl lip. Repeat this procedure with the bottom rail.

Note: Before installing fixed and interlocker stiles to panels please check required orientation with customer order.

2. Place the interlock stile; weather-strip facing down on the right side for OX, and weather-strip facing down on the left side for XO.
3. Position the interlocker stile on one side as described above and drive it onto the glass.
4. Position the fixed stile or interlocker stile on other side and drive it onto the glass.
5. Finish assembly by inserting (4) #8 x 3 1/2" flat head screws into the interlocker, and (4) #8 x 2" pan head screws into the fixed stile screw grooves in the top and bottom rails (Figure 5). Add wax to the ends of all fasteners to reduce the drive torque required for installation.
6. Insert vinyl plugs at top and bottom of stiles.

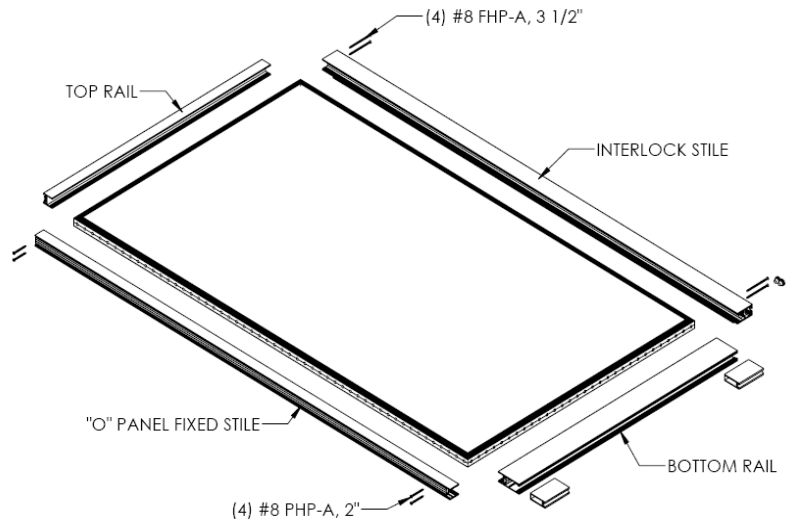

Figure 5:
 “O” Panel assembly
 (interior)

“O” Panel (non-interlocker)

1. Center the top rail onto the glass. Using a rubber mallet, drive the rail onto the glass until the rail seats against the vinyl lip. Repeat this procedure with the bottom rail.
2. Position the fixed stiles on sides and drive it onto the glass.
3. Finish assembly by inserting (8) #8 x 2" pan head screws into the fixed stile screw grooves in the top and bottom rails (Figure 6). Add wax to the ends of all fasteners to reduce the drive torque required for installation.

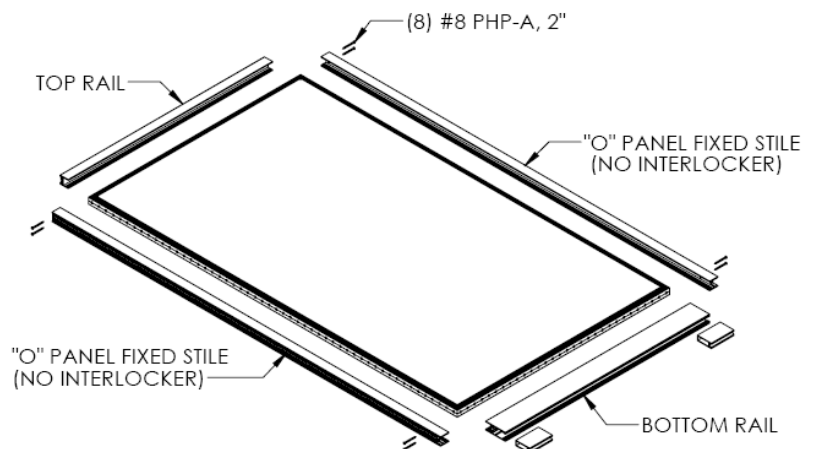

Figure 6:
 “O” Panel assembly non-interlocker

Add Yokes to Meeting Stiles

General Rules: Latching hardware for typical installation is located in the right hand panel (facing exterior); customer has option to reverse at the time of order. Female yoke is attached to the stile containing the latch mechanism.

1. Install male and female yokes with #8 x 3/4" screws, 6" from ends, maximum 18" on centers (Figure 7).

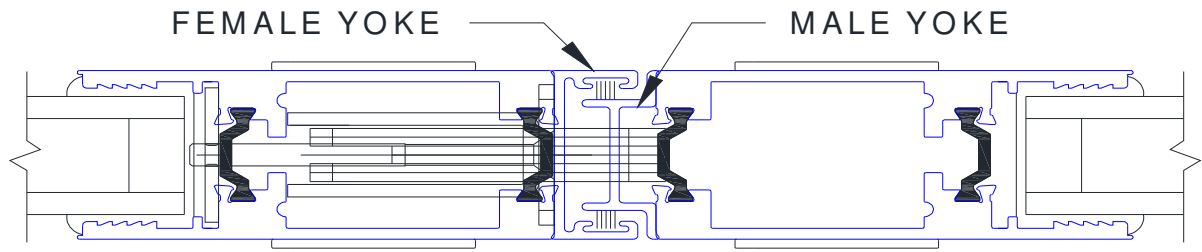

Figure 7:
In-Line Meeting Stiles

VI. Frame Assembly

Note:

- Due to the potential disruption during handling and installation, the installer is responsible for the integrity of all areas requiring sealant whether or not these frames were factory assembled.
 - Add wax to the ends of all fasteners to reduce the drive torque required for installation.
 - Check that the screws pass through jamb(s) and into the screw raceways (at the head and sill).
1. Add sealant to the upper corners of the jamb(s) and to the end of the head that is compatible to the entire assembly as shown in Figure 8, Detail A.
 2. Attach the jamb(s) to the head using #10 x 3/4" long pan head screws.
 3. Attach the jamb(s) to the sill using #10 x 3/4" long pan head screws.
 4. After frame has been assembled make sure ample sealant is forced in and around each contour at all four corners as shown in Figure 8, Detail B. Seal outside corners from underneath threshold as shown in Figure 8, Detail C.

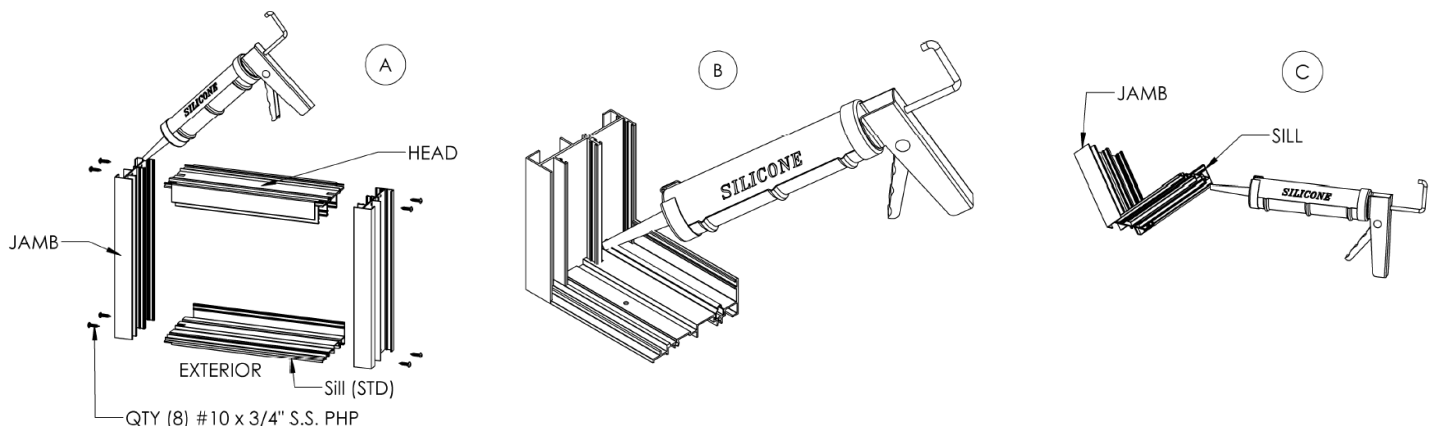

Figure 8:
Frame Joint Sealing

VII. Frame Opening Verification & Sillpan Installation

1. Sillpan Substitution

- If the factory provided sillpan is not desired, the product warranty will remain intact if the substitute panning system emulates the essential design of the factory pan. This sliding door has passed specific air, water, energy and structural testing with the factory provided sillpan.

2. Frame Opening Verification

- Check the measurements of the opening and verify that the door will fit into the opening. Measure all four sides of the opening to make sure there is a clearance of 1/2" in width and 1/4" in height.
- Remove the door(s) from the packaging and lay it in front of the opening. Check width and height dimensions.
- Verify the opening is plumb and level.

3. Pre-Fit and Leveling

- Place sillpan into the opening and determine leveling that must be done prior to installation.
- Shim as necessary to stabilize the entire depth and length of the sillpan. No unsupported width of more than 8" is allowed.
- If more than 1/8" shim height is required, pouring self-leveling "Rock Hard" (or equal) to achieve a level and stable surface is recommended.

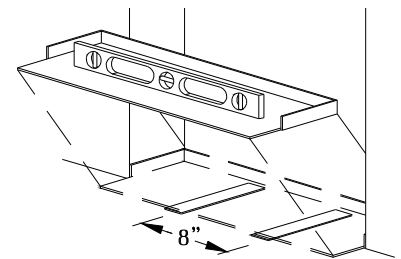

Figure 9:
Leveling Sillpan

4. Flash the Opening

- Once the opening has been confirmed, flashing of the opening is required prior to Frame installation. Paper and/or liquid flashing methods are acceptable (see AAMA 711/714 for material requirements).
- Check local Building codes for any additional flashing requirements.

Paper Flashing

- At each Jamb the flashing paper should be cut at least 3" past the weep-screed or diado flashing and at least 6" above the head of the door. The flashing must wrap around the jamb and at least 3" back into the opening.
- At the Head run the flashing paper long enough to extend at least 3" past the jamb flashing and wrap around the Header at least 3" into the opening.

Liquid Flashing

- Follow the liquid flashing manufacturer instructions.

5. Sealant Application

- Apply sealant in all corners and seams of the sillpan (Figure 10).
- With bottom side of sillpan up, apply a 3/8" bead of compatible sealant 1/2" in from interior leg. Sealant bead to run across the bottom as well as up each vertical leg of the sillpan. Also apply sealant beads near the sides and across the front (Figure 11).

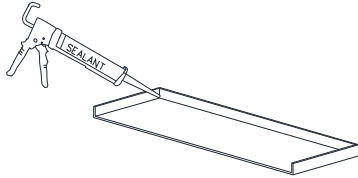

Figure 10:
Seal corners and seams

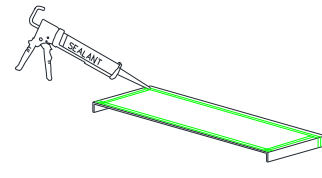

Figure 11:
Seal underside of Sillpan

- Secure the sillpan to the floor with sealant (Figure 12). Position sillpan as necessary to allow for proper installation of frame assembly.
- If sillpan is more than one piece, butt the pieces and glue them to the floor together (Figure 13).
- Apply sealant to all interior and exterior seams.

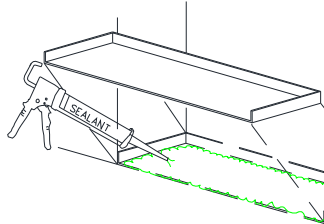

Figure 12:
Set Pan in full bed
of sealant

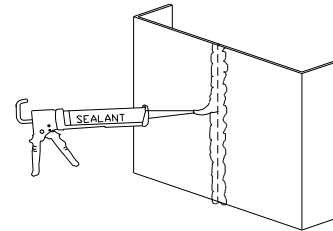

Figure 13:
Glued Sillpans

VIII. Frame Installation

1. Attach sill to the sillpan with a compatible sealant as shown in Figure 14.
2. Attach frame to structure as shown below (Figures 15 & 16).

Note: Size, quantity, and location of fasteners to be per local code. Blocking, stainless-steel screws (recommended), and wall finish not furnished by Fleetwood. Frame installation anchors furnished by installer.

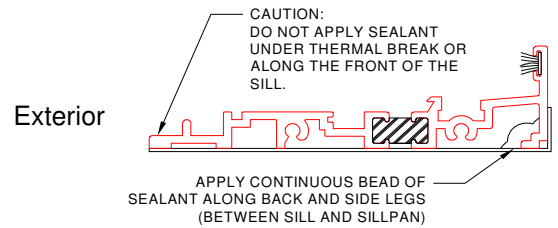

Figure 14:
Attached Sill

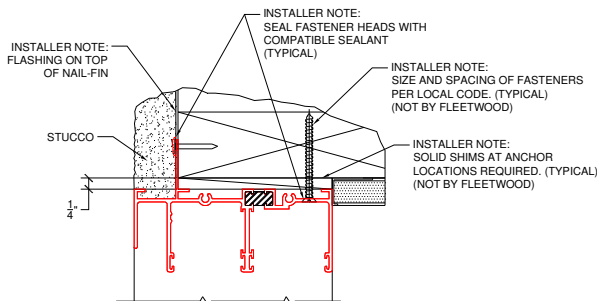

Figure 15:
Nail-fin Anchoring

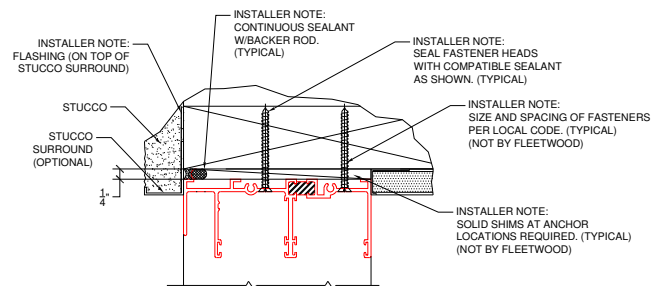
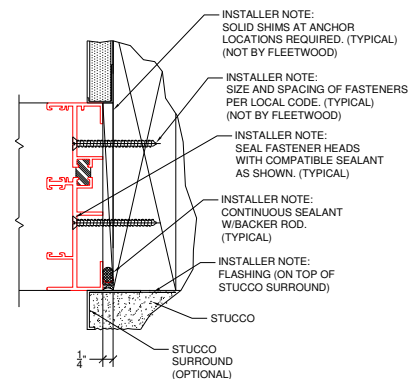
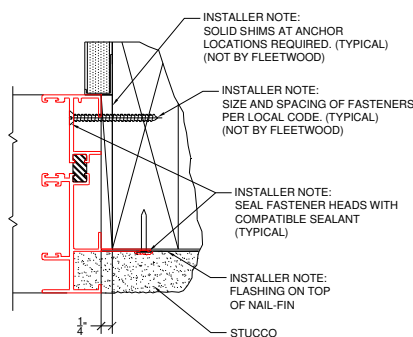

Figure 16:
Block Frame Anchoring



IX. Sill Track Installation

1. Using a pair of pliers, slightly squeeze one end of the track to create a tapered edge.
2. Push tapered edge of track into the sill.
3. Using a rubber mallet, tap the track into the sill.

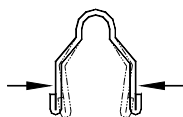

Figure 17:
Squeeze track

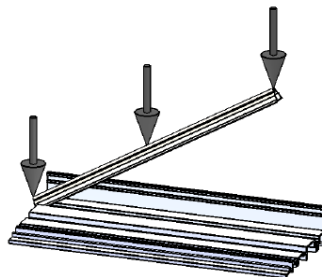

Figure 18:
Sill Track Installation

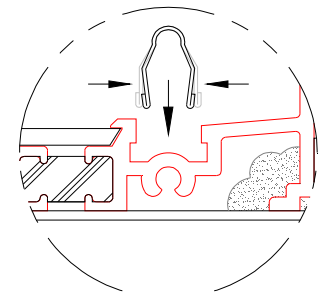

Figure 19:
Track (Typical)

X. Sill Track Removal

1. Using a pair of pliers, slightly squeeze the track together at one end and pull up.
2. Using a screwdriver, slowly pry the track out of the sill. Although you can re-insert the track, we recommend replacing with a new track for optimal performance of the door.

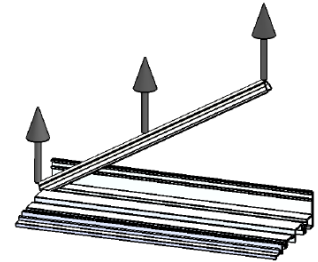

Figure 20:
Sill Track Removal

XI. Head Bumper Installation (optional)

1. Install head bumpers into head as shown.

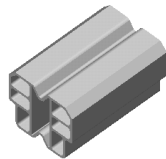

Figure 21:
Head Bumper

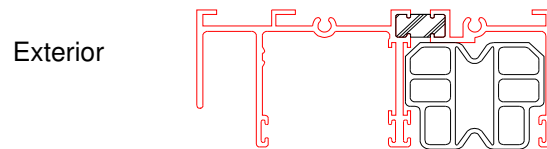

Figure 22:
Head Bumper Installation

XII. Panel Installation

Note: Check customer order for proper panel configuration and orientation.

“X” Panel

1. Sequence of panel installation is from interior to exterior.
2. Insert panel (panel located on the track closest to the interior) into the upper head channel. Push up and swing the bottom inward until panel is vertical, then lower panel down onto the track (Figure 23).

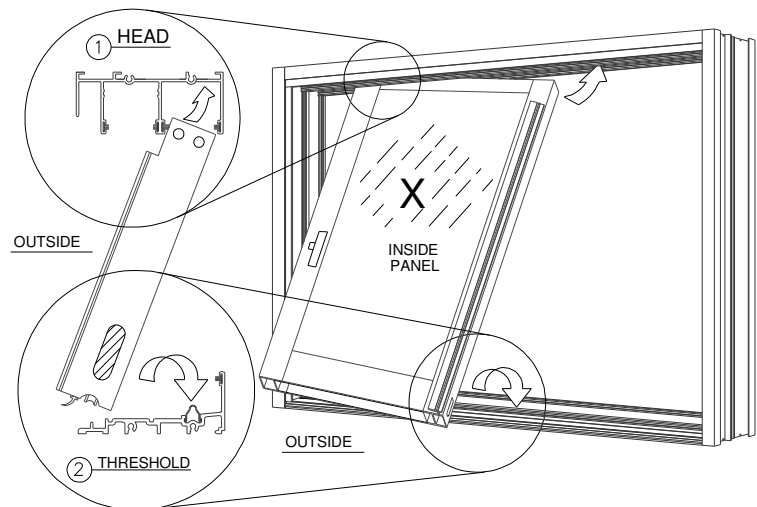

Figure 23:
“X” Panel Installation

Note: “X” Panel - Do not attempt to slide the panel unless the rollers have been adjusted. Adjust the rollers as needed to make the panel plum and level. If the panel contains a lock stile, verify that the latch height is correct for proper operation with the frame. Insert vinyl plugs into the holes at top and bottom of the panel.

“O” Panel Installation

1. Add 2” long sill block and secure with #8 x 3/4” long pan head self tapping screw to the bottom of sill as shown in Figure 24. Remove and set aside the screw that is provided with the sill block for step 3.
2. Insert panel into the upper head channel. Push up and swing the bottom inward until panel is vertical, then lower panel down onto the track.

Note: “O” Panel - Lift and move the panel into the fixed jamb as far as possible. Verify that the weather stripping in the frame head is located so that it contacts the width of the “O” panel.

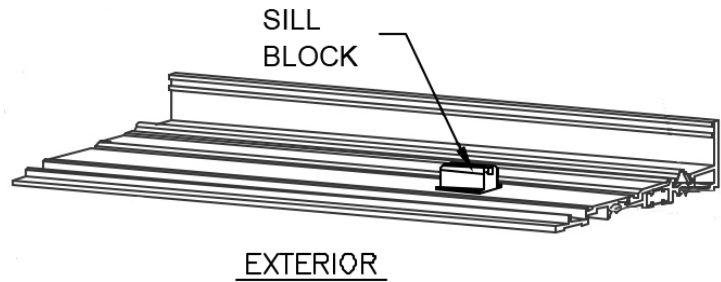

Figure 24:
Attached Sill Block

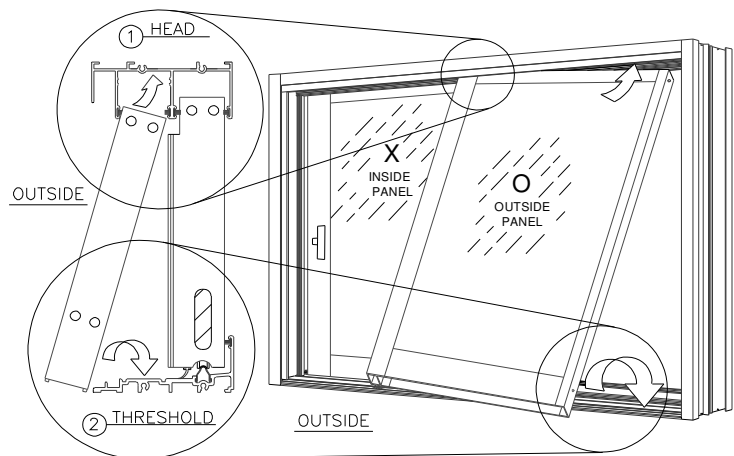

Figure 25:
“O” Panel Installation

3. **Installing the fixed panel security screw:** Using a 1/8” drill bit, drill a hole into the fixed stile below the glass as shown in Figure 26. Then insert a black #8 x 3/4” PHP TEK security screw. Fasten the panel to the sill block using the provided #10 OH - A, 2.5, Zinc, Gold screw (Figure 26).

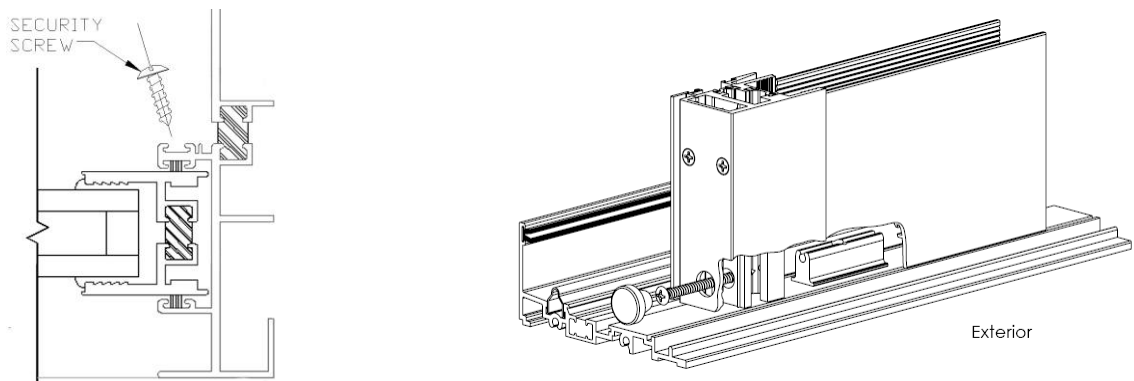

Figure 26:
Security Screw Installation

XIII. Screen Installation

1. Insert screen into the upper head channel. Push up and swing the bottom inward until screen is vertical, then lower screen down onto the track.

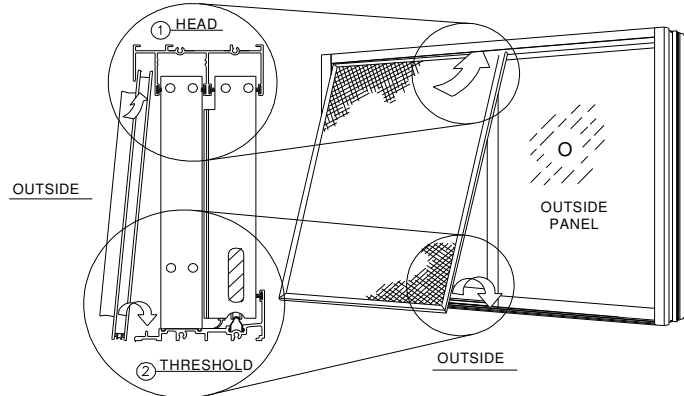

Figure 27:
Screen Installation

2. Verify that all panels with interlocker hooks engage properly. If lead stile panel is not engaging properly with the jamb or meeting stiles (Figure 28).
3. Repeat previous step until all panels have been installed properly.
4. (Optional) To reduce air infiltration, snap two 6" plastic air barriers in the back of all exterior interlockers at the top and bottom (Figure 28).

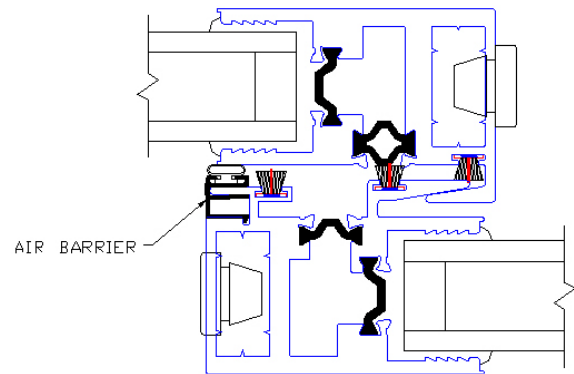

Figure 28:
Interlockers with Air Barrier

Note: panels must overlap during installation to allow proper engagement of interlockers.

5. Install head closer(s) into the head except where the closer interferes with sliding panel(s) (Figure 29).

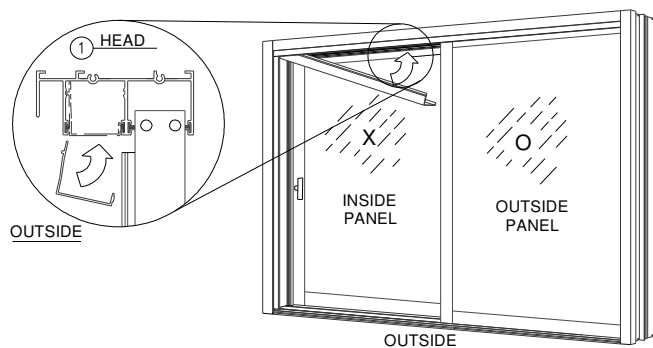

Figure 29:
Head Closer Installation

XIV. OXO Panel Configuration

Note: OXOL Shown, OXOR Opposite. Check customer order for proper panel configuration and orientation. Assemble and install the frame as indicated on previous sections III – VIII of this manual. Insert the sliding panels as indicated on previous section “XO” Panel Configuration, once completed then continue with following instructions for OXO panel installation completion.

1. Slide the “X” Panel to the right side fixed jamb.
2. Insert the left side fixed panel (without interlocker) into the upper head channel. Push up and swing the bottom inward until panel is vertical, then lower panel down onto the track.

Note: Leave the head unanchored until the false jamb has been installed and set into position.

3. Slide the left side fixed panel into the left side fixed jamb as far as possible.
4. Install the false jamb at an angle until it rests against the left side fixed panel (Figure 31).
5. Using a wood block and hammer, set the false jamb firmly into its place against the fixed panel.
6. Install the head closer between the false jamb and the right side fixed panel (Figure 32).

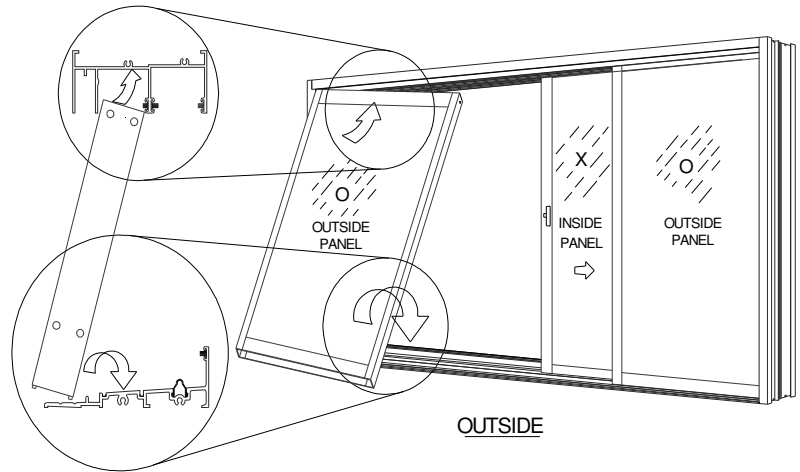

Figure 30:
OXO Panel Installation

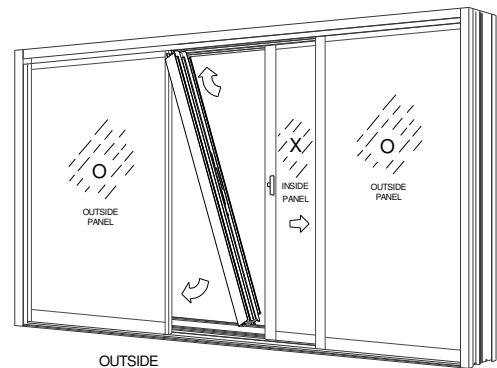

Figure 31:
False Jamb Installation

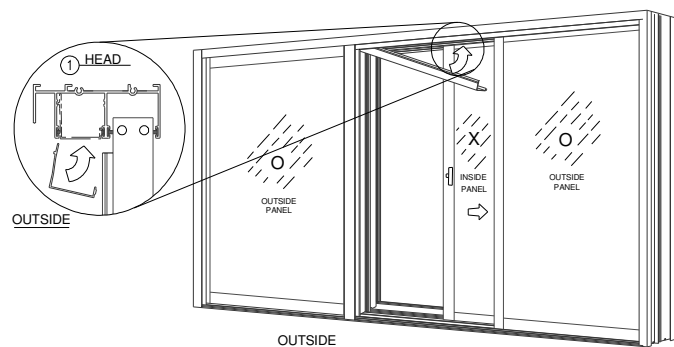

Figure 32:
Head Closer Installation

7. Anchor False Jamb to the Frame and Structure

- Add the Sill Block using (1) #8 PHP-TEK, 3/4" screw (Figure 33).
- Attach the false jamb to the sill block using a (1) #10 PHP-A, 3" screw.
- Add (4) #8 PHP-TEK, 3/4" screw along the false jamb interior of fixed panel (Figure 34).
- Using (4) #8 x 3/4" long pan head self-tapping screws (Figure 34).
- Seal all the holes.

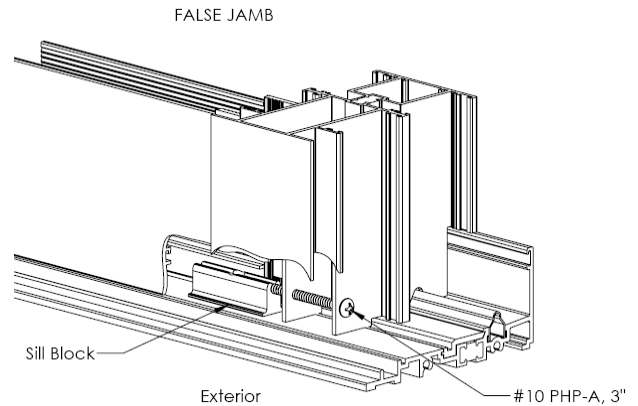

Figure 33:
Sill Block at False Jamb

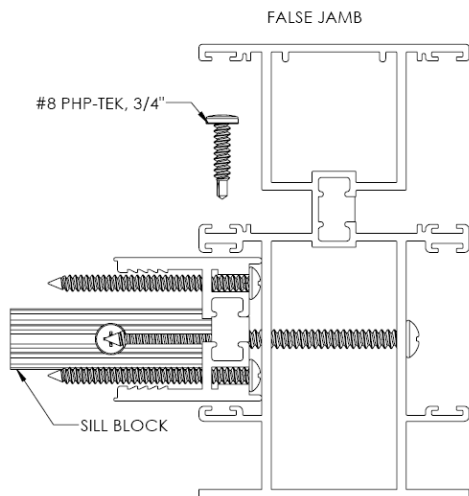

Figure 34:
Security screw at fixed panel and False

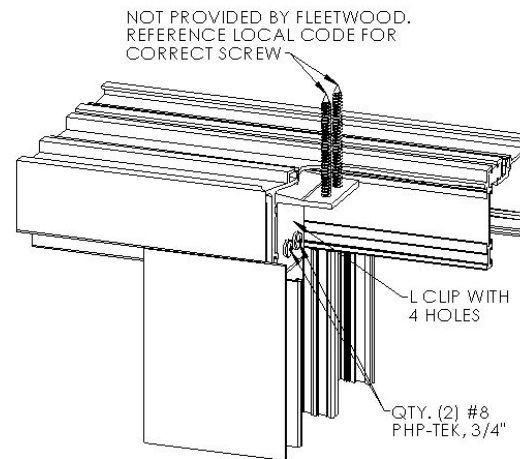

Figure 35:
"L" Bracket at False Jamb / Frame Head

8. Insert screen into the upper head channel. Push up and swing the bottom inward until screen is vertical, then lower screen down onto the track (Figure 36).

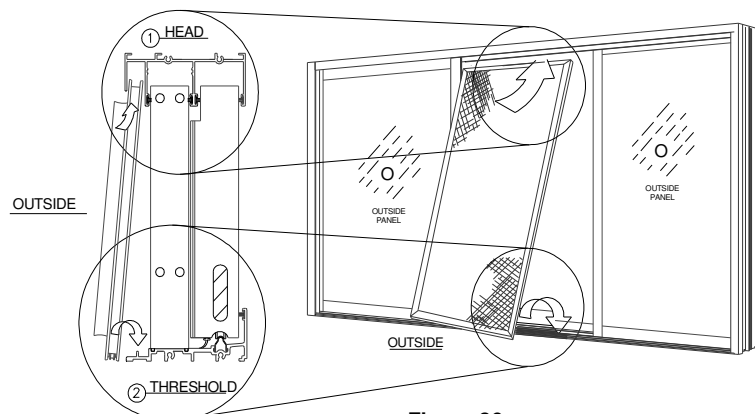

Figure 36:
OXO Screen Installation

XV. Flashing after Installation

The flashing paper referred to in this document is Moistop or other code compliant flashing material that conforms to **Federal Specification UU-B-790a, Type 1, Grade A, Style 4**. The strips of flashing paper are to be no less than 9 inches wide (or wider as required by local codes). Flashing paper must be applied with galvanized nails or corrosion resistant staples. Flashing paper shall be applied in a weatherboard fashion around the full perimeter of the framed opening.

1. Once satisfied that the frame is water tight, and immediately prior to application of the flashing paper at the head and jambs, apply a continuous bead of sealant to the exposed mounting flange (nail-fin) at the top (head) and sides (jambs) of the installed frame. Also, apply sealant at corners of the frame, the full length of the seams where the nail fin flashing is mounted.
2. At each jamb, embed the flashing paper into the sealant onto mounting flange and fasten into place. The flashing paper should be cut sufficiently long enough to extend at least 3 in. past the weep-screed or diado flashing and at least 6 inches above the head of the window (Figure 37).
3. Finally, at the head, embed the flashing into the sealant on the mounting flange and fasten into place. The flashing paper should be cut sufficiently long enough to extend past the flashing paper at each jamb by at least 3 in (Figure 38).
4. Weather resistant building paper should be applied in a weatherboard fashion to complete the installation (Figure 39).

Note: Where weather resistant building paper, insulating board, or other materials by other trades may constitute the primary weather barrier behind the exterior wall finish (i.e. stucco, masonry, siding, etc.), the owner / General Contractor are responsible to ensure that the weather barrier is continuous by effectively sealing the material to the window frame.

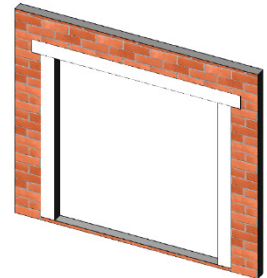

Figure 37:
Jamb flashing

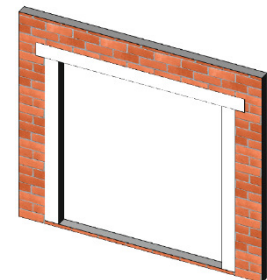

Figure 38:
Head Flashing

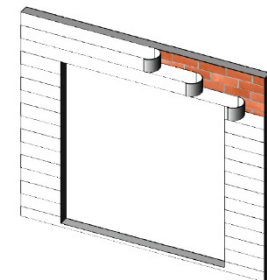

Figure 39:
Building Flashing

Appendix A: Magnetic Latch Instructions

Basic Functions & Features

- Rofu 8406M magnetic lock.
- Automated locking when the door closes
 - The magnet is activated when the power source is connected and on.
- Remote access provided by home automation or user interface (not by Fleetwood)

Provided (located)

- An electromagnets lock that is activated by a 24VDC or 12VDC power supply
- The magnet strike is located above the Archetype Hardware
- Fleetwood provides the Frame and Panel(s) fabricated to assemble the magnet and the magnetic strike into the door
- Wiring for the magnet is accessible from the backside of the active jamb
- The Archetype Narrow hardware is required for added security (i.e. power outages)
 - The magnetic lock should only be considered as a secondary lock, not the primary lock.

Note: The magnetic lock can only be located in the Jamb. Doors that lock with meeting stiles are not offered with magnetic locks.

Not Provided

- Power Supply: 24VDC or 12VDC is required.
- User Interface: Entry access system (e.g., keypad, biometric, etc.). The lock can be integrated with home automation systems or an electronic switch interface.

Retrofitting

- Existing doors would require factory CNC fabrication. At a minimum, a new Locking Jamb and Lead Stile would be required.

Adjustment

- After adjusting the panels, the magnet in the jamb needs to make full contact with the strike located on the panel. Turning the screws (located on the magnet), will allow the magnet to move in and out from the jamb, adjust until the magnet forms a parallel contact with the strike on the panel.

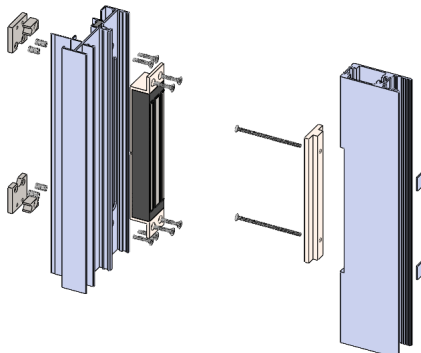

ARCHETYPE

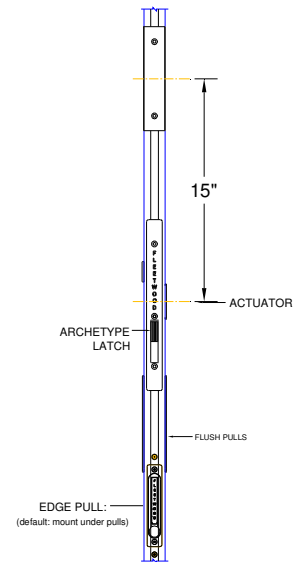

ARCHETYPE NARROW

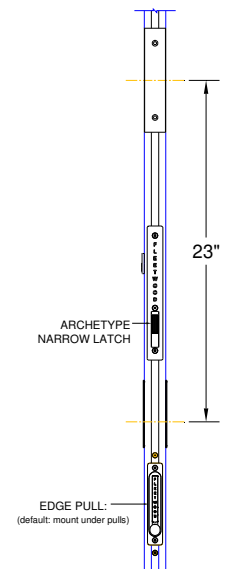

Appendix A cont: Magnetic Latch Instructions

Connecting Diagram

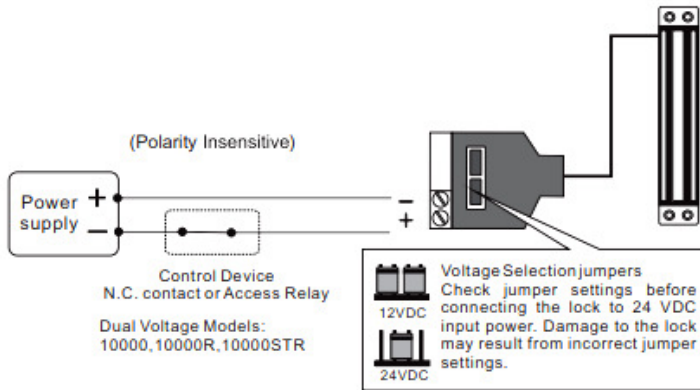

Butt Splice (DC) Connector

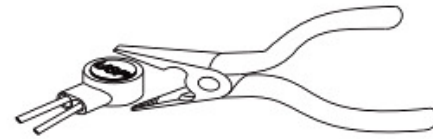

Use crimper or pliers and press the header of connector down to even position

Important Note

	<p>The 8406M requires a face-to-face alignment as shown in the far left figure. This magnet is NOT designed as a Shear Lock.</p>
	<p>Ensure the surface area of the electromagnetic lock and the armature plate mate correctly or you will not get a good bond.</p>
	<p>Ensure the face of the armature plate and magnet are clean. Use a soft cloth to clean the surface. Never use anything abrasive to clean the magnet or armature plate.</p>
	<p>Wipe the surface of magnet lock with anti-rust oil regularly.</p>
	<p>Ensure you notice the + and - although the unit is polarity insensitive.</p>
	<p>Remove any diode installed across the magnetic lock for spike suppression. The magnet is built-in with a metal oxide varistor to prevent back EMF.</p>
	<p>The electromagnetic locks are fail safe. Therefore it needs the power from UPS to remain locked during the power failure.</p>

Appendix B: Thermal Narrow Interlocker Glazing

Tools Required: Structural Sealant (Dow 995), Silicone Gun, Razor knife/blade, Silicone Tooling Device. *See Section II of Installation Instructions for tools required to glaze the door panel.*

Important: Structural Sealant takes on average 14-30 days to fully cure depending on climate. Panels must be glazed square and remain square throughout the curing process to remain square. Once the panels have been wet glazed they must be stored safe from disruption and movement. The panels must be stored where debris will not stick to the silicone before it can skin over. (Approximately 4 hours)

1. Follow the directions of Section V for how to place the glazing vinyl and glaze the top rail, bottom rail, and lead stiles.
2. At the thermal interlock location, on the glazing vinyl, mark the midpoint.
3. From the midpoint, mark 2.5" up and down on the glazing vinyl for a total of 5".
4. Cut out the 5" section of glazing vinyl as shown (Figure B1).
5. Place Structural Sealant at the location where glazing vinyl has been removed.
6. Glaze the Thermal Narrow Interlocker the same as the other components by driving the extrusions onto the glass and glazing vinyl.
7. Place the Narrow Interlocker Spacer (Figure B2) flush at the top of the interlocker in between the top rail and interlocker.
8. Secure the Thermal Narrow Interlocker with provided 2" FHP stainless steel screws.

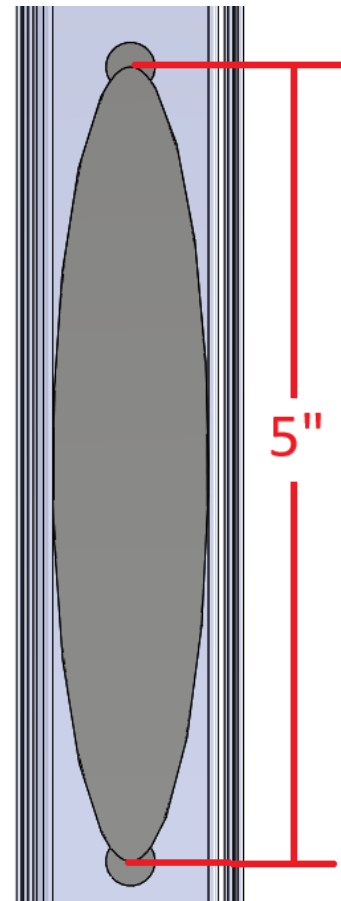

Figure B1:
 Side View, Glazing Vinyl Removal

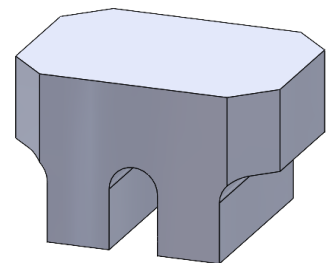

Figure B2:
 Narrow Interlocker Spacer