



Series 3070-HI Sliding Glass Door w/ 60° or 135° Outside Corner "NON-IMPACT"

GENERAL NOTES

1. This product has been evaluated and is in compliance with the 7th Edition (2020) Florida Building Code (FBC) structural requirements excluding the "High Velocity Hurricane Zone" (HVHZ).
2. Product anchors shall be as listed and spaced as shown on details. Anchor embedment to base material shall be beyond wall dressing or stucco.
3. When used in areas requiring wind borne debris protection this product is required to be protected with an impact resistant covering that complies with FBC Sections 1609.1.2 & R301.2.1.2.
4. For 2x stud framing construction, anchoring of these units shall be the same as that shown for 2x buck masonry construction.
5. Site conditions that deviate from the details of this drawing require further engineering analysis by a licensed engineer or registered architect.

TABLE OF CONTENTS	
SHEET#	DESCRIPTION
1	Typical elevations, design pressures and general notes
2	Horizontal cross sections
3	Horizontal cross sections
4	Vertical cross sections
5	Buck anchoring
6	Frame anchoring
7	Components
8	Bill of materials and glazing details

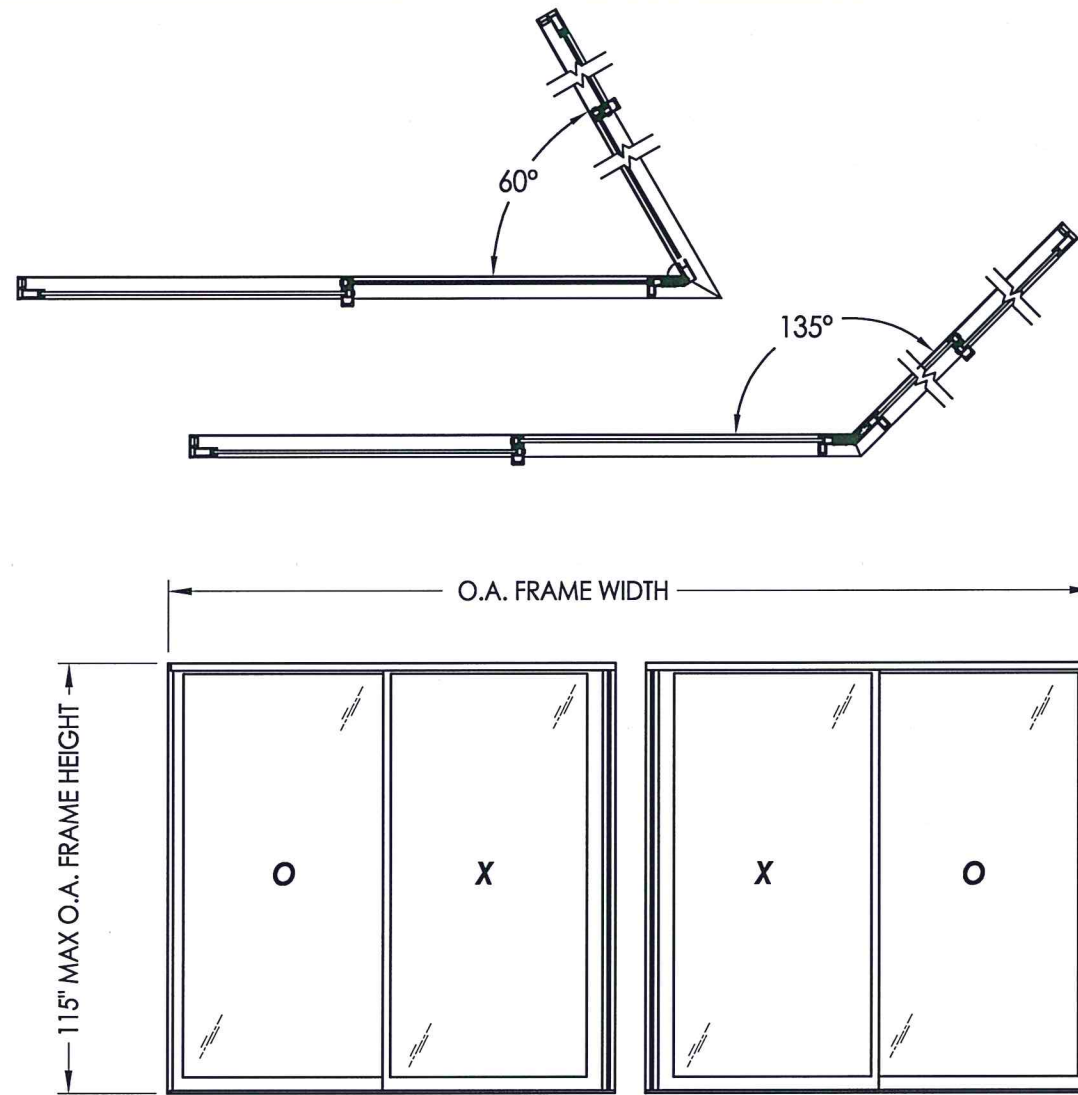

CORNER	MAX PANEL DIMENSION	MAX D.L.O. DIMENSION	GLASS TYPE	DESIGN PRESSURE (PSF)	
				POSITIVE	NEGATIVE
60°	60.75" X 98.25"	52.63" X 91.5"	G1	+55.0	-55.0
	51.12" X 113.25"	43.0" X 106.5"	G1	+55.0	-55.0
135°	60.75" X 98.25"	52.63" X 91.5"	G1	+53.3	-53.3
	51.12" X 113.25"	43.0" X 106.5"	G1	+53.3	-53.3

Note: 2 + 2 Panels shown, however, any combination of fixed and operable panels is allowed. There is not a limit on the number of panels.

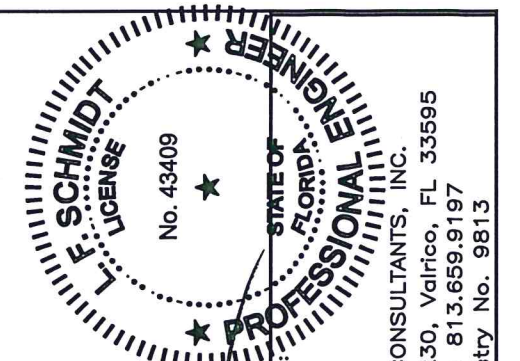

August 10, 2020
 Documents Prepared By:
 Lyndon F. Schmidt
 P.E. No. 43409

R.W. BUILDING CONSULTANTS, INC.
 P.O. Box 230, Valrico, FL 33595
 Phone No.: 813.659.9197
 FBPE Registry No. 9813

PRODUCT:	FLEETWOOD WINDOWS & DOORS
PART OR ASSEMBLY:	TYPICAL ELEVATION, DESIGN PRESSURES & GENERAL NOTES
DATE:	3/20/14
SCALE:	N.T.S.
DWG. BY:	JK
CHK. BY:	LFS
DRAWING NO.:	FL-15560.10
SHEET	1 OF 8

\\dc01\rbwbc\Clients\Fleetwood PERMANENTVA - Florida Product Approvals\FL-15560 (2020)\FL-15560 Sliding Patio Doors\C - Drawings\FL 15560 (2020)\FL-15560.8 - 10.dwg

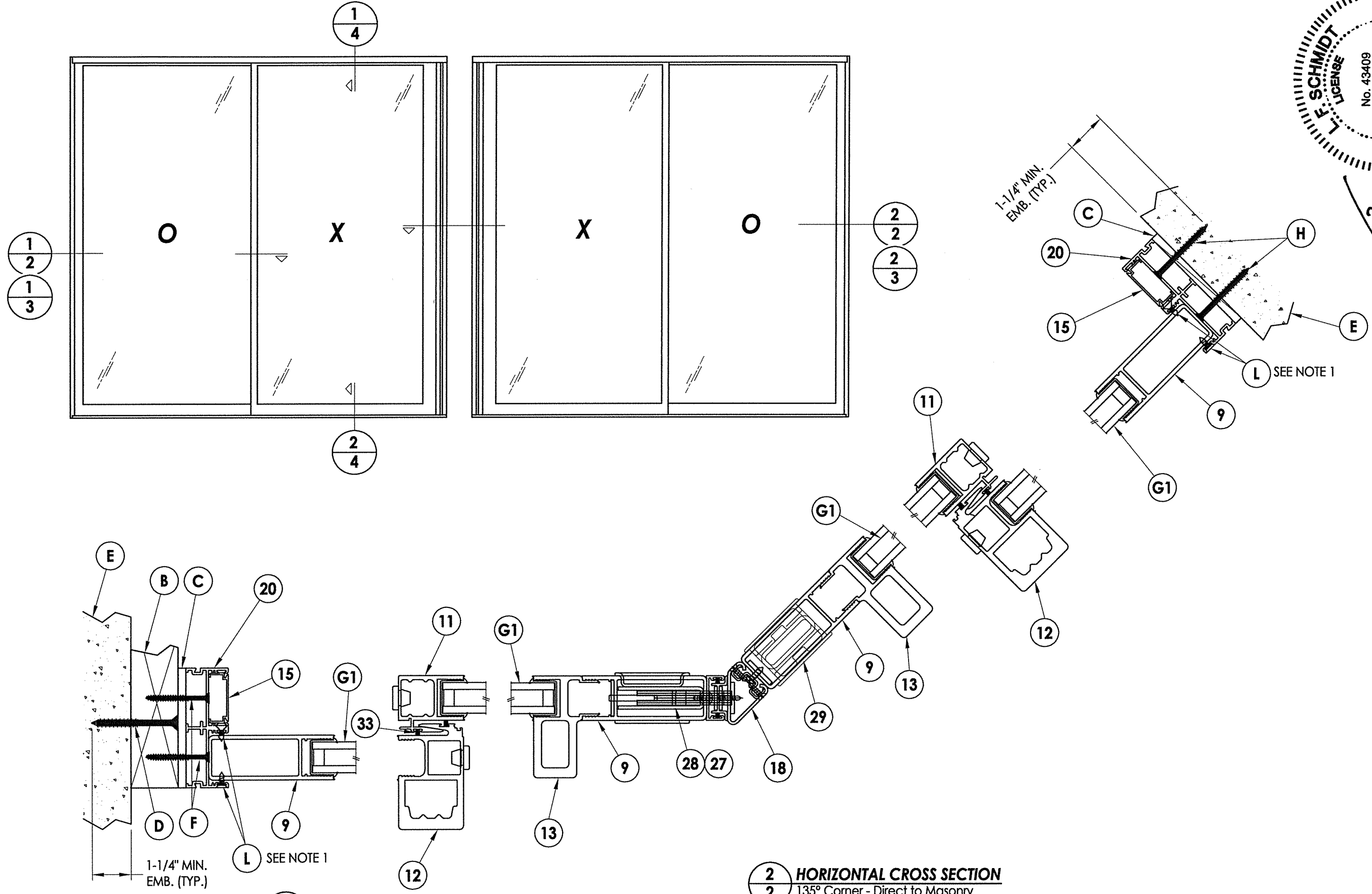

NOTE:
1. Fixed panel screws located 39" from each end.

1 HORIZONTAL CROSS SECTION
2X Buck Construction

2 HORIZONTAL CROSS SECTION
135° Corner - Direct to Masonry

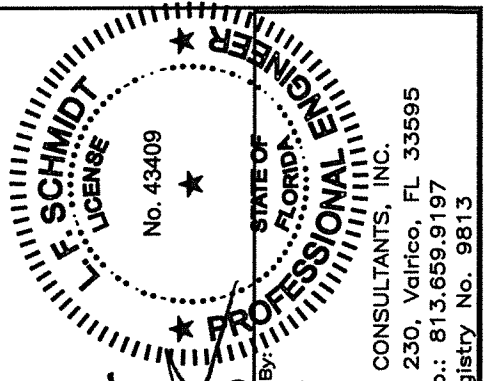

August 10, 2020
Documents Prepared By:
Lyndon F. Schmidt
P.E. No. 43409
RW
BUILDING CONSULTANTS, INC.
P.O. Box 230, Valrico, FL 33595
Phone No.: 813.659.9197
FBPE Registry No. 9813

PRODUCT:
FLEETWOOD WINDOWS & DOORS
PART OR ASSEMBLY:
HORIZONTAL CROSS SECTIONS

NO.	DATE	REVISIONS
4	8/10/20	UPDATE TO 7th ED. (2020) FBC DAC
3	08/08/17	UPDATE TO 6TH ED. (2017) FBC LFS
2	8/06/15	CLARIFY MAX PANEL SIZE & CHANGE NAME JK
1	04/22/15	UPDATE TO 5TH ED. (2014) FBC JK
		BY

DATE: 3/20/14
SCALE: N.T.S.
DWG. BY: JK
CHK. BY: LFS
DRAWING NO.: FL-15560.10
SHEET 2 OF 8

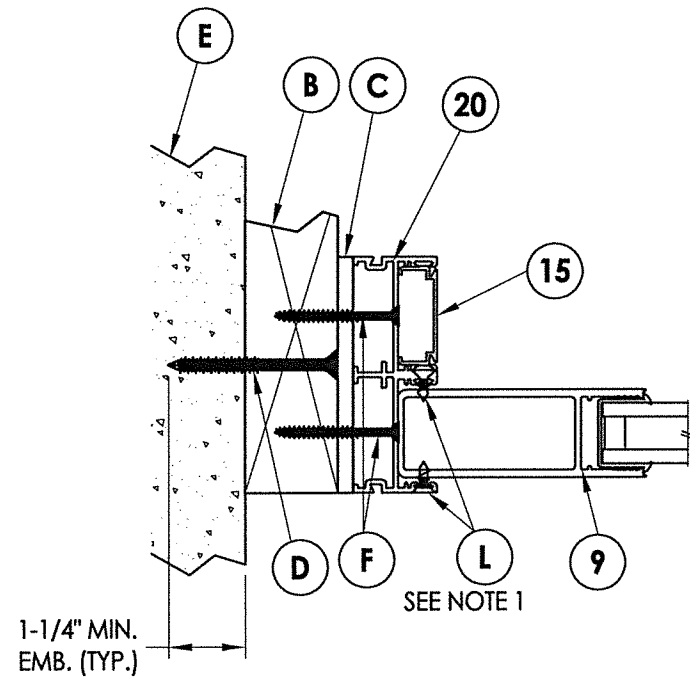

1 HORIZONTAL CROSS SECTION
3 2X Buck Construction

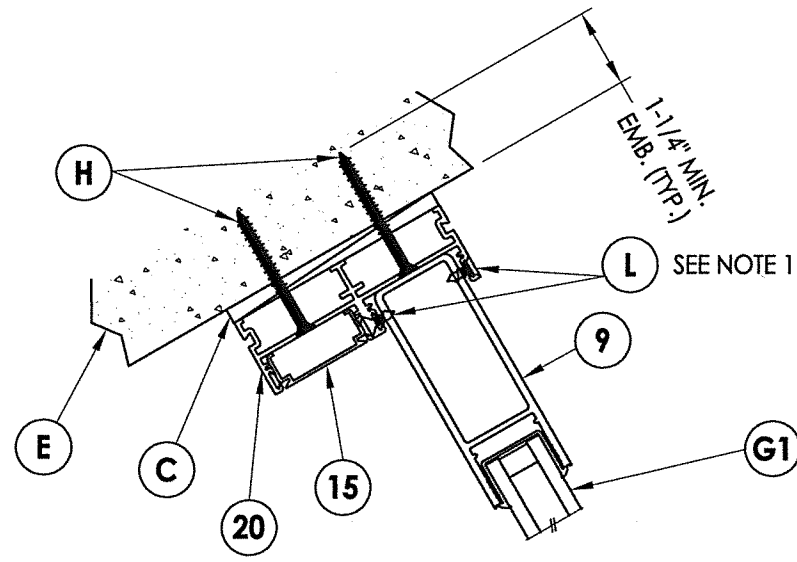

2 HORIZONTAL CROSS SECTION
3 60° Corner - Direct to Masonry

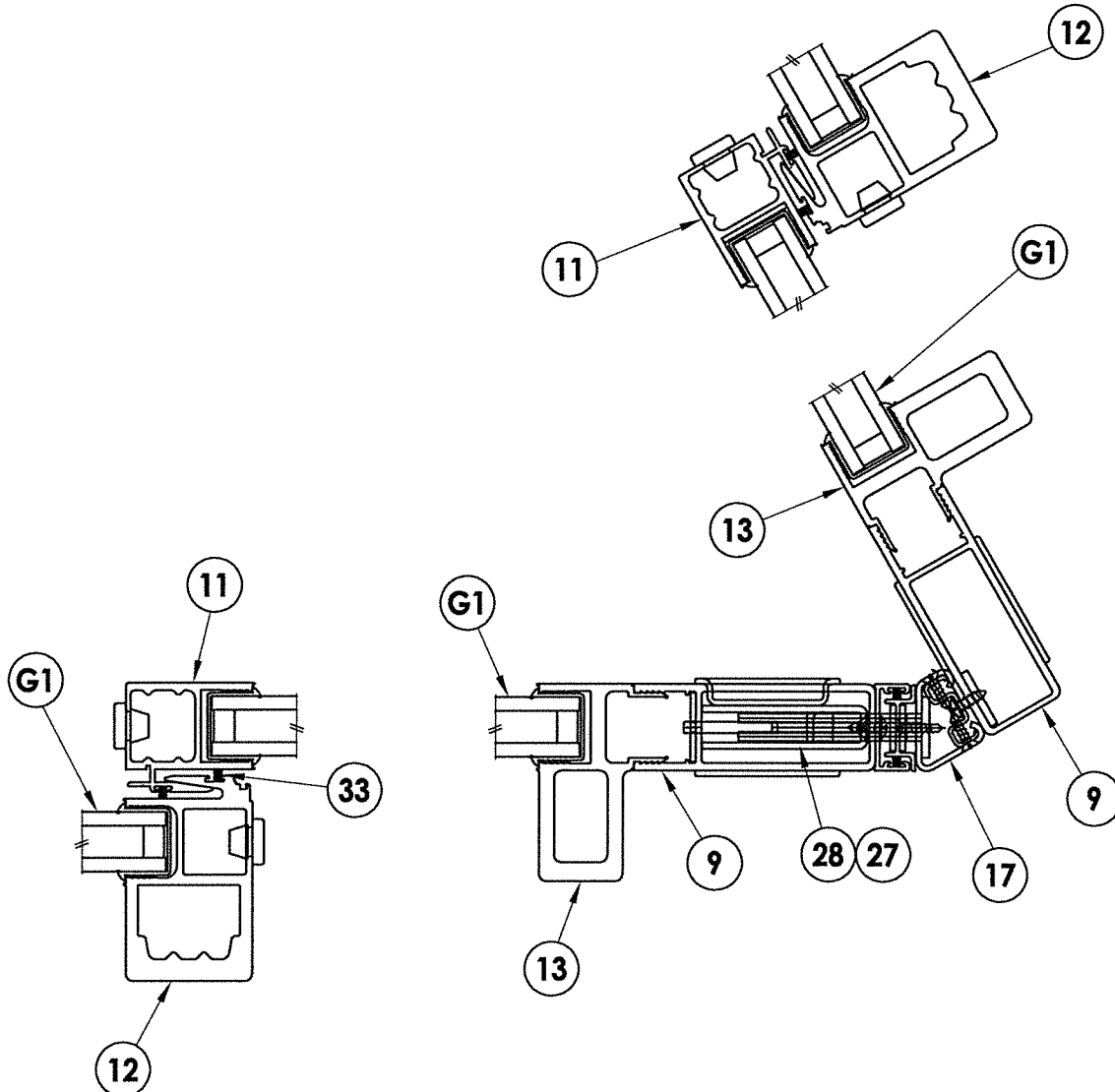

NOTE:
 1. Fixed panel screws located 39" from each end.

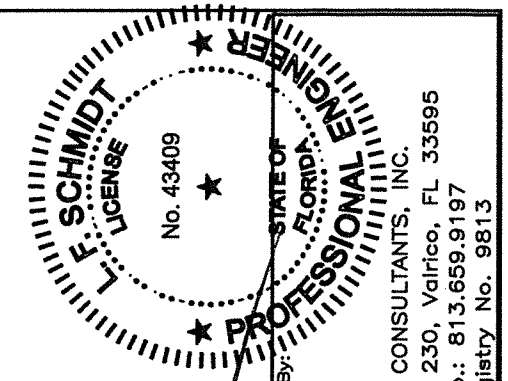

August 10, 2020
 Documents Prepared By:
 Lyndon F. Schmidt
 P.E. No. 43409
 RW BUILDING CONSULTANTS, INC.
 P.O. Box 230, Valrico, FL 33595
 Phone No.: 813.659.9197
 FBPE Registry No. 9813

PRODUCT:		FLEETWOOD WINDOWS & DOORS	
PART OR ASSEMBLY:		HORIZONTAL CROSS SECTIONS	
NO.	DATE	REVISIONS	BY
4	8/10/20	UPDATE TO 7th ED. (2020) FBC	DAC
3	08/08/17	UPDATE TO 6TH ED. (2017) FBC	LFS
2	8/06/15	CLARIFY MAX PANEL SIZE & CHANGE NAME	JK
1	04/22/15	UPDATE TO 5TH ED. (2014) FBC	JK

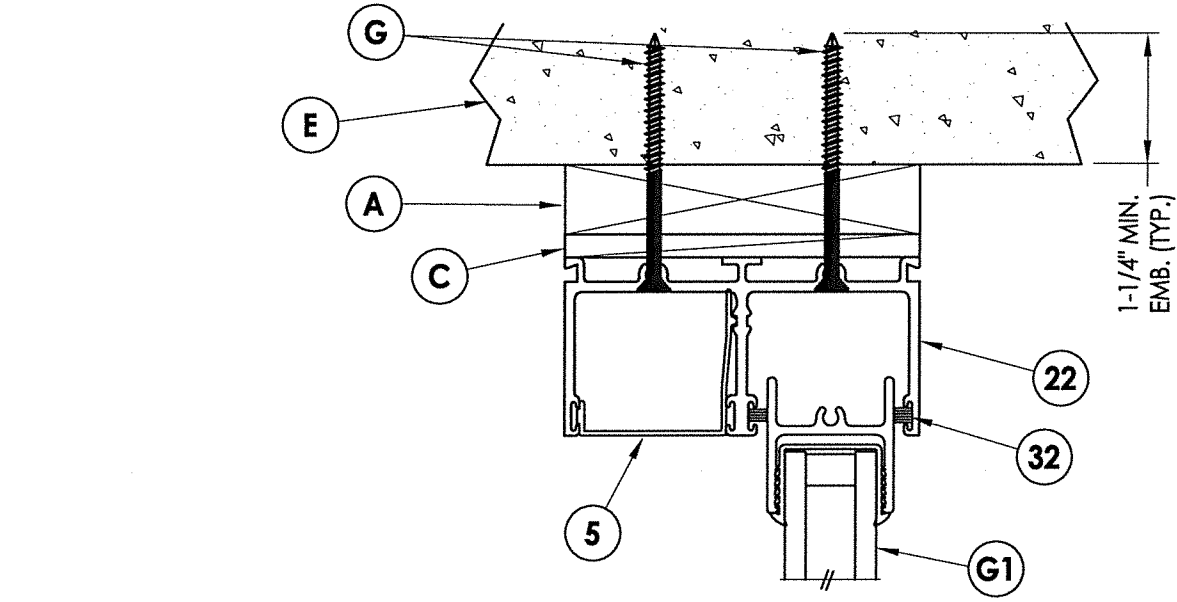

1 VERTICAL CROSS SECTION
4 1X Buck Construction

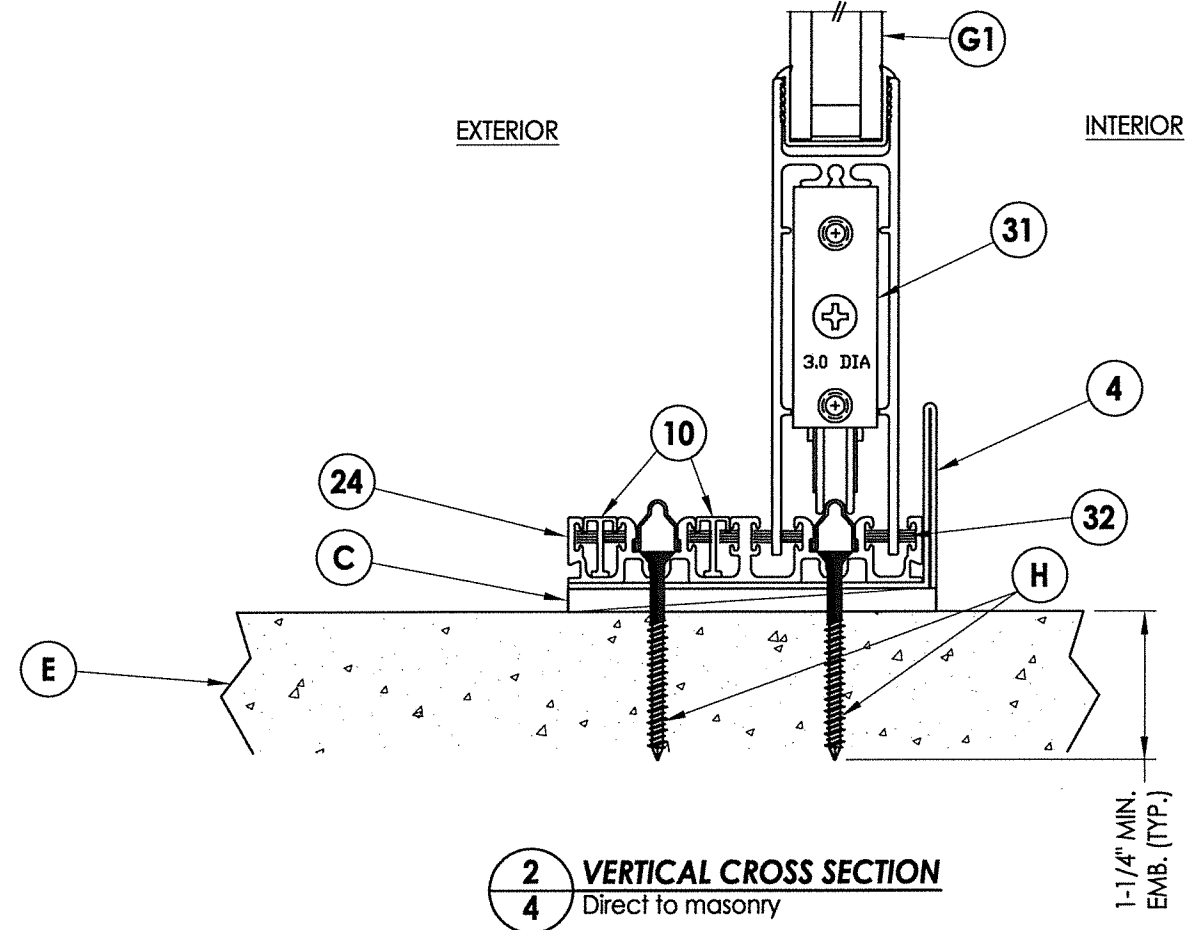

2 VERTICAL CROSS SECTION
4 Direct to masonry

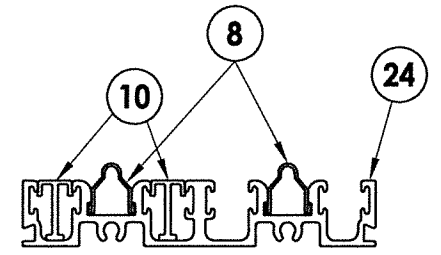
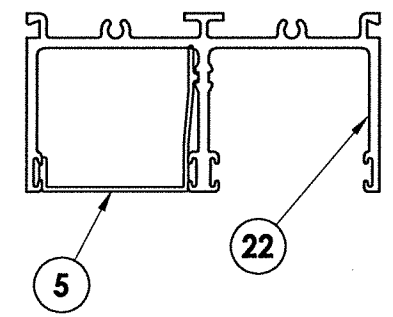

HEAD & SILL COVER CONDITION

NOTE:
1. A full-depth cut-out (1" wide x 3/16" tall) in track base is necessary to allow for water drainage (12" from each end and 24" o.c.).

August 10, 2020
 Documents Prepared By: Lyndon F. Schmidt
 P.E. No. 43409
 R.W. BUILDING CONSULTANTS, INC.
 P.O. Box 230, Valrico, FL 33595
 Phone No.: 813.659.9197
 FBPE Registry No. 9813

PRODUCT:		FLEETWOOD WINDOWS & DOORS			
PART OR ASSEMBLY:		VERTICAL CROSS SECTIONS			
NO.	DATE	REVISIONS	BY	JK	JK
4	8/10/20	UPDATE TO 7th ED.(2020)	FBC	DAC	
3	08/08/17	UPDATE TO 6TH ED. (2017)	FBC	LFS	
2	8/06/15	CLARIFY MAX PANEL SIZE & CHANGE NAME		JK	
1	04/22/15	UPDATE TO 5TH ED. (2014)	FBC	JK	

DATE:	3/20/14
SCALE:	N.T.S.
DWG. BY:	JK
CHK. BY:	LFS
DRAWING NO.:	FL-15560.10
SHEET	4 OF 8

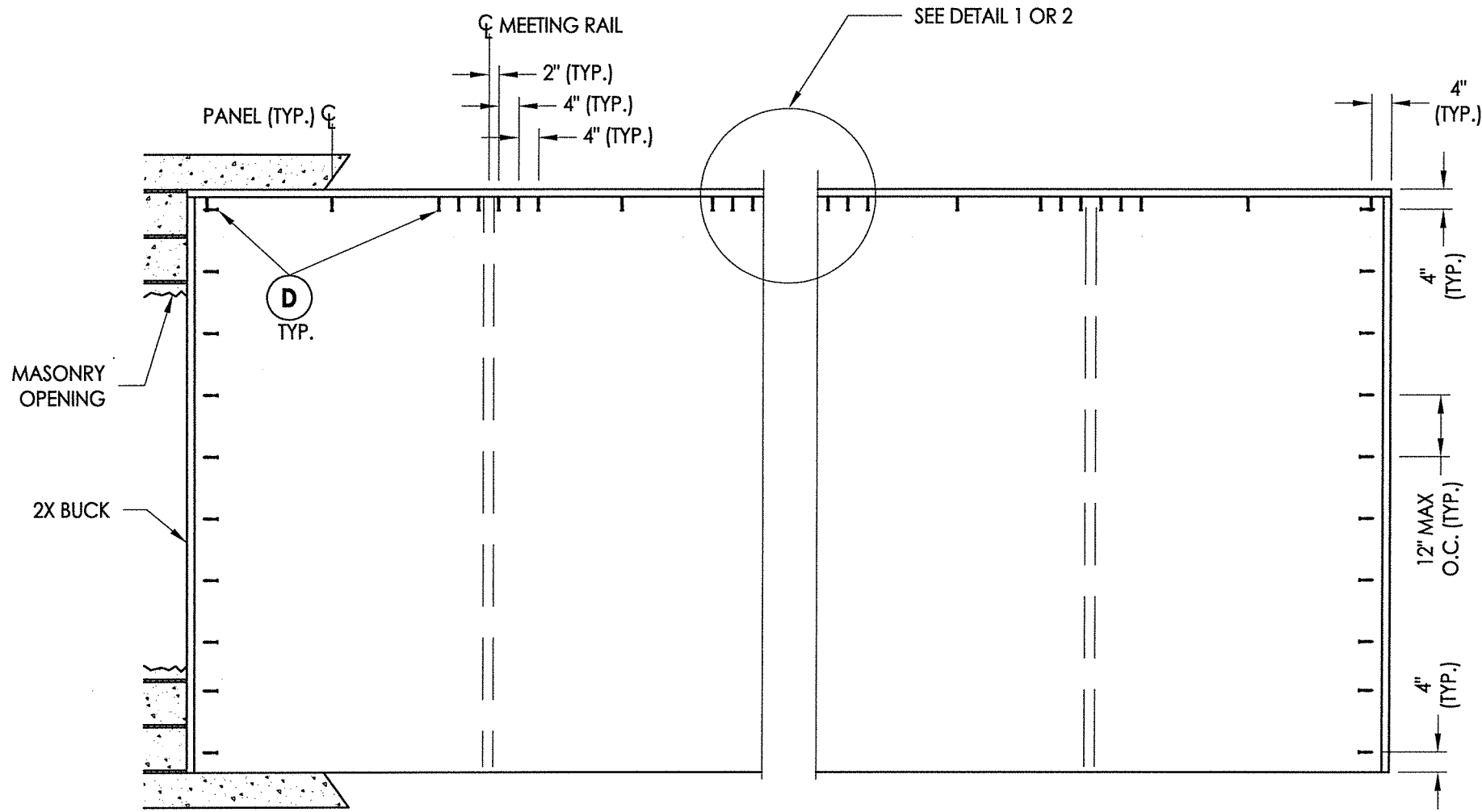

2X BUCK ANCHORING

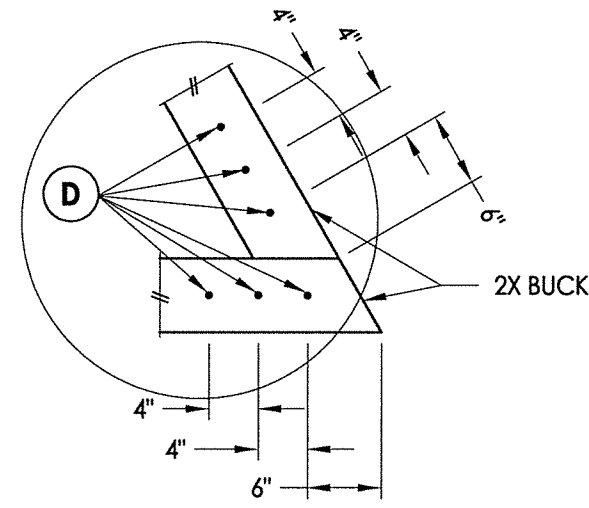
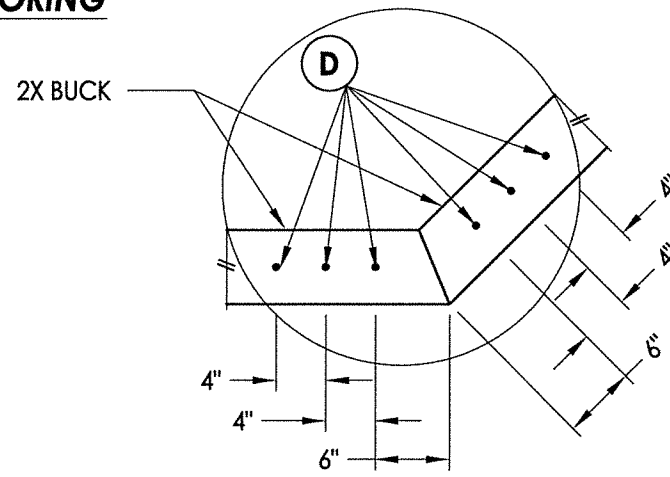

CONCRETE ANCHOR NOTES:

- Concrete anchor locations at the corners may be adjusted to maintain the min. edge distance to mortar joints.
- Concrete anchor locations noted as "MAX. ON CENTER" must be adjusted to maintain the min. edge distance to mortar joints, additional concrete anchors may be required to ensure the "MAX. ON CENTER" dimension are not exceeded.
- Concrete anchor table:

ANCHOR TYPE	ANCHOR SIZE	MIN. EMBEDMENT	MIN. CLEARANCE TO MASONRY EDGE	MIN. CLEARANCE TO ADJACENT ANCHOR
ITW TAPCON®	1/4"	1-1/4"	2"	4"
DeWALT ULTRACON+	1/4"	1-1/4"	2-1/2"	4"

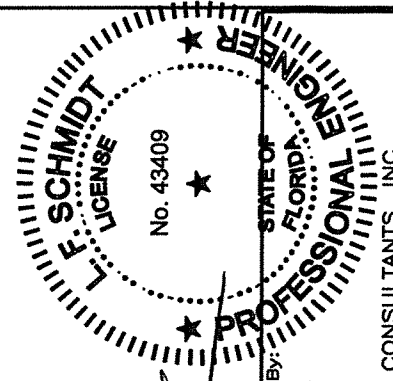

August 10, 2020
 Documents Prepared By:
 Lyndon F. Schmidt
 P.E. No. 43409
 RW BUILDING CONSULTANTS, INC.
 P.O. Box 230, Vairco, FL 33595
 Phone No.: 813.659.9197
 FBPE Registry No. 9813

PRODUCT:
 FLEETWOOD WINDOWS & DOORS
 PART OR ASSEMBLY:
 BUCK ANCHORING

NO.	DATE	REVISIONS
4	8/10/20	UPDATE TO 7TH ED. (2020) FBC
3	08/08/17	UPDATE TO 6TH ED. (2017) FBC
2	8/06/15	CLARIFY MAX PANEL SIZE & CHANGE NAME
1	04/22/15	UPDATE TO 5TH ED. (2014) FBC

DATE: 3/20/14
 SCALE: N.T.S.
 DWG. BY: JK
 CHK. BY: LFS
 DRAWING NO.: FL-15560.10
 SHEET 5 OF 8

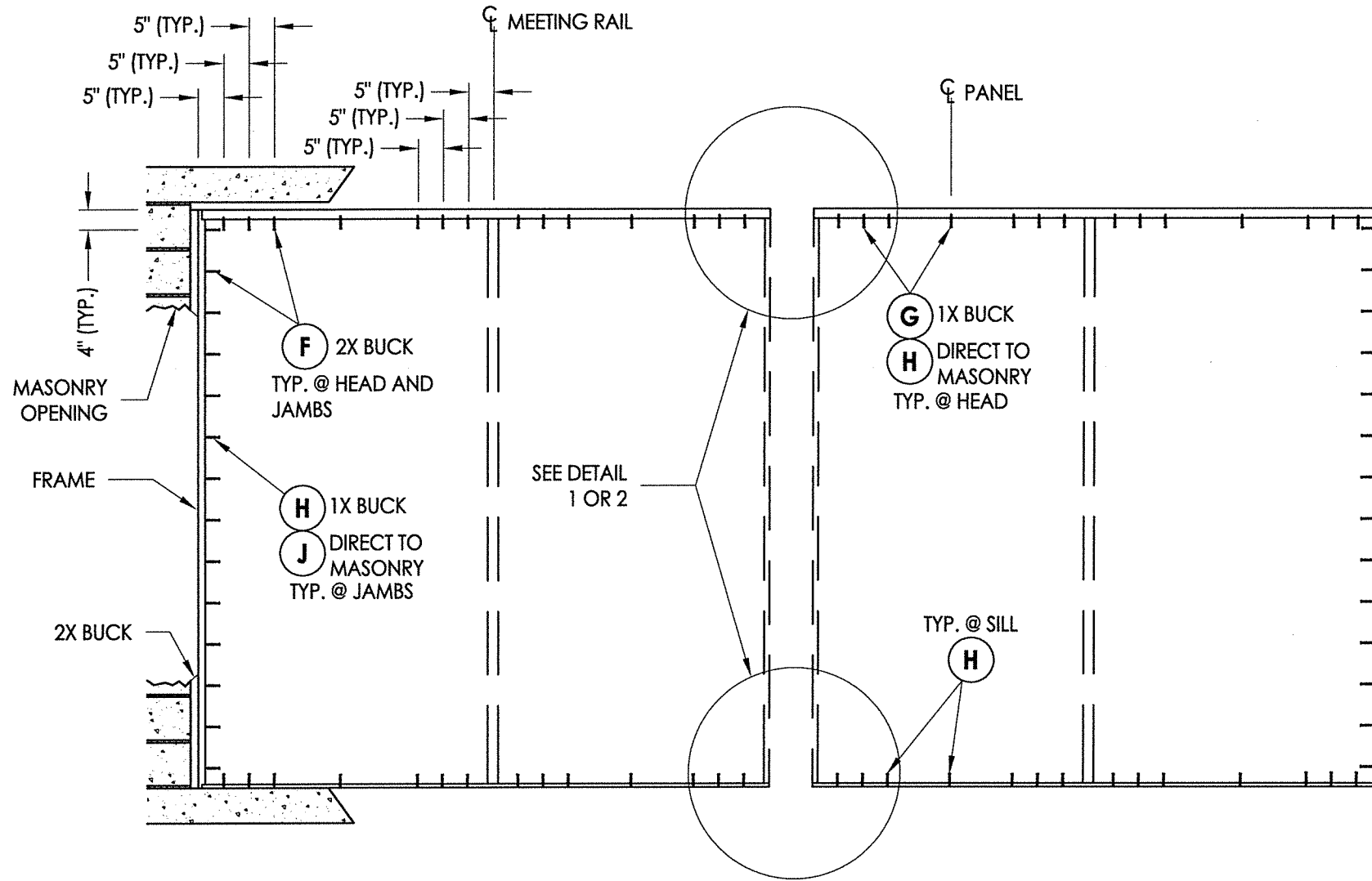

FRAME ANCHORING

(NOTE: 1 ANCHOR REQUIRED PER EACH TRACK RUN @ EACH LOCATION)

CONCRETE ANCHOR NOTES:

- Concrete anchor locations at the corners may be adjusted to maintain the min. edge distance to mortar joints.
- Concrete anchor locations noted as "MAX. ON CENTER" must be adjusted to maintain the min. edge distance to mortar joints, additional concrete anchors may be required to ensure the "MAX. ON CENTER" dimension are not exceeded.
- Concrete anchor table:

ANCHOR TYPE	ANCHOR SIZE	MIN. EMBEDMENT	MIN. CLEARANCE TO MASONRY EDGE	MIN. CLEARANCE TO ADJACENT ANCHOR
ITW TAPCON®	3/16"	1-1/4"	2"	1-7/8"

WOOD SCREW INSTALLATION NOTES:

- Maintain a minimum 3/4" edge distance, 1" end distance, & 1" o.c. spacing of wood screws to prevent the splitting of wood.

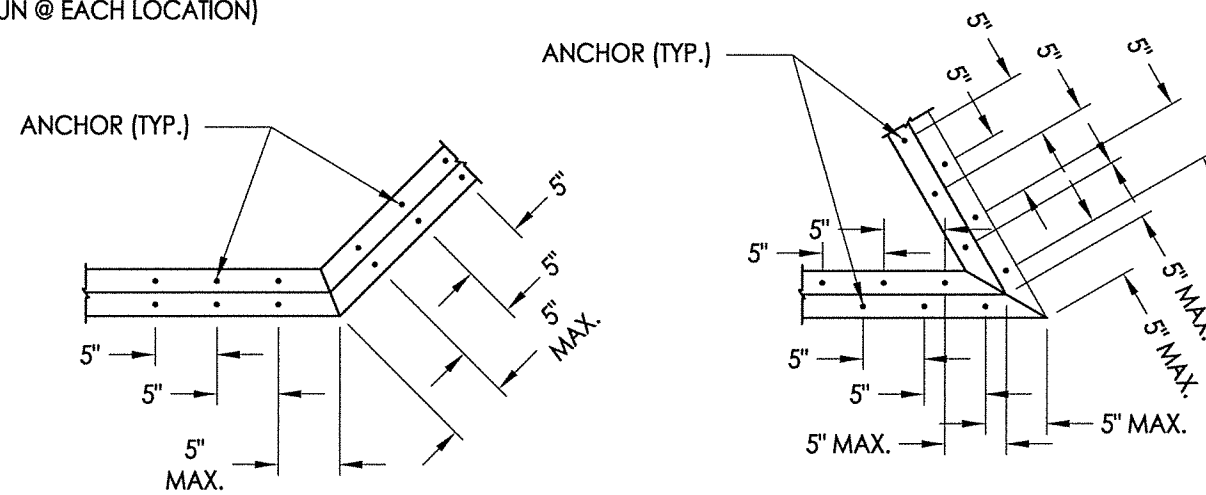

DETAIL 1
135° Corner

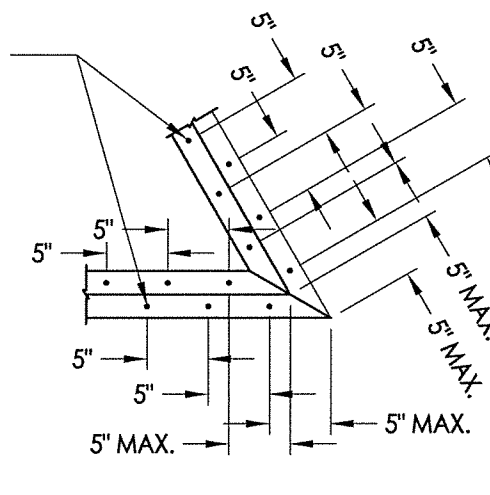

DETAIL 2
60° Corner

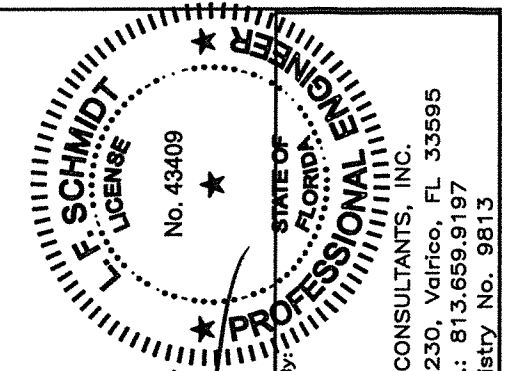

August 10, 2020
 Documents Prepared By:
 Lyndon F. Schmidt
 P.E. No. 43409
 R.W. BUILDING CONSULTANTS, INC.
 P.O. Box 230, Valrico, FL 33595
 Phone No.: 813.659.9197
 FBPE Registry No. 9813

PRODUCT:		FLEETWOOD WINDOWS & DOORS	
PART OR ASSEMBLY:		FRAME ANCHORING	
NO.	DATE	REVISIONS	
4	8/10/20	UPDATE TO 7TH ED. (2020) FBC	DAC
3	08/08/17	UPDATE TO 6TH ED. (2017) FBC	LFS
2	8/06/15	CLARIFY MAX PANEL SIZE & CHANGE NAME	JK
1	04/22/15	UPDATE TO 5TH ED. (2014) FBC	JK
			BY

DATE: 3/20/14
 SCALE: N.T.S.
 DWG. BY: JK
 CHK. BY: LFS
 DRAWING NO.: FL-15560.10
 SHEET 6 OF 8

\\dc01\rbw\clients\Fleetwood PERMANENTA - Florida Product Approvals\FL-15560 Sliding Patio Doors\C - Drawings\FL 15560 (2020)\FL-15560.8-10.dwg

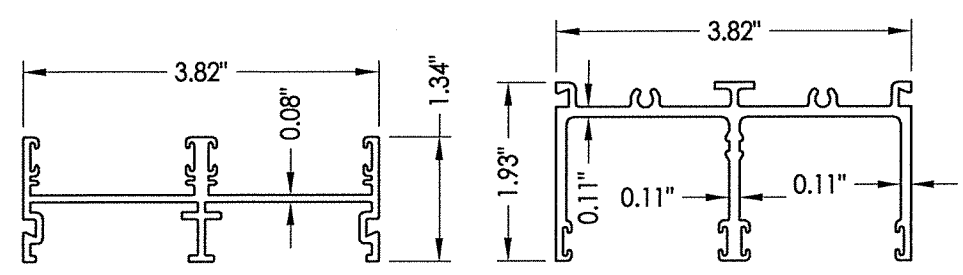

20 JAMB TRACK
2 Runs

22 HEAD TRACK
2 Runs

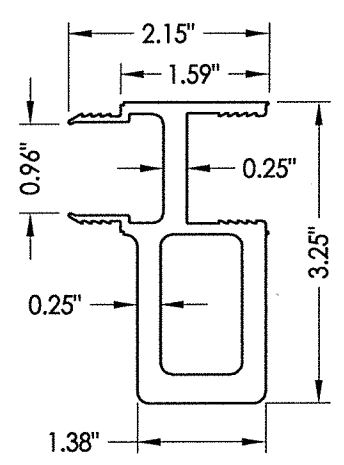

13 WINDLOAD ADAPTER

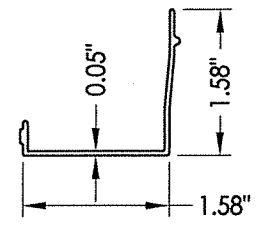

5 HEAD CHANNEL FILLER

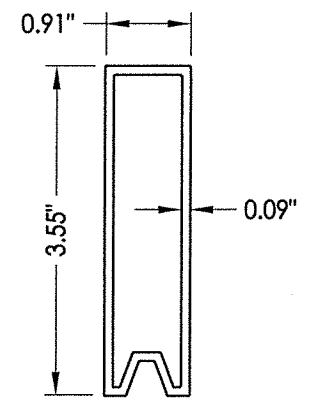

30 PANEL SETTING BLOCK

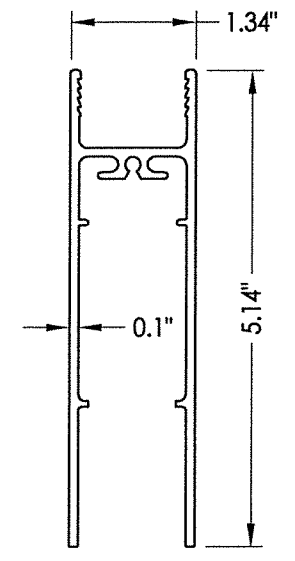

7 BOTTOM RAIL

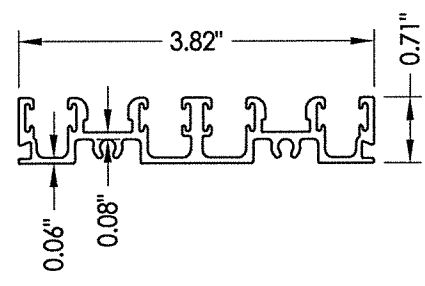

2 SILL TRACK
2 Runs

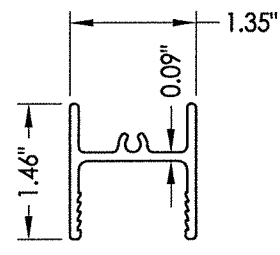

6 TOP RAIL

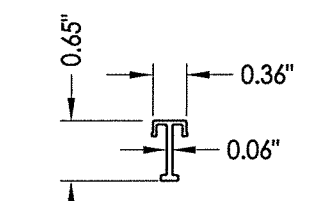

10 SILL CHANNEL FILLER

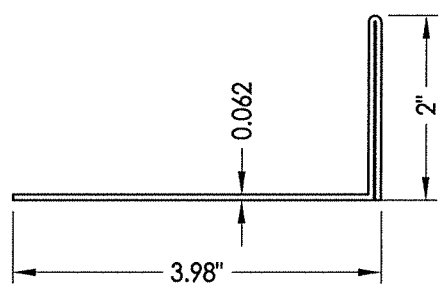

4 SILL PAN

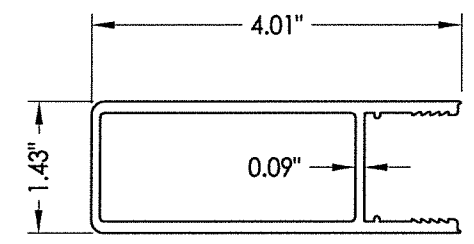

9 STILE

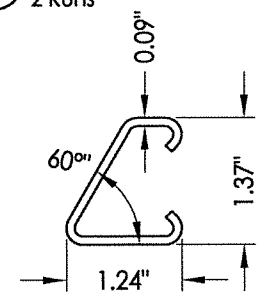

17 60° YOKE

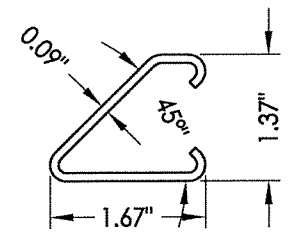

18 135° YOKE

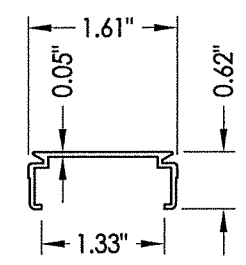

15 JAMB CHANNEL FILLER

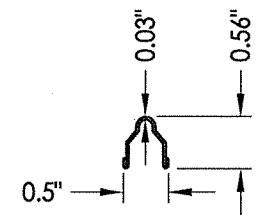

8 TRACK

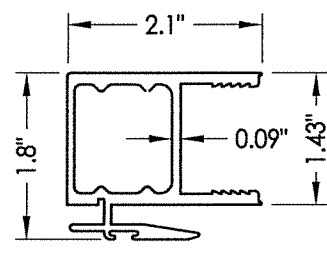

11 INTERLOCK STILE
Standard

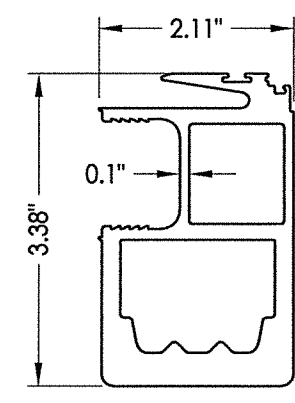

12 INTERLOCK STILE
High Performance

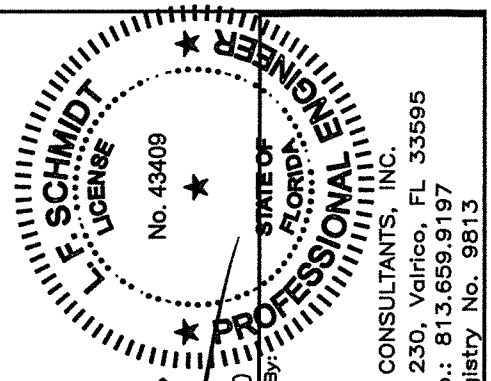

August 10, 2020
 Documents Prepared By:
 Lyndon F. Schmidt
 P.E. No. 43409
 R.W. BUILDING CONSULTANTS, INC.
 P.O. Box 230, Valrico, FL 33596
 Phone No.: 813.659.9197
 FBPE Registry No. 9813

PRODUCT:
 FLEETWOOD WINDOWS & DOORS
 PART OR ASSEMBLY:
 COMPONENTS

NO.	DATE	CHANGE NAME	REVISIONS
4	8/10/20	UPDATE TO 7th ED.(2020) FBC	DAC
3	08/08/17	UPDATE TO 6TH ED. (2017) FBC	LFS
2	8/06/15	CLARIFY MAX PANEL SIZE &	JK
1	04/22/15	UPDATE TO 5TH ED. (2014) FBC	JK

DATE: 3/20/14
 SCALE: N.T.S.
 DWG. BY: JK
 CHK. BY: LFS
 DRAWING NO.: FL-15560.10
 SHEET 7 OF 8

\\dc01\rbw\clients\Fleetwood PERMANENTA - Florida Product Approvals\FL-15560 Sliding Patio Doors\C - Drawings\FL 15560 (2020)\FL-15560.8-.10.dwg

BILL OF MATERIALS		
ITEM #	DESCRIPTION	MATERIAL
A	1X BUCK SG >= 0.55	WOOD
B	2X BUCK SG >= 0.55	WOOD
C	1/4" MAX. SHIM SPACE	-
D	1/4" X 2-3/4" DeWALT OR ITW PFH CONCRETE SCREW	STEEL
E	MASONRY - 3,000 PSI MIN. CONCRETE CONFORMING TO ACI 301 OR HOLLOW BLOCK CONFORMING TO ASTM C90	CONCRETE
F	#10 X 2" PFH SMS (1" MIN. EMBEDMENT)	STEEL
G	3/16" X 2-3/4" ITW PFH CONCRETE SCREW	STEEL
H	3/16" X 2-1/4" ITW PFH CONCRETE SCREW	STEEL
J	3/16" X 3-1/4" ITW PFH CONCRETE SCREW	STEEL
K	1/4" X 1- 3/4" DeWALT PFH CONCRETE SCREW	STEEL
L	#8 X 1/2" PFH SMS	STEEL
4	SILL PAN (2 RUNS)	5052 -ALUM
5	HEAD CHANNEL FILLER	6063-T6 ALUM
6	TOP RAIL	6063-T6 ALUM
7	BOTTOM RAIL	6063-T6 ALUM
8	TRACK	S.S.
9	STILE	6063-T6 ALUM
10	SILL CHANNEL FILLER	6063-T6 ALUM
11	STANDARD INTERLOCK STILE	6063-T6 ALUM
12	HIGH PERFORMANCE INTERLOCK STILE	6063-T6 ALUM
13	WINDLOAD ADAPTER	6063-T6 ALUM
15	JAMB CHANNEL FILLER	6063-T6 ALUM
17	60° YOKE	6063-T6 ALUM
18	135° YOKE	6063-T6 ALUM
20	JAMB TRACK (2 RUNS)	6063-T6 ALUM
22	HEAD TRACK (2 RUNS)	6063-T6 ALUM
24	SILL TRACK (2 RUNS)	6063-T6 ALUM
26	#8 X 3/4" PPH SMS	STEEL
27	PRIMARY LATCH	-
28	SECONDARY LATCH	-
29	HANDLE SET	-
30	PANEL SETTING BLOCK	6063-T6 ALUM
31	MAMMOTH ROLLER ASSEMBLY	-
32	CENTER-FIN WEATHERSEAL .290 HIGH PILE (AMESBURY 43629-270)	-
33	HEAVY DENSITY WEATHERSEAL .300 HIGH PILE (AMESBURY 413330-270)	-

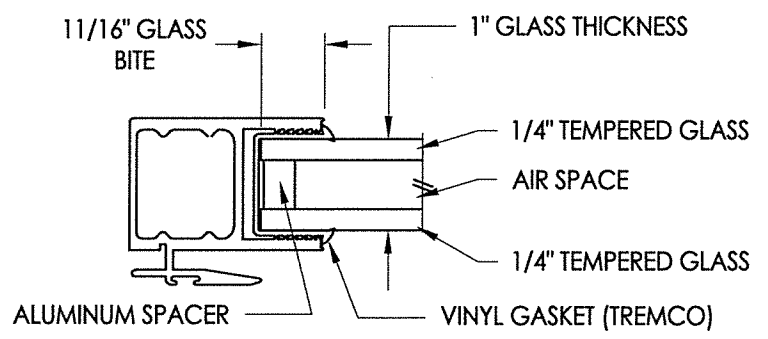

G1 GLAZING DETAIL
Dry Seal

August 10, 2020
 Documents Prepared By:
 Lyndon F. Schmidt
 P.E. No. 43409

RW BUILDING CONSULTANTS, INC.
 P.O. Box 230, Valrico, FL 33595
 Phone No.: 813.659.9197
 FBPE Registry No. 9813

PRODUCT:
 FLEETWOOD WINDOWS & DOORS
 PART OR ASSEMBLY:
 BILL OF MATERIALS
 AND GLAZING DETAILS

NO.	DATE	CHANGE NAME	BY
4	8/10/20	UPDATE TO 7th ED.(2020) FBC	DAC
3	08/08/17	UPDATE TO 6TH ED. (2017) FBC	LFS
2	8/08/15	CLARIFY MAX PANEL SIZE &	JK
1	04/22/15	UPDATE TO 5TH ED. (2014) FBC	JK

REVISIONS

DATE: 3/20/14
 SCALE: N.T.S.
 DWG. BY: JK
 CHK. BY: LFS
 DRAWING NO.:
 FL-15560.10
 SHEET 8 OF 8