

ASSEMBLY / PARTS LIST (B.O.M.)

Series: EDGE | s |
Type: OX Staggered Tracks Configuration

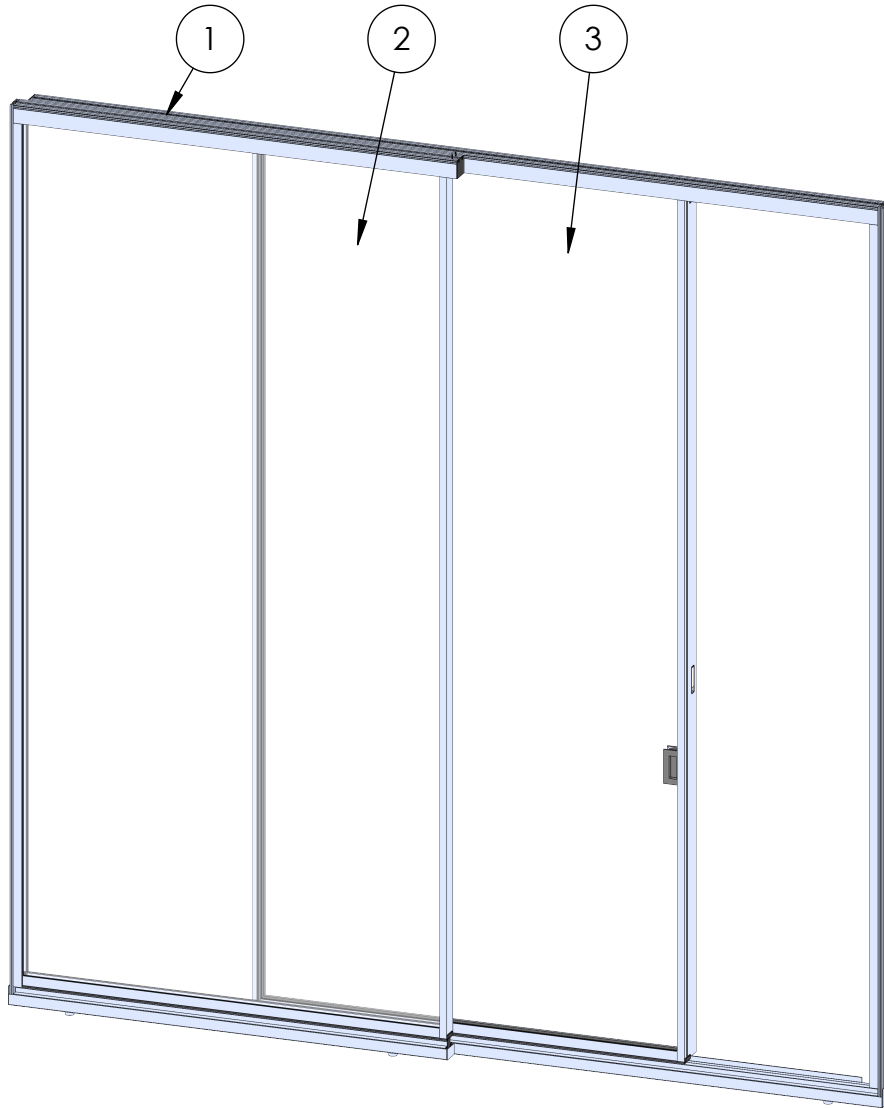

ITEM NO.	DESCRIPTION	QTY.	PAGE #
1	FRAME ASSEMBLY	1	2-3
2	O - PANEL ASSEMBLY	1	4
3	X - PANEL ASSEMBLY	1	5-6

Description Table of Contents	
File Name EDGE _s_OX Assembly	REV B
Released 3/30/2026	SHEET 1 OF 6

PROPRIETARY AND CONFIDENTIAL
 THE INFORMATION CONTAINED IN THIS DRAWING IS THE SOLE PROPERTY OF FLEETWOOD WINDOWS & DOORS.
 ANY REPRODUCTION IN PART OR AS A WHOLE WITHOUT THE WRITTEN PERMISSION OF FLEETWOOD WINDOWS & DOORS IS PROHIBITED.

ASSEMBLY / PARTS LIST (B.O.M.)

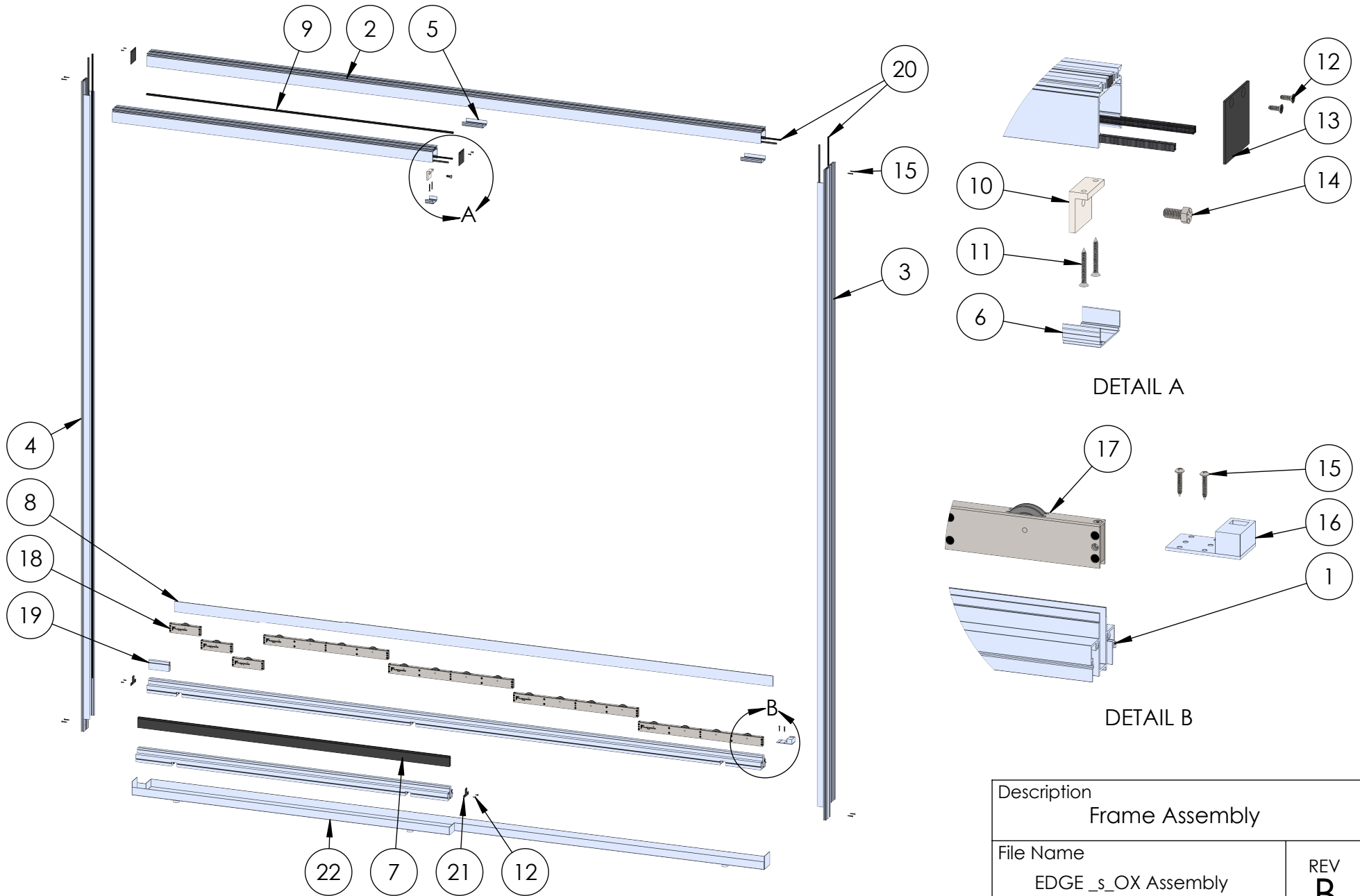

PROPRIETARY AND CONFIDENTIAL
 THE INFORMATION CONTAINED IN THIS DRAWING IS THE SOLE PROPERTY OF FLEETWOOD WINDOWS & DOORS.
 ANY REPRODUCTION IN PART OR AS A WHOLE WITHOUT THE WRITTEN PERMISSION OF FLEETWOOD WINDOWS & DOORS IS PROHIBITED.

Description Frame Assembly	
File Name EDGE _s_OX Assembly	REV B
Released 3/30/2026	SHEET 2 OF 6

ASSEMBLY / PARTS LIST (B.O.M.)

EXTRUSIONS

ITEM NO.	PART NUMBER	DESCRIPTION	QTY.
1	Es0003	Sill	2
2	Es0004	Head	2
3	Es0005	Fin Jamb	1
4	Es0016	Jamb	1
5	Es0013	Anti-Lift	2
6	Es0013	Head filler	1
7	Es0019	Roller Block	1
8	FW1201	Aluminum Flat Bar Slot Drain Spacer	1
HARDWARE			
9	25065	14.6mm x 10.2mm I-Strut	1
10	27018	Fixed Panel Bracket	1
11	20295	#10 FHP-A, 1-1/2", SS, Clear	2
12	20273	#10 FHP-B-UC, 1/2", SS, Black	8
13	26977	Head Cap	2
14	27022	3/8"-16, 3/4" Hex Head Bolt	1
15	20350	#10 PHP-A, 1", SS, Clear	10
16	26930	Archetype Blade Case	1
17	See Table A	A4-E Roller	Varies
18	See Table B	A1-E Roller	Varies
19	27023	Roller Spacer	1
20	19118	Small Fin Seal	8
21	26976	Sill Cap	2
22	-	Arche-Duct (1" or 1/2" NPT)	1

TABLE A: A4-E ROLLER OPTIONS

COLOR	WHEEL COLOR	ID #
Black	Black	27168
Custom color		27169
Stainless Steel	Stainless Steel	27044
Custom color		27175

TABLE B: A1-E ROLLER OPTIONS

COLOR	WHEEL COLOR	ID #
Black	Black	27171
Custom color		27170
Stainless Steel	Stainless Steel	27045
Custom color		27172

Description
Frame Assembly BOM

File Name
EDGE _s_OX Assembly

REV
B

PROPRIETARY AND CONFIDENTIAL

THE INFORMATION CONTAINED IN THIS DRAWING IS THE SOLE PROPERTY OF FLEETWOOD WINDOWS & DOORS.
ANY REPRODUCTION IN PART OR AS A WHOLE WITHOUT THE WRITTEN PERMISSION OF FLEETWOOD WINDOWS & DOORS IS PROHIBITED.

Released 3/30/2026

SHEET 3 OF 6

ASSEMBLY / PARTS LIST (B.O.M.)

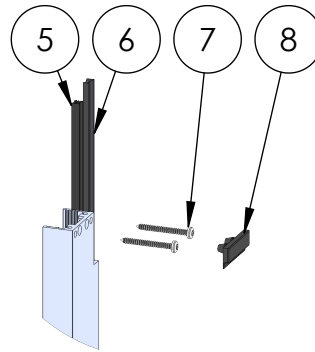
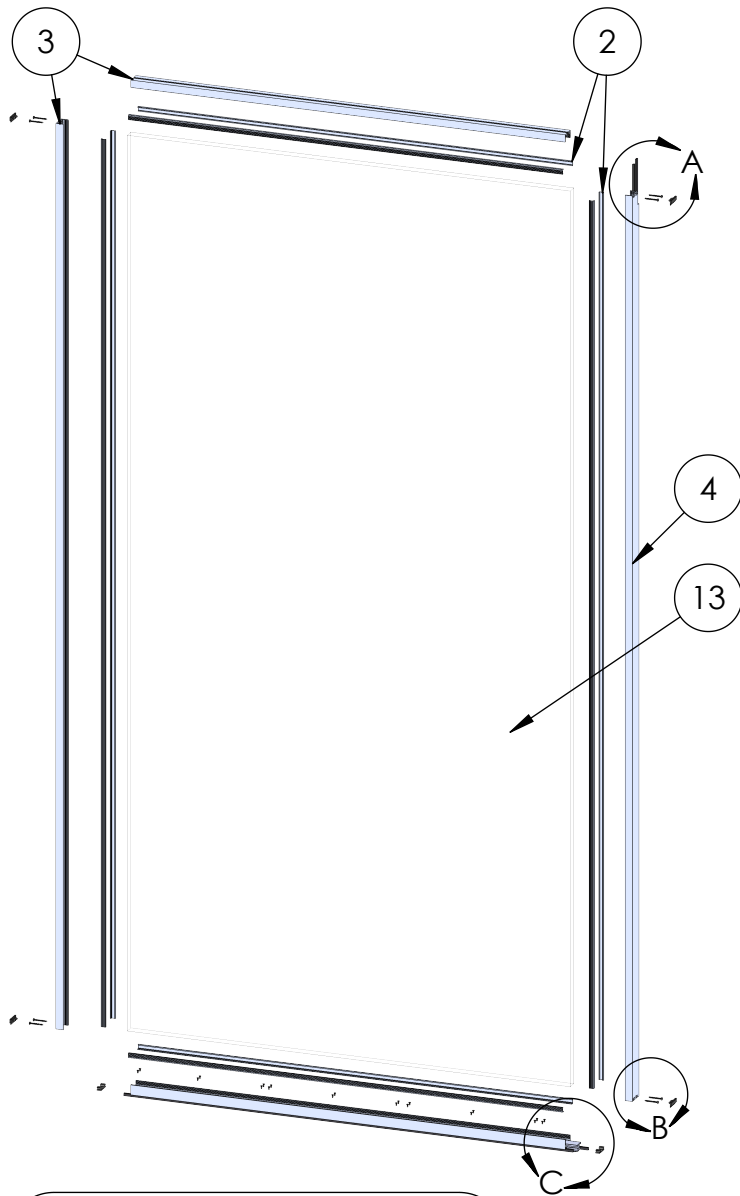

DETAIL A

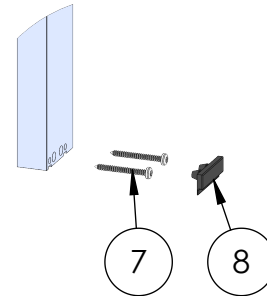

DETAIL B

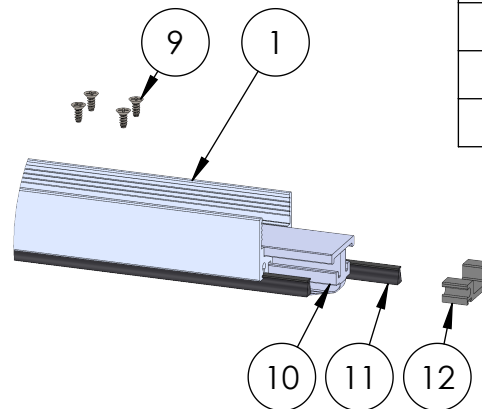

DETAIL C

Glass Keys Secured to Glass by Fleetwood, using 27091 Silkasil Sealant

EXTRUSIONS			
ITEM NO.	PART NUMBER	DESCRIPTION	QTY.
1	Es0001	Bottom Rail	2
2	Es0002	Glass Key (1 1/4" Exact)	8
3	Es0007	Top Rail and Lead Stile	2
4	Es0009	Interlocker	1
HARDWARE			
5	19117	Large Fin Seal Mohair (29027045BKGB)	1
6	27031	Large Fin Seal Mohair (50018745BKGB)	1
7	27021	#10 Torx Head, 1-3/4", SS, Clear	8
8	27017	Panel Bumper	4
9	25783	#8 FHP-B-UC, 3/8", SS, Clear	Varies
10	26467	Archetype Keel (72" Max)	1
11	27314	Fin Seal Mohair	2
12	27016	Bottom Wipe Holder	2
13	-	1-1/4" Glass	1

Description
O - Panel Assembly

File Name
EDGE_s_OX Assembly

REV
B

Released 3/30/2026

SHEET 4 OF 6

ASSEMBLY / PARTS LIST (B.O.M.)

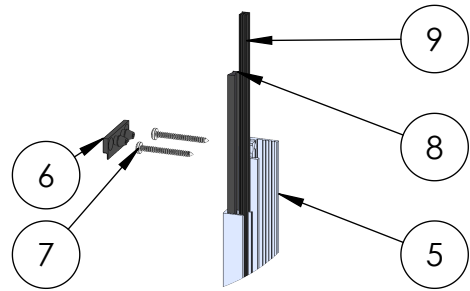
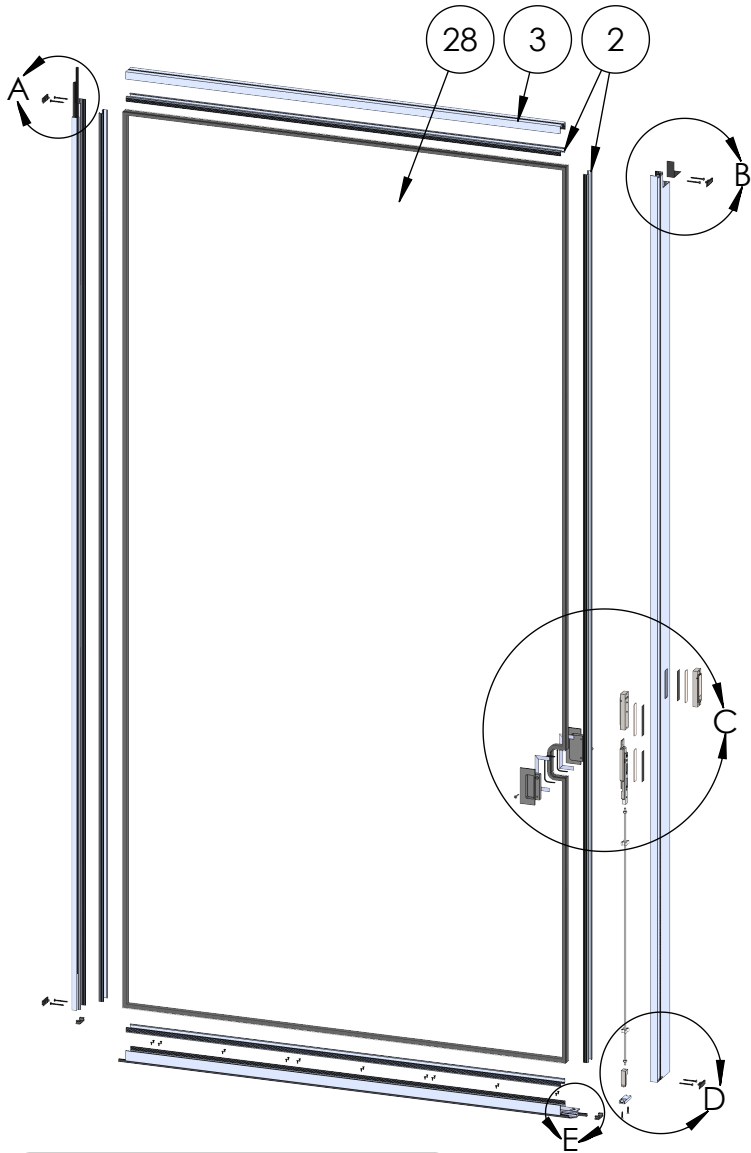

DETAIL A

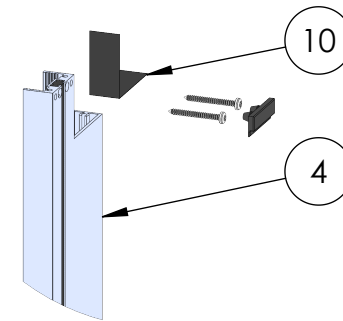

DETAIL B

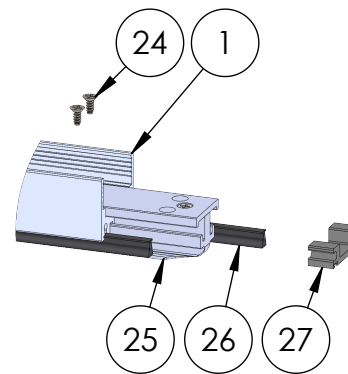

DETAIL E

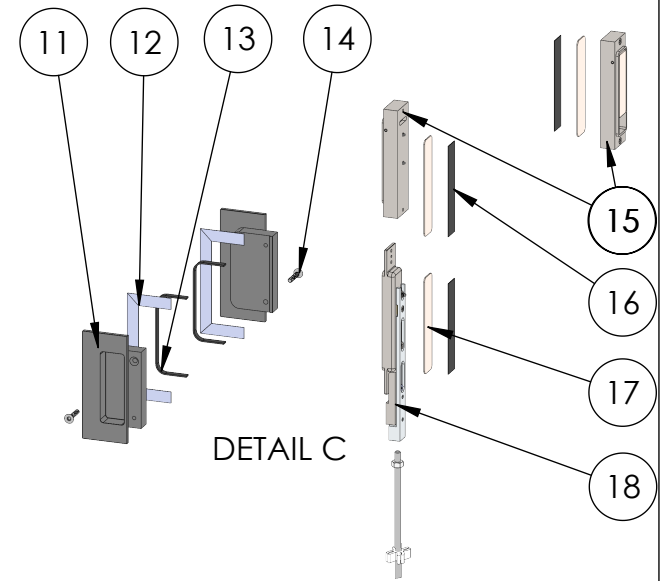

DETAIL C

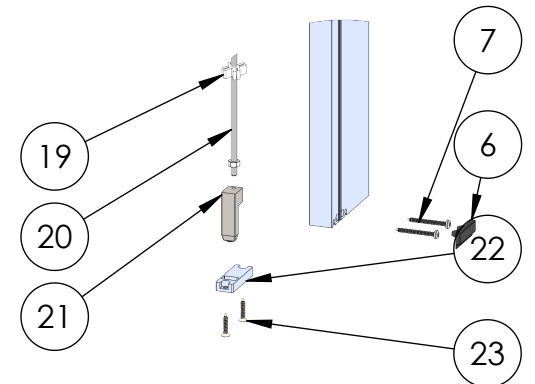

DETAIL D

Glass Keys Secured to Glass by Fleetwood, using 27091 Silkasil Sealant

PROPRIETARY AND CONFIDENTIAL
THE INFORMATION CONTAINED IN THIS DRAWING IS THE SOLE PROPERTY OF FLEETWOOD WINDOWS & DOORS.
ANY REPRODUCTION IN PART OR AS A WHOLE WITHOUT THE WRITTEN PERMISSION OF FLEETWOOD WINDOWS & DOORS IS PROHIBITED.

Description X - Panel Assembly	
File Name EDGE_s_OX Assembly	REV B
Released	3/30/2026
SHEET 5 OF 6	

ASSEMBLY / PARTS LIST (B.O.M.)

EXTRUSIONS			
ITEM NO.	PART NUMBER	DESCRIPTION	QTY.
1	Es0001	Bottom Rail	2
2	Es0002	Glass Key (1-1/4" Exact)	8
3	Es0007	Top Rail	1
4	Es0008	Fin Lead Stile	1
5	Es0009	Interlocker	1
HARDWARE			
ITEM NO.	PART NUMBER	DESCRIPTION	QTY.
6	27017	Panel Bumper	4
7	27021	#10 Torx Head, 1-3/4", SS, Clear	8
8	27031	Large Fin Seal Mohair (50018745BKGB)	1
9	19117	Large Fin Seal Mohair (29027045BKGB)	1
10	27020	Top Rail Sticker - Fin	1
11	27693	Edge-s Flush Pull - 1.25" Glass Ext-Int. Black	2
12	27752	3M VHB 4949 Tape, 0.025", 1/2" Wide, 15 Feet Long, Black	2
13	26271	1/16" x 1/4" Double Sided Foam Glazing Tape (Black) x 200ft Roll	2
14	25488	#10-32 Torx Flat Head Screw, 1", (SS, Black)	2

HARDWARE			
ITEM NO.	PART NUMBER	DESCRIPTION	QTY.
15	26925, 26926	Fin Pull (Clear, Black)	2
16	25637	3M Double-Sided Foam tape	3
17	27095	Archetype Blade Backup Plate	3
18	26919, 26920	Archetype Blade Assembly (Clear, Black)	1
19	25566	Shoot Bolt Rod Guide (Spider)	2
20	26923	Archetype Blade Shoot Bolt Rod Assembly	1
21	26921	Archetype Blade Shoot Bolt Cap Assembly	1
22	26922	Archetype Blade Shoot Bolt Guide	1
23	20293	#10 FHP-A, 1", SS, Clear	2
24	25783	#8 FHP-B-UC, 3/8", SS, Clear	Varies
25	26467	Archetype Keel (72" Max)	1
26	27314	Fin Seal Mohair	2
27	27016	Bottom Wipe Holder	2
28	-	1-1/4" Glass	1

Description X-Panel Assembly BOM	
File Name EDGE_s_OX Assembly	REV B
Released 3/30/2026	SHEET 6 OF 6