

Fenestration Testing Laboratory, Inc.

10235 8th Street, Rancho Cucamonga, CA 91730

Report T23-069

REPORT SUMMARY

REPORT

T23-069

TESTED FOR

Fleetwood Windows & Doors

1 Fleetwood Way

Corona, CA 92879

SERIES & PRODUCT TYPE

Edge | P | - Thermally Broken Aluminum Pivot Door

CONFIGURATION

X

FRAME SIZE

1936.75 mm x 3581.40 mm (76.25" x 141.00")

SPECIFICATION

NAFS - North American Fenestration Standard/specification for windows, doors, and skylights

AAMA/WDMA/CSA 101/I.S.2/A440-17

PRIMARY DESIGNATOR

With weep configuration #1 and #2

SP - PG30 1936.75 x 3581.40 mm (76.25 x 141.00 in) - Pivot Door

With weep configuration #2 - Passed water penetration at 6.06 psf

TEST COMPLETION DATE

June 26, 2023

REPORT DATE

October 11, 2023

Fenestration Testing Laboratory, Inc.

10235 8th Street, Rancho Cucamonga, CA 91730

Report T23-069

1.0 Tested For: Fleetwood Windows & Doors
1 Fleetwood Way
Corona, CA 92879

2.0 Purpose:
The purpose of this report is to present the testing methods employed and the test results obtained during the performance testing of one (1) Thermally Broken Aluminum Pivot Door described in paragraph 5.0 of this report.

3.0 Test References:

3.1 NAFS - North American Fenestration Standard/specification for windows, doors, and skylights
AAMA/WDMA/CSA 101/I.S.2/A440-17

4.0 Compliance Statement: The test results in paragraph 6.0 indicate that the test sample described in paragraph 5.0 of this report met the performance requirements of the above specifications for the performance grade shown in 4.1 below.

4.1 SP - PG30 1936.75 x 3581.40 mm (76.25 x 141.00 in) - Pivot Door

5.0 Sample Submitted:

5.1 Product Type: THERMALLY BROKEN ALUMINUM PIVOT DOOR

5.2 Series: Edge | P |

5.3 Configuration: X

5.4 Product Dimensions:	Millimeters	Inches
Total Frame:	1936.75 x 3581.40	76.25 x 141.00
Active Panel:	1901.95 x 3505.20	74.88 x 138.00

5.5 Glass and Glazing:

<i>IGU Thickness</i>	<i>Spacer Size</i>	<i>Interior Lite</i>	<i>Exterior Lite</i>	<i>Glazing method</i>
1.25" overall wide	0.75"	6mm Tempered	6mm Tempered	The glass was channel glazed as follows: Aluminum glass key extrusion is bonded to the edge of the glass full perimeter on both sides of the glass. The rails and stiles slide over the glass keys and are retained by interlocking teeth on the keys and rails and stiles. On the interior only, the key was sealed to the glass with Sikasil as indicated on page 2 "Glazing Detail".

5.6 Weepage:

The door weep system consisted of an aluminum pan or tank with a vertical leg on all sides. This pan was embedded in the floor substrate. The sill sat in the pan with a vertical leg that ran parallel and at the same height as the pan inside leg. This left a continuous 1/8" gap for water to drain into the pan. The two sill vertical legs were notched 1.06" x 0.88" at each end (see attached picture).

The pan contained threaded pipe connectors in two configurations.

Configuration #1 - three (3) 1/2" pipe coming out the front face of the pan. The spacing is shown on page 2 of 3 on the attached drawings.

Configuration #2 - three (3) 1" pipe weeping vertically through the bottom of the pan at the same spacing as configuration #2 with the same spacing as configuration #1. For both configurations, the pipes connected to a 2" PVC pipe.

The door passed air infiltration and exfiltration and water penetration at 4.59 psf with each configuration.

The door passed water penetration at 6.06 psf only with configuration #2.

Fenestration Testing Laboratory, Inc.

10235 8th Street, Rancho Cucamonga, CA 91730

Report T23-069

5.7 Pressure balancing: None

5.8 Weather-stripping:

<i>Type</i>	<i>Quantity</i>	<i>Location</i>
Hollow bulb vinyl 0.275" overall high	Four (4) strips	Each jamb contained two strips - facing out on the left side and facing in on the right (lock) side.
0.500" overall high polypile with no fin	Two (2) strips	Bottom rail facing down.
0.290" overall high polypile with center fin	Six (6) strips	Head - two strips facing down. Left jamb - two strips facing the door stile. Right (lock) jamb - two strips facing the door lock stile.

5.9 Sealants:

<ul style="list-style-type: none"> - Head to jamb frame corners were sealed full profile. - Panel corners were sealed. - Bottom of each jamb to finished floor was sealed. - The jambs and head were sealed to the rough opening on the interior and exterior perimeters.

5.10 Hardware:

<i>Type</i>	<i>Quantity</i>	<i>Location</i>
Rixon Closer and pivot at bottom and head pivot set	One (1) each	The Rixon closer and pivot were set into the pan and bottom rail respectively and the head pivot into the top rail and head respectively. The pivot point was 7" from the left jamb.
V-lock (electric lock), strike and panel backup plate	Two (2)	Lock jamb - one 24" from each end. When locks are activated, the lock bolt engages the lock strike and panel backup plate in the lock stile
Blade lock (shoot bolt)	One (1)	Bottom of lock stile. When locked, the shoot bolt engaged a strike in the floor assembly.

5.11 Construction:

<i>Location</i>	<i>Joinery Type</i>	<i>Number of Fasteners</i>	<i>Fastener Size</i>
Frame head to jambs	Mechanically joined with screws	Four (4) per corner	#10 x 1.5" PPH screws
The sill is placed inside the panning system and simulated flooring was placed on top as shown on drawings page 2 of 3, details 5 and 6.			
Stiles to rails	Mechanically joined with screws	Two (2) per corner	#10 x 2" PFH screws

5.12 Reinforcement: None

5.13 Installation:

<i>Location on frame</i>	<i>Anchor type</i>	<i>Spacing</i>
Head to rough opening	#8 x 4" PFH	A pair of screws was applied 8" from each end and 20" on center.
Jambs to rough opening	#8 x 2" PFH	A pair of screws was applied 8" from each end and 24" on center.
The pan and sill were embedded in the substrate and the sill supported by the substrate.		

Fenestration Testing Laboratory, Inc.

10235 8th Street, Rancho Cucamonga, CA 91730

Report T23-069

6.0 - Test procedures and results: All testing procedures were performed in accordance with the performance requirements of the test specifications referenced in paragraph 3.0 of this report. The number preceding each test listed below refers to the corresponding sections in the NAFS.

9.3.1 - Operation Force

Test Description	Results	Allowed	Comments
Maximum force to initiate and maintain motion	26.7 N (6.0 lbf)	Report only	1

9.3.2 - Air Infiltration (ASTM E283-04(2012)) (With both weep configurations)

Test Description	Results	Allowed	Comments
75 Pa differential pressure	1.50 L/s*m ²	1.5 L/s*m ²	
1.57 psf differential pressure	0.30 cfm/ft ²	0.30 cfm/ft ²	
The tested specimen meets the performance levels specified in AAMA/WDMA/CSA 101/1.S.2/A440 for air leakage resistance.			

9.3.2 - Air Exfiltration (ASTM E283-04(2012)) (With both weep configurations)

Test Description	Results	Allowed	Comments
75 Pa differential pressure	1.50 L/s*m ²	1.5 L/s*m ²	
1.57 psf differential pressure	0.30 cfm/ft ²	0.30 cfm/ft ²	
The tested specimen meets the performance levels specified in AAMA/WDMA/CSA 101/1.S.2/A440 for air leakage resistance.			

9.3.3 - Water Penetration (ASTM E547-00(2016)) (With both weep configurations)

Test Description	Results	Allowed	Comments
DP30 - 220 Pa (4.59 psf)	No water penetration	No water penetration	2

9.3.3 - Water Penetration (ASTM E547-00(2016)) (With weep configurations #2)

Test Description	Results	Allowed	Comments
DP40 - 290 Pa (6.06 psf)	No water penetration	No water penetration	2

9.3.4.2 - Uniform Load Deflection at Design Pressure (ASTM E330-14)

With the two V-locks engaged and the Blade lock (bottom shoot bolt) disengaged.

Test Description	Results	Allowed	Comments
DP30 - 1440 Pa (30.08 psf)Pos	1.78 mm (0.07")	Report only	3
DP30 - 1440 Pa (30.08 psf)Neg	27.94 mm (1.10")	Report only	3

9.3.4.3 - Uniform Load Structural at 1.5 x Design Pressure (ASTM E330-14)

With the two V-locks engaged and the Blade lock (bottom shoot bolt) disengaged.

Test Description	Results	Allowed	Comments
OL for DP30 - 2160 Pa (45.11 psf)Pos	1.02 mm (0.04")	13.97 mm (0.55")	3
OL for DP30 - 2160 Pa (45.11 psf)Neg	2.03 mm (0.08")	13.97 mm (0.55")	3

Comment #1 - The force was applied to the lock stile by pushing inward with the force gauge at a point approximately 40" up from the bottom of the panel on the lock stile. No closing force since the door had a closer. There is not operation force maximum allowable stated in A440-17 for Pivot Doors.

Comment #2 - No insect screen provided for pivot door.

Comment #3 - Deflection measurement taken from stile on the pivot side 137" in length between top and bottom measurement points.

Testing was witnessed by: Jim Cruz with FTL and Corey Jones with Fleetwood Windows & Doors.

Fenestration Testing Laboratory, Inc.

10235 8th Street, Rancho Cucamonga, CA 91730

Report T23-069

Additional Structural Deflection Testing in positive direction only:

With the top V-lock engaged bottom V-lock disengaged and the Blade lock engaged.

9.3.4.2 - Uniform Load Deflection at Design Pressure (ASTM E330-14)

Test Description	Results	Allowed	Comments
DP20 - 960 Pa (20.05 psf)Pos	1.78 mm (0.22")	Report only	Set was 0.04"
DP30 - 1440 Pa (30.08 psf)Pos	27.94 mm (0.27")	Report only	Set was 0.05"

Comment #3 - Deflection measurement taken from the lock stile between the top V-Lock and the bottom of the stile 117" in length between measurement points.

For a complete description of the tested sample, refer to the attached three (3) pages consisting of a bill of materials, cross section drawings, and individual part drawings. This report is complete only when all the above referenced bill of materials and drawings are attached.

The bill of materials, cross section drawings, and individual part drawings of frame and sash members are on file and have been compared to the sample submitted. Test sample sections, bill of materials, drawings and a copy of this report will be retained at the test laboratory for four years.

This test report may not be modified in any way without the written consent of Fenestration Testing Laboratory, Inc. (FTL).

The preceding test results relate only to the tested specimen and were obtained by using the applicable test methods listed in section 3.0 and 6.0 above. This report does not constitute certification of this product or an endorsement by this laboratory. It is the property of the client named in section 1.0 above. Certification can only be granted by an approved administrator and/or validator.

TEST COMPLETION DATE: June 26, 2023

REPORT DATE: October 11, 2023

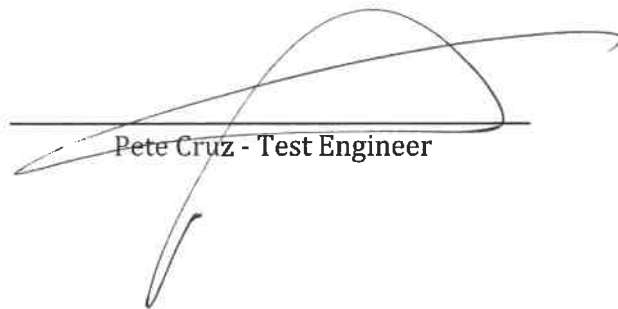

Pete Cruz - Test Engineer

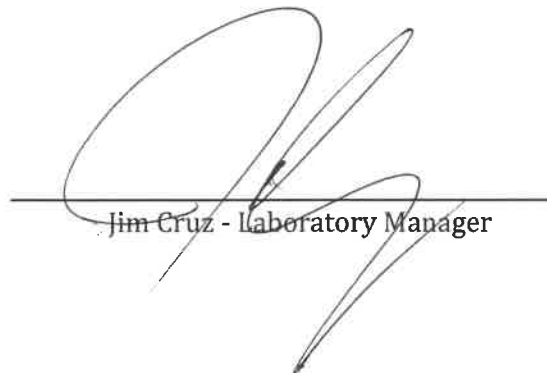

Jim Cruz - Laboratory Manager

TABLE OF CONTENTS

- SHEET NO.
 1. GENERAL NOTES, DESIGN LOADS, FRAME ANCHOR TABLE AND SPECIMEN D1 ELEVATION
 2. DETAILS
 3. BILL OF MATERIALS

TEST SPECIMEN

1. SERIES / MODEL: EDGE | p |
 2. PRODUCT TYPE: PIVOT DOOR WITH SUB DRAINAGE SYSTEM

GENERAL NOTES

1. BUCKING OPENINGS & BUCKING FASTENERS MUST BE PROPERLY DESIGNED & INSTALLED TO TRANSFER LOADS TO THE STRUCTURE AND TO BE REVIEWED BY BUILDING OFFICIAL.
 2. ALL HARDWARE & FASTENERS SHALL BE IN ACCORDANCE WITH THESE DRAWINGS & MAY NOT VARY UNLESS SPECIFICALLY MENTIONED ON THE DRAWINGS.
 3. MATERIALS, INCLUDING BUT NOT LIMITED TO STEEL SCREWS, THAT COME INTO CONTACT WITH OTHER DISSIMILAR MATERIALS SHALL MEET THE REQUIREMENTS OF AAMA AND BUILDING CODE.

SPECIFICATIONS

1. NAFS-11

CORNERS CONSTRUCTION

1. **FRAME CORNER:** THE JAMBS ARE BUTTED TO THE HEAD ATTACHED WITH SCREWS.
SILL: THE SILL IS PLACED INSIDE THE PANNING SYSTEM AND A SIMULATED FLOORING IS PLACED ON TOP.
PANEL CORNER: THE HORIZONTAL RAILS ARE BUTTED TO THE VERTICALS AND ATTACHED WITH SCREWS.

GLAZING

1.25". CLEAR 6mm-T, AIR SPACE, CLEAR 6mm-T
 ALL GLAZING SIKASIL AS-785, INSIDE KEY ALONG LENGTH, KEYS ARE EXTERIOR AND INTERIOR

SUB-SILLPAN DRAIN CONNECTION

1/2" OR 1" PVC PIPES CONNECT TO 2" PVC PIPE.

OPENING TYPE (SUBSTRATE)	FRAME TO OPENING FASTENER TYPE	MINIMUM EMBEDMENT	MINIMUM EDGE DIST.
2X_ WOOD FRAME OR BUCK	(1) NO. 8 SMS SCREW	1 1/2"	3/4"
MIN. 18 GA. 33 KSI STEEL STUD	(1) NO. 8 SMS SCREW	FULL	3/8"
CMU/CONCRETE	(2) 3/16" CONCRETE SCREWS	1 1/4"	2 5/8"

(1) SMS SCREWS
 (2) CONCRETE SCREWS SHALL BE 3/16" ITW TAPCON

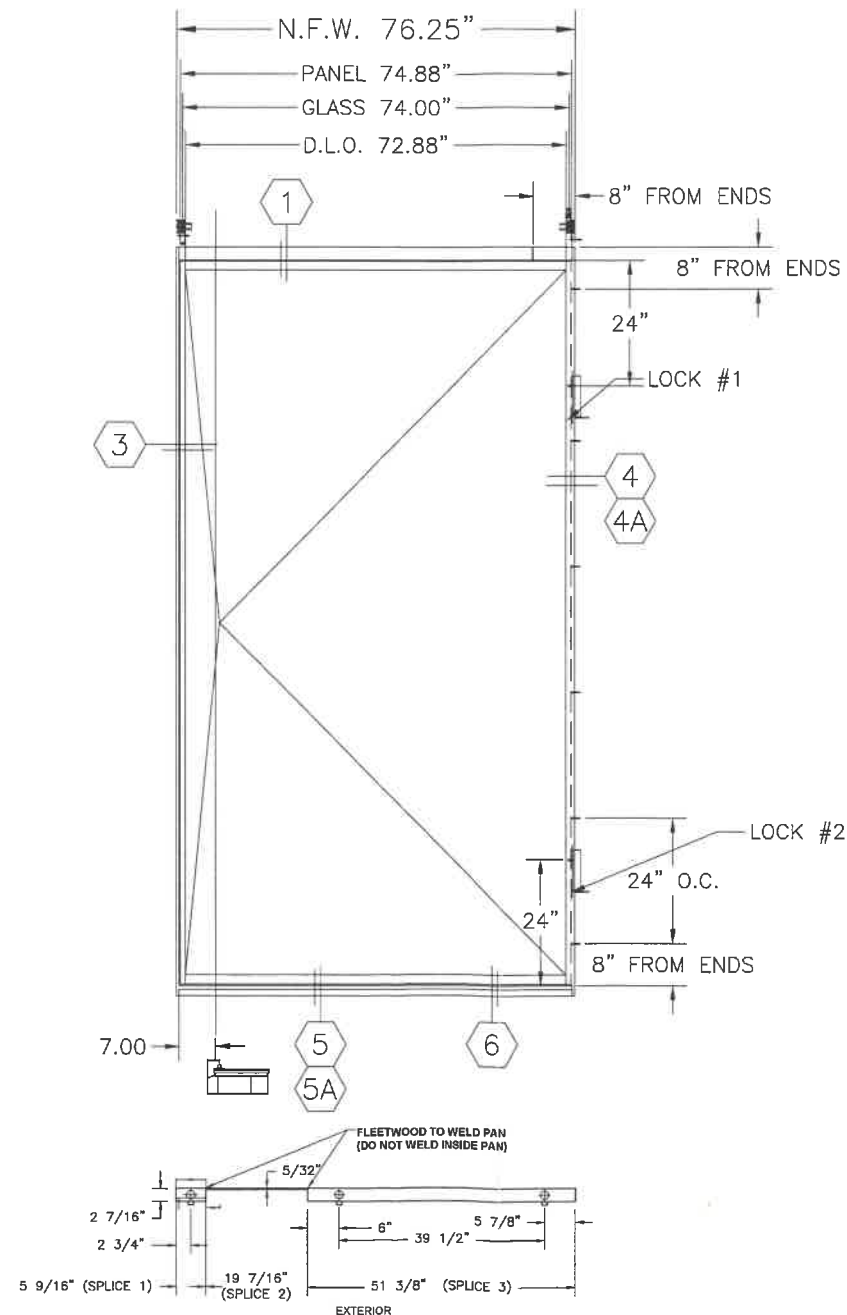
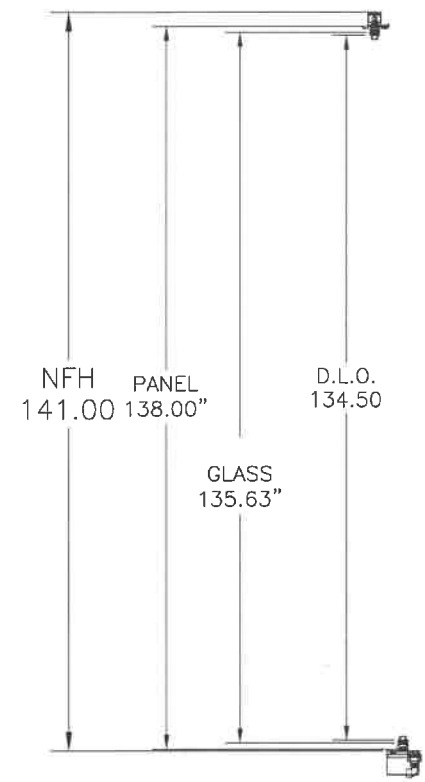

AIR		
CFM / FT ²		
INFIL.	EXFIL.	
WATER		
DP	RATING	PASS/FAIL
20	3 PSF	
30	4.5 PSF	
40	6 PSF	
50	7.5 PSF	

OPENING FORCE	
PANEL #	FORCE (LBS)
1	

LOCK OPTION	RATING	AIR INFIL.	AIR EXFIL.
1, BLADE*			
1, 2			

*=BLADE ALWAYS INCLUDED

FENESTRATION TESTING LAB
 REPORT NO: T23-069
 DATE: 10/11/23

COMMENTS					
DRAWN BY					
DATE					
REVISIONS					
DATE: 6/14/23					
DRAWN BY: CJ					
JOB NUMBER: 12382					
MATERIAL: EDGE p					
CUSTOMER: FLEETWOOD WINDOWS AND DOORS					
JOB NAME: EDGE s CERT TESTING					
1 FLEETWOOD WAY CORONA, CA 92879 www.fleetwoodusa.com					
FLEETWOOD WINDOWS & DOORS					
SCALE : 3/4" = 1'					
DRAWING NO. : (1)					
SHEET : 1 OF 3					

1 HEAD
SCALE: FULL SIZE

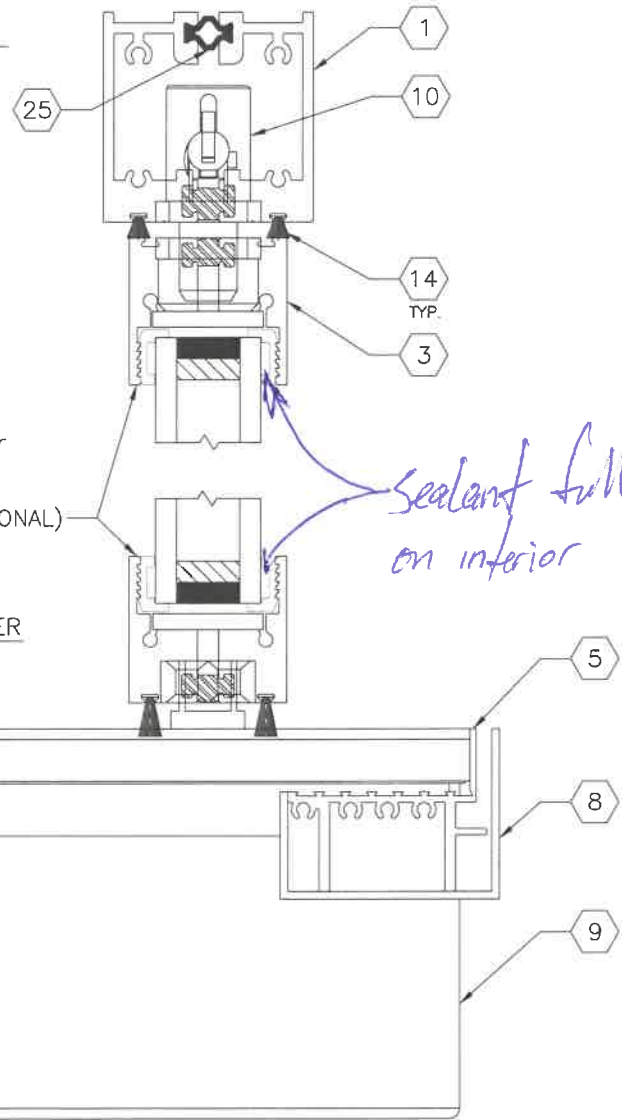

Not applied for test

Sealant full perimeter on interior

5 RIXSON CLOSER
SCALE: FULL SIZE

6 SILL
SCALE: FULL SIZE

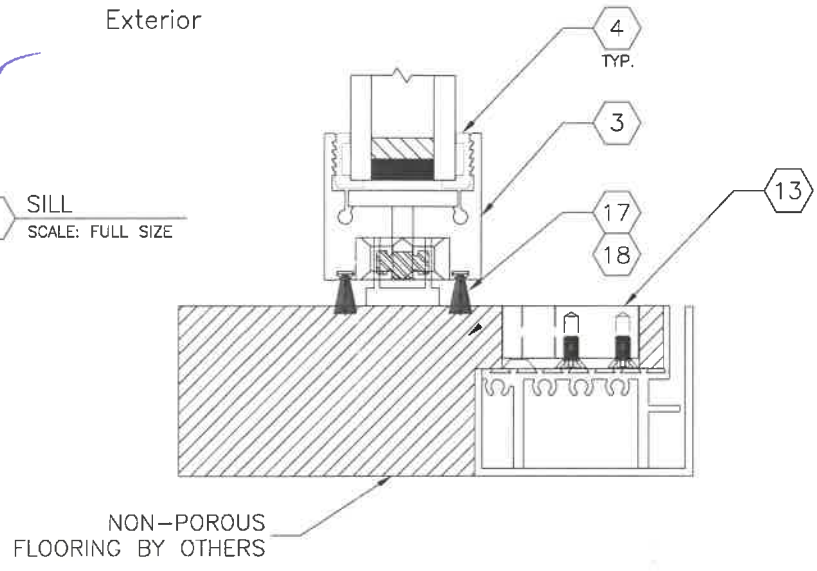

5A RIXSON PIVOT ONLY
SCALE: FULL SIZE

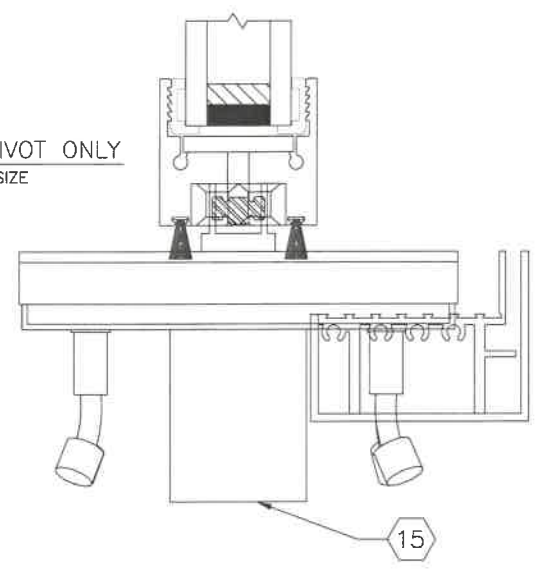

GLAZING DETAIL

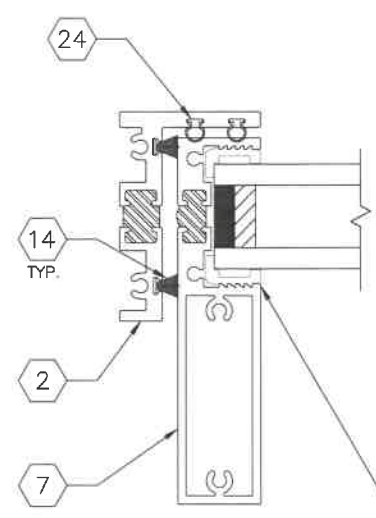
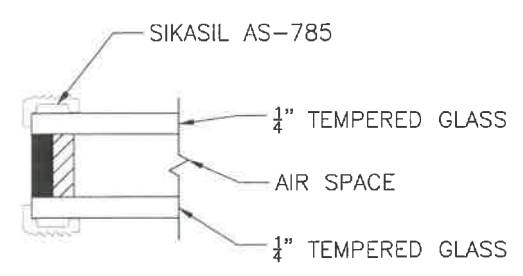

3 PIVOT JAMB
SCALE: FULL SIZE

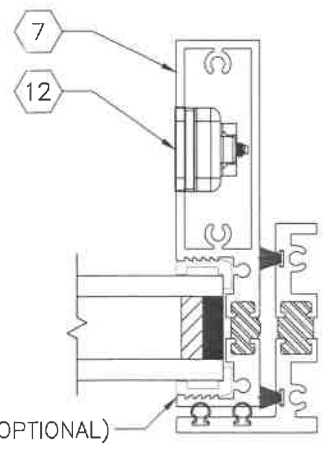

4 LOCKING JAMB
SCALE: FULL SIZE

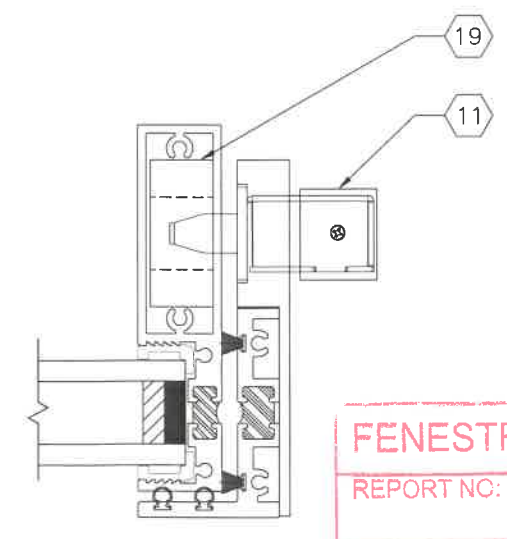

4A LOCKING JAMB
SCALE: FULL SIZE

FENESTRATION TESTING LAB
REPORT NO: 723-069
DATE: 10/11/23

REVISIONS	DATE	DRAWN BY	COMMENTS
DATE: 6/14/23	DRAWN BY: CJ	JOB NUMBER: 12382	
MATERIAL: EDGE s	CUSTOMER: FLEETWOOD WINDOWS AND DOORS	JOB NAME: EDGE s Cert Testing	
<p>1 FLEETWOOD WAY CORONA, CA 92879 www.fleetwoodusa.com</p> <p>FLEETWOOD WINDOWS & DOORS</p>			
SCALE: 1" = 1"	DRAWING NO.: (2)	SHEET: 2 OF 3	

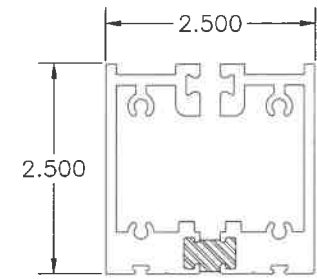

① HEAD

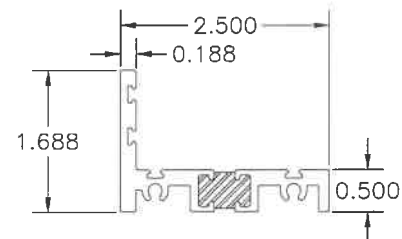

② JAMB

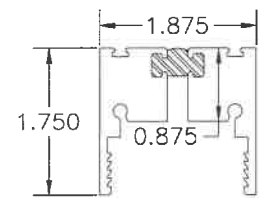

③ TOP/BOTTOM RAIL

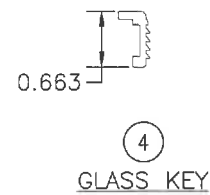

④ GLASS KEY

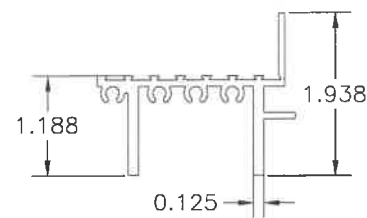

⑤ SILL

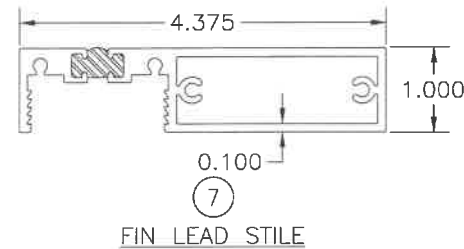

⑦ FIN LEAD STILE

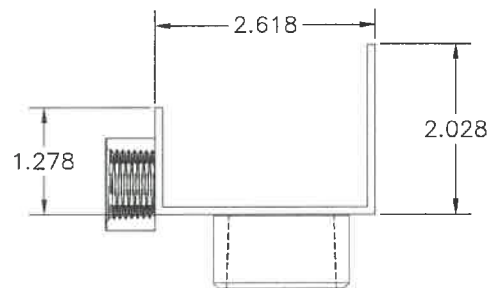

⑧ ARCHEDUCT (SIDE AND BOTTOM DRAINS)

Shown as option only

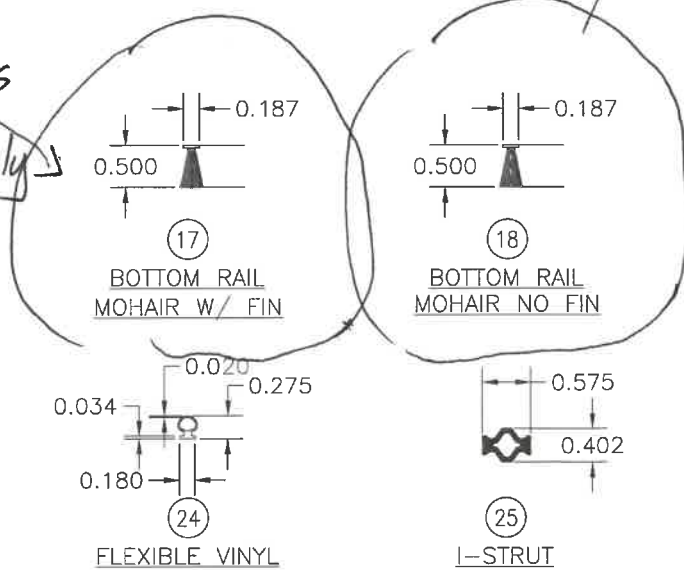

Passed reported tests with mohair or polypile with no center fin.

EXTRUSION LIST		
ITEM #	FWID	DESCRIPTION
1	Ep001	HEAD W/ STRUT (#25065)
2	Ep002	FIN-JAMB
3	Ep003	TOP/BOTTOM RAIL
4	Es0002	GLASS KEY (EXACT)
5	4411	ARCHE-DUCT SILL
7	ES0008	FIN LEAD STILE
HARDWARE LIST		
8	-	ARCHE-DUCT PAN
9	-	RIXSON CLOSER H28
10	26476	HEAD PIVOT
11	27401	V-LOCK
12	26919	BLADE (LOCKING HARDWARE)
13	26930	BLADE CASE
14	27422	MOHAIR (29018745BKGBD)
15	24987	RIXSON PIVOT ONLY
17	27031	LARGE MOHAIR (500187BKGB)
18	27421	MOHAIR (50018745BKGP-NO FIN)
19	27404	V-LOCK PANEL BACKUP PLATE
24	26233	FLEXIBLE BULB VINYL
25	25065	I-STRUT 14.6mm X 10.2mm

FENESTRATION TESTING LAB
 REPORT NO: T23-069
 DATE: 10/11/23

MATERIAL: EDGE s	DATE: 6/14/23	COMMENTS:
CUSTOMER: FLEETWOOD WINDOWS AND DOORS	DRAWN BY: CJ	REVISIONS:
JOB NAME: EDGE s Cert Testing	JOB NUMBER: 12382	DATE:
<p>FLEETWOOD WINDOWS & DOORS 1 FLEETWOOD WAY CORONA, CA 92879 www.fleetwoodusa.com</p>		
SCALE: 1" = 1"		
DRAWING NO.: (3)		
SHEET: 3 OF 3		