

TABLE OF CONTENTS

I. CARE AND MAINTENANCE..... 2

II. TOOLS / MATERIALS, SEALANT REQUIREMENTS, & LOAD / ANCHOR INSTRUCTIONS 2

III. ASSEMBLY AND INSTALLATION 2

IV. ARCHE-DUCT OPENING VERIFICATION (SKIP IF NO ARCHE-DUCT) 3

V. OPENING, FRAME AND PANEL VERIFICATION 4

 1. Opening Verification..... 4

 2. Pre-Fit and Leveling..... 4

 3. Flash the Opening..... 4

 4. Arche-Duct Water Test 5

 5. Arche-Duct Install 5

 6. Confirm Weeping Slots 5

 7. Backfill 5

VI. FRAME ASSEMBLY 5

VII. FRAME INSTALLATION 6

VIII. FLOOR CLOSER INSTALLATION..... 7

IX. GLASS KEY ASSEMBLY (FOR REPLACEMENT GLASS)..... 9

X. PANEL INSTALLATION..... 10

XI. V-LOCK TESTING..... 11

XII. BLADE CASE INSTALLATION..... 12

XIII. FINISHED FLOORING INSTALLATION..... 12

APPENDIX A: ARCHE-DUCT DIMENSIONAL REFERENCES 13

APPENDIX B: RIXSON ADDITIONAL REFERENCES 14

APPENDIX C: WIRING SCHEMATIC 15

APPENDIX D: V-LOCK LOCATIONS AND KNOCKOUTS..... 16

APPENDIX E: MULLION INSTALLATION..... 17

APPENDIX F: HANDLE PULL OPTIONS 18

I. Care and Maintenance

Operational Warning: Fleetwood products operate smoothly and special care should be taken by the owner to make sure users are not injured.

This product is factory finished. Please handle with extreme care. Protect all exposed surfaces from contact with caustics, corrosives, solvents, abrasions, impacts, wet packing material etc.

FAILURE TO DO SO WILL NULLIFY THE WARRANTY. Before **ANY CLEANING**, review the Care & Maintenance Instructions (go to www.fleetwoodusa.com for more information). **Contact the local dealer with any questions or concerns.** Fleetwood strongly recommends that all products be cleaned after installation and totally protected from construction debris and equipment.

II. Tools / Materials, Sealant Requirements, & Load / Anchor Instructions

Tools Required: Tape measure, Soft mallet, adjustable crescent wrench, Plumb bob / line, Flat head screwdriver, Laser Level or 8' level, Shims, Nails, Screws, Sealant, caulk gun, Backer Rod, Scissors or utility knife, hex keys, drill bit, drive bit and powered drill.

Sealant Requirements

- The sealant referred to within this document for seals associated with the assembly of the product should conform to **AAMA 800**. It is recommended that all other sealants conform to **AAMA 800** but may be a sealant recommended and approved by the sealant manufacturer that is compatible with the framing, finish, and surrounding materials.
- All sealant bead sizes must conform to the sealant manufacturers' size requirements.
- The Owner / General Contractor is responsible for identifying the need for any additional sealant to be applied by others. Such sealant shall be elastomeric material, with the framing, finish and surrounding materials.

Load / Anchor Instructions

- Live or Dead Loads can affect product functionality, loads shall be designed to withstand the most critical effects of load factors and load combinations as required by building code.
- Fleetwood requires maximum vertical deflection of the header not to exceed $\text{Span}/720$ or $1/8''$
- Structural engineer to determine anchor quantity and spacing for design load requirements.
- Review panel pressure loads and lateral force with flooring manufacturers specifications.
- Proper material must be used between all dissimilar materials (i.e. block/concrete & aluminum).

III. Assembly and Installation

General: The key to any window or door installation is preparation. This extends from storage of the product to the final installation and to all points in between. Careful planning and attention to detail can help ensure proper installation.

It is essential that each Fleetwood product be assembled and glazed in accordance with AAMA standards and factory instructions. It is the installer's responsibility to ensure that each Fleetwood product is assembled, glazed and installed and completely sealed to ensure that the product is leak-free and operates correctly. **Installation of Fleetwood products must be in accordance with the standards set forth in ASTM E 2112.** If there are any questions regarding the installation of a Fleetwood product contact the factory customer service department.

Fleetwood has provided this product with recommended field glazed weather-stripping. If the provided weather-stripping does not ensure an optimum fit of glass to frame the Fleetwood

Authorized Dealer should contact Customer Service for an expedited NO CHARGE shipment of replacement weather-stripping.

IV. Arche-Duct opening verification (skip if no Arche-Duct)

Table 1: Arche-Duct Framing Dimensions

Model	A	B	C	D	E	F	G
H28	N.F.W. + 1.00"	3.75" 5.25" Sillpan Tabs	4.25" 3.5" Sillpan Tabs	Pivot Distance - 2"	13.375"	A - (D+E)	8.00" 9.5" Sillpan Tabs
Pivot Set							

For additional dimensions see Appendix A.

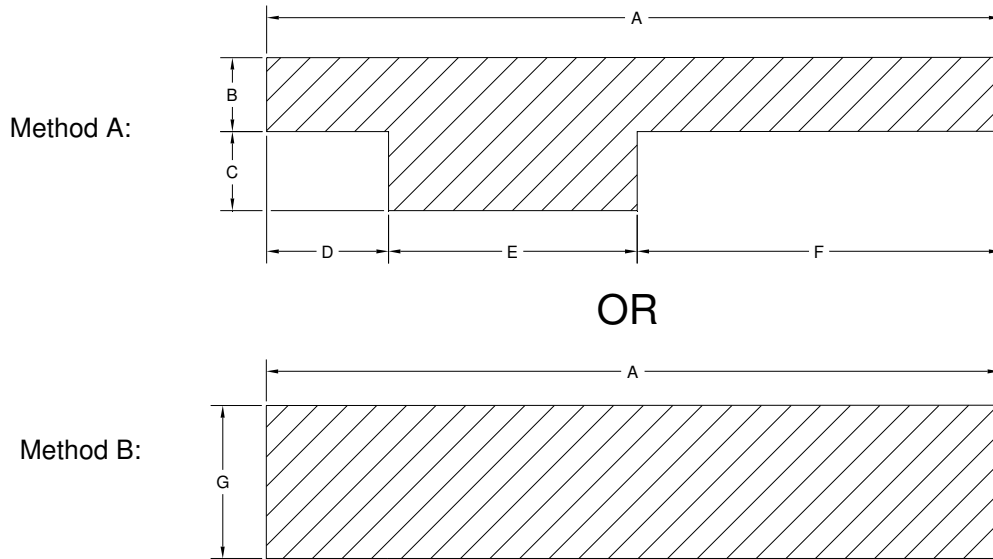
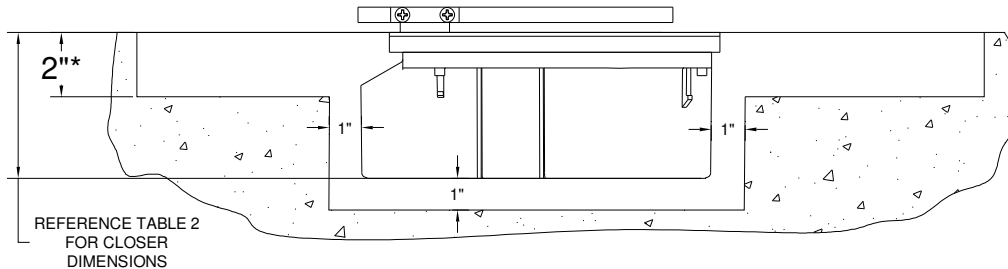

Figure 1:
Arche-Duct Framing (Top View)



* Minimum depth required for Arche-Duct and Rixson closer. Additional depth may be required for drainage. Side drains sit $\frac{3}{16}$ " below bottom of Arche-Duct

Figure 2:
Closer Arche-Duct Opening (Side View)

V. Opening, Frame and Panel Verification

1. Opening Verification

- Check the measurements of the opening and verify that the door will fit into the opening. Measure all four sides of the opening to make sure it is 1/2" larger than the doors in width and 1/4" in height.
- Verify the opening is plumb, square, and level (Figure 3).
- Verify location / dimension Arche-Duct opening (Figure 1,2).
- Remove the frame from packaging (save all red bag items for use later) and lay it in front of the opening. Check door net frame width / height dimensions and verify pivot distance (per order).

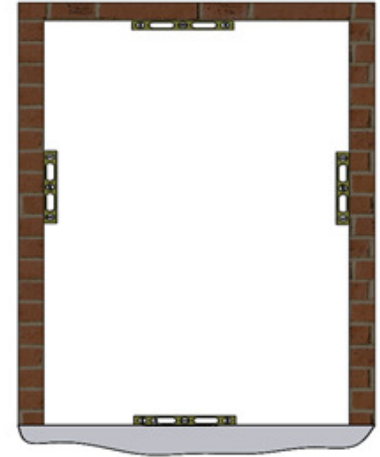

Figure 3:
Level Locations

2. Pre-Fit and Leveling

Note: Do not leave the Arche-Duct system exposed for more than 3 months. Prolonged exposure will damage the powder coated finish.

- Place the Arche-Duct drain system into the opening and determine any leveling that must be done prior to installation (Figure 3). Prepare relief areas for the PVC drain flange(s).
- Shim as necessary to stabilize the entire depth and length of the Arche-Duct. No unsupported width of more than 8" is allowed. Shim to be load bearing, non-porous, non-absorbent and inorganic.
- If more than 1/8" shim height is required, it is recommended that pouring self-leveling "Rock Hard" (or equal) to achieve level and stable surface.

3. Flash the Opening

- Once the opening has been confirmed, flashing of the opening is required prior to Frame installation. Paper and/or liquid flashing methods are acceptable (see AAMA 711/714 for material requirements).
- Check local Building codes for any additional flashing requirements.

Paper Flashing

- At each Jamb the flashing paper should be cut at least 3" past the weep-screed or diado flashing and at least 6" above the head of the door. The flashing must wrap around the jamb and at least 3" back into the opening.
- At the Head run the flashing paper long enough to extend at least 3" past the jamb flashing and wrap around the Header at least 3" into the opening.

Liquid Flashing

- Follow the liquid flashing manufacturer instructions.

4. Arche-Duct Water Test

Note: Installer responsible for verifying the integrity of the Arche-Duct for water leakage and performance.

- Block all drain outlets and fill the Arche-Duct with water to verify the integrity of all seams and drain connections. Look for leak points, the water level of the Arche-Duct should remain constant. If the Arche-Duct passes water test, drain Arche-Duct and continue with installation of frame.

5. Arche-Duct Install

Note: Do not leave the Arche-Duct system exposed for more than 3 months. Prolonged exposure will damage the powder coated finish.

- Confirm proper orientation of Arche-Duct for tracks and drain location with customer order and/or dealer drawings.
- Install Arche-Duct into already leveled opening. An insulating material should be placed between the Arche-Duct and the supporting structure (concrete, steel, etc.) to prevent corrosion of the aluminum Arche-Duct.
- Connect tubing or pipe to Arche-Duct drain connections.

6. Confirm Weeping Slots

- Typical weep slot quantity to be 3 per single panel configuration.

7. Backfill

- Do not back-fill until door operation is fully tested, including locking into jamb(s).
- Verify you have access to drainage connections and clean out as necessary.

VI. Frame Assembly

Note: Failure to assemble the frame according to the installation instructions, nullifies warranties related to this product.

- Apply a compatible sealant to the corners of the frame. Assemble the frame with screws provided (Figure 4).
- Mullion installation instructions see Appendix E.

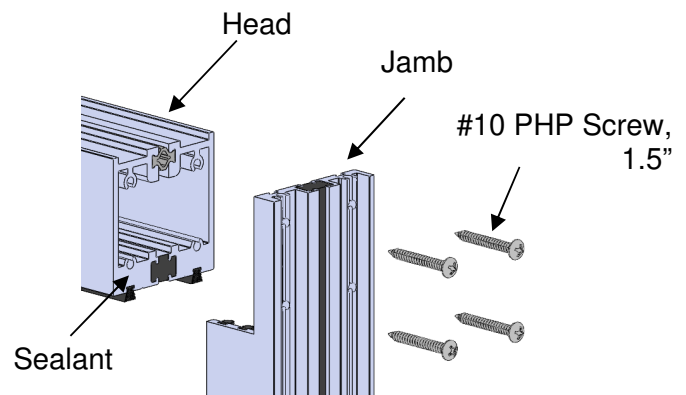

Figure 4:
Frame Assembly

VII. Frame Installation

Note: Fleetwood recommends the use of a laser level or 8' level for frame installation. Cross-measure within $\pm 1/32"$ for interior and exterior.

1. If the product has V-Locks attach the wiring harness to the V-Lock now. After frame and panel installation is completed it is recommended that operation of the V-Lock is tested. See Section XI for instructions on how to test the operation of the V-Lock.
2. Seal frame and vent joints completely with compatible sealant.
3. Insert the frame into the Arche-Duct. Cross-measure and adjust to achieve a plumb square and level condition. Shim where needed. Seal all fastener heads with compatible sealant.
4. Insert sill extrusions into Arche-Duct.
5. Secure top pivot to header with #10 screw min. 4" long (not by Fleetwood). See Figure 5 for illustration.

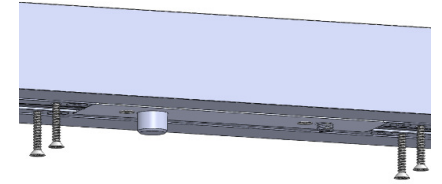

Figure 5:
Securing Top Pivot

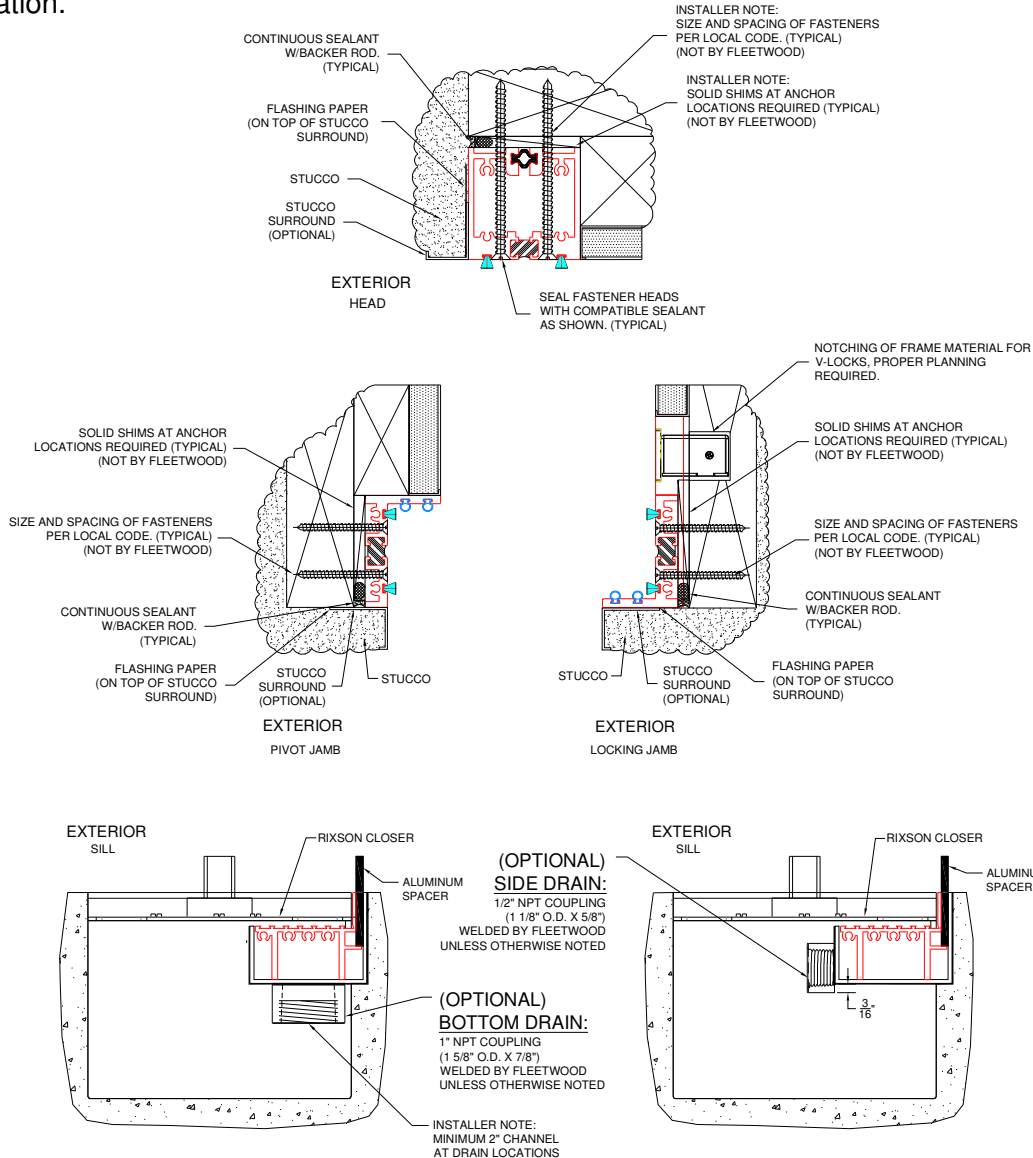

Figure 6:
Closer Block Frame Installation

VIII. Floor Closer Installation

• Do not use the Rixson provided floor plate.

1. Set the closer into the floor 1-1/4" from the back of the jamb and level (confirm with plumb line as stated in step 4). Closer is to be installed in line to the door and flush to the floor (Figure 7).
2. Measure dimension of "A" as specified from opening to the spindle center (Figure 8 & Table 2).
3. Set closer surface 5/8" below the finished floor. Cover plates will be flush to finished floor. Continue to step 4.

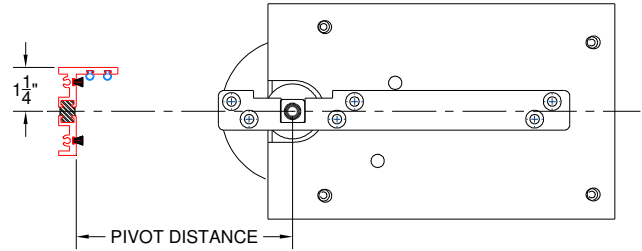
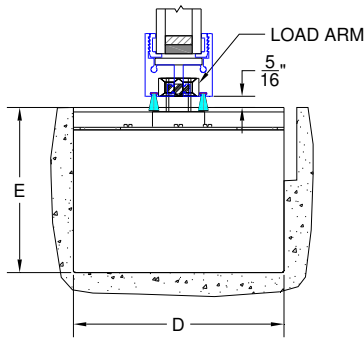
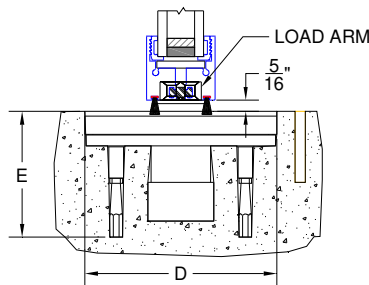

Figure 7:
Closer Positioning



Closer H28-587 Shown.



Pivot H117-587 Shown.

Rough Opening
(Assuming 1/4" shim)

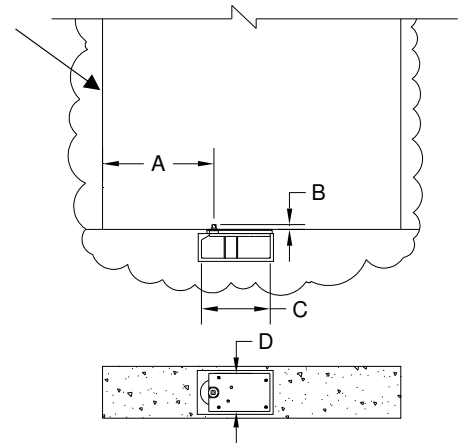

Closer H28-587 Shown.

Figure 8:
Frame, Closer, Pivot Opening

Table 2: Pivot Location, Floor Closer & Pivot Set Dimensions.

Model	A	B	C*	D*	E*	Cover Plates
Closer H28-587	Pivot Distance + 0.75"	0.75"	11.375"	6.125"	4.625"	0.625"
Pivot H117-587			6.5"	5.5"	3.5"	

* Hole rough opening: add a minimum 1.0" around the closer (& pivot set) for cement or equivalent back fill.

- Use a plumb line to center top pivot pin with center of closer spindle (Figure 9).

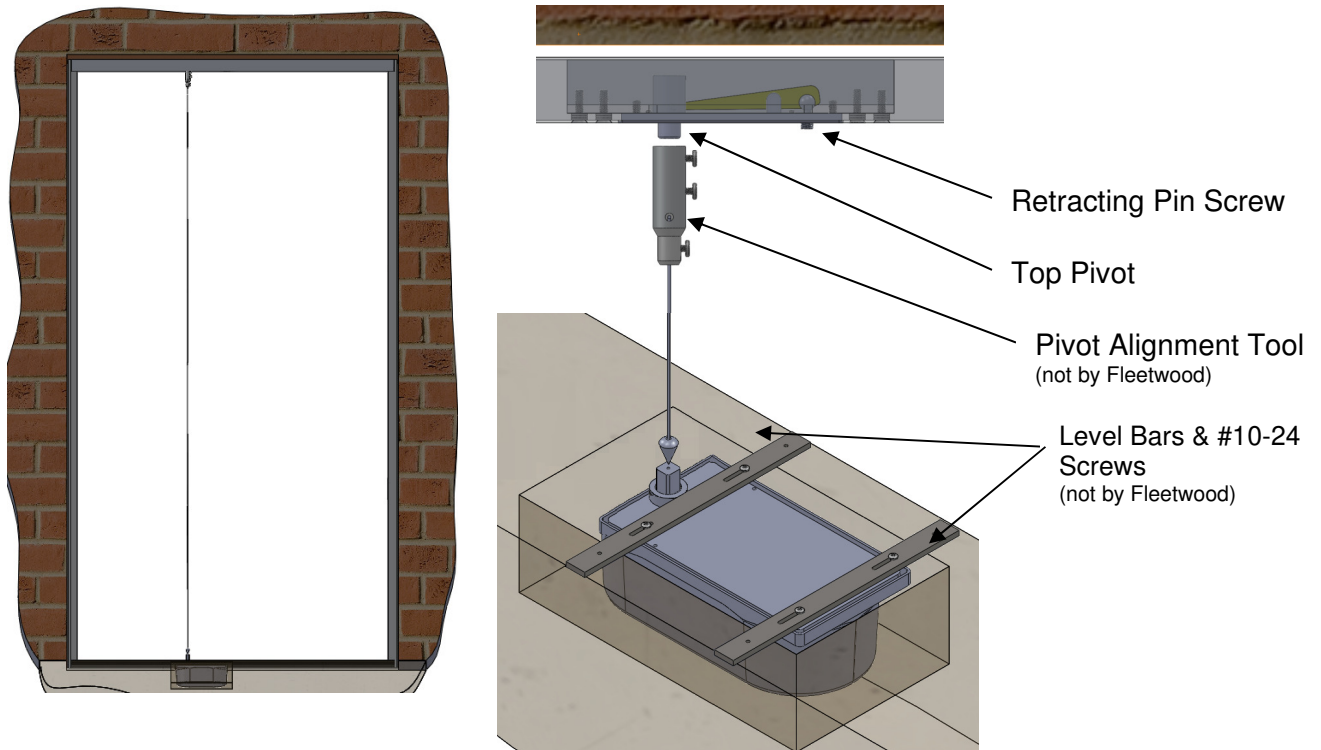

Figure 9:
In-line Verification

- Grout in closer with cement or equivalent. Continue to Section X, panel installation when cement is cured.
- Complete flooring around closer and Arche-Duct.
- Install cover plates to closer (Figure 10).

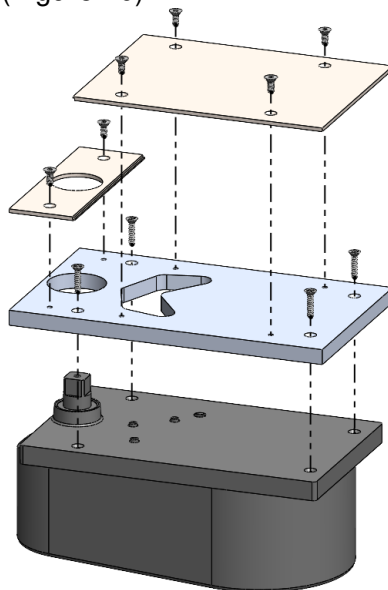

Figure 10:
Cover Plate Installation

IX. Glass Key Assembly (For Replacement Glass)

Note: Replacement glass, request glass keys from customer service, installer to size and cut.

1. Measure the glass thickness along all 4 sides of the glass.
2. Add the measurements together and divide by the number of measurements taken. This is the average glass thickness.
3. Use Table 3 to select the appropriate glass keys. Figure 11 can be used to properly identify the glass keys.

Table 3: Glass Key Selection

Average Glass Thickness	Extrusion
0.563"	Es0021
1.1875"-1.212"	Es0017
1.213"-1.237"	Es0017 & Es0002
1.238"-1.262"	Es0002
1.263"-1.313"	Es0002 & Es0018

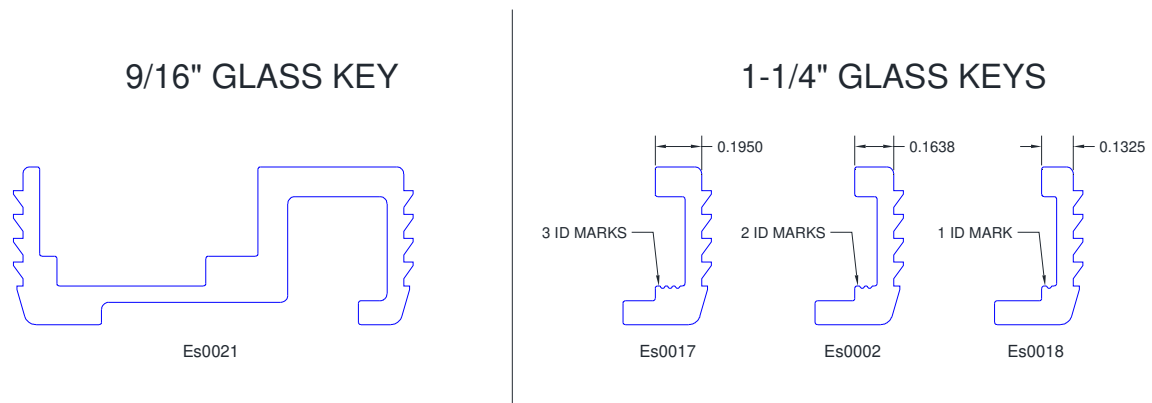

Figure 11:
Glass Key Identification

4. Measure the side of the glass where the glass key is to be placed. Subtract 1-1/8" from the measurement. This is to leave a 9/16" gap at the corners of the glass, without this gap it will not be possible to slide / remove panel components.
5. Cut the glass keys to size. Clean off any debris.
6. Place 1/4" x 1/4" bead of structural sealant along middle of glass keys.
7. Press the glass key to the face of the glass. The key needs to be placed firmly against the edge of the glass (Figure 12). This is most easily achieved by pressing at a 45° angle onto the glass.
8. Repeat the procedure for all sides top and bottom of the glass.
9. Apply a bead of sealant that is compatible with the insulated glass seal to all four **exterior** corners as shown in Detail "A".

Notes:

- a. The glass thickness, net width and height must be to size within +/- 1/32".
- b. Failure to install according to these instructions nullifies all warranties related to this product.

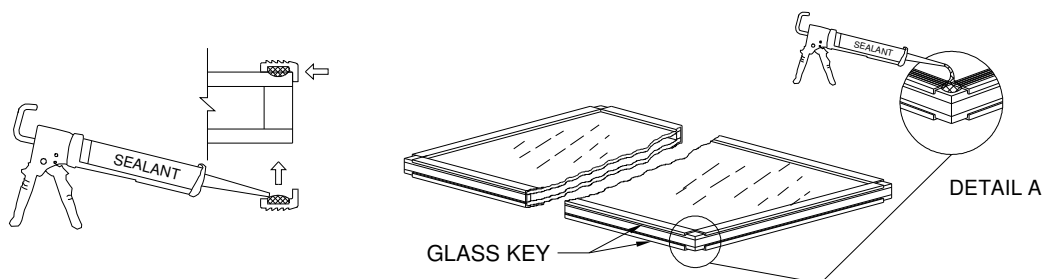

Figure 12:
Glass Key Application

X. Panel Installation

- **Closing Speed Adjustment** see Appendix B.
- **Do not include the bearing cover on closer.**

1. Retract top pivot pin by turning retracting pin screw counterclockwise (Figure 13). Install washer & thrust bearing to spindle (Figure 15).
2. On the panel, remove the Load Arm Cover Plate with a T15 torx bit. Then remove the (2) Phillips head screws holding the Load Arm Block in place (Figure 14).
3. With the floor closer in the slowest settings use a crescent wrench to turn the pivot perpendicular to the frame.
4. Tilt door to place on spindle (Figure 15) and attach Load Arm Block but do not tighten.
5. Align the two portions of top pivot and turn pin retracting screw clockwise (Figure 13).
6. Tighten Load Arm Block screws and install Load Arm Cover Plate.
7. The installer is responsible for the integrity of all framing joints after installation and must therefore water test all joints to guarantee a completely sealed product. Apply joint sealer and/or sealant necessary to ensure watertight joints. Retest as necessary.
8. To complete the panel installation, apply backer rod and a complete bed of sealant to the entire exterior and interior joint between the frame and the building structure. Tool the sealant to eliminate bubbles, voids and / or breaks and ensure a completely watertight seal (Figure 6).

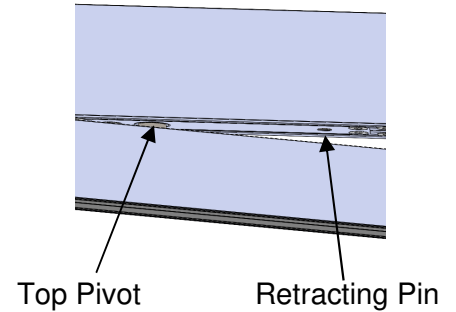

Figure 13:
Top Pivot Locking

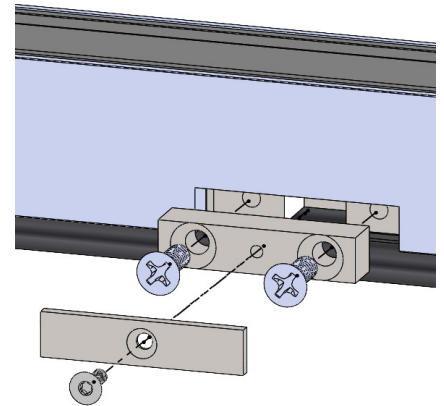
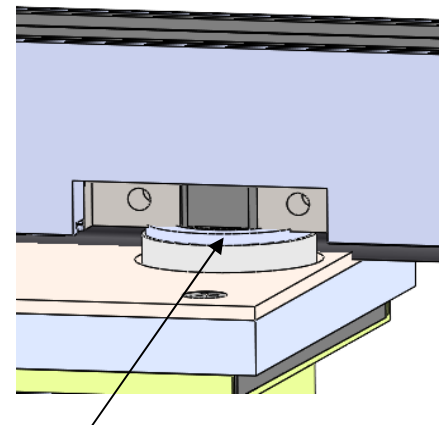

Figure 14:
Load Arm Cover Plate / Block Assembly



0.10" thick Shim is above
Thrust Bearing

Figure 15:
Shim Location, Interior
(weatherseal removed for clarity only)

XI. V-Lock Testing

- **V-Lock Wiring & Indication LED** see Appendix C or included V-Lock Instructions
- **FOR TESTING ONLY**
- **ONE test kit per door** (regardless of quantity of locks).
- **ONE Wiring Harness per V-Lock**

Note: The V-Lock Wiring Harness will need to be accessible for testing and special care should be taken to not damage the connection between the latch and the harness.



Figure 16:
V-Lock Testing Kit

1. Fleetwood has provided the following kit in order to test the operation of the V-Lock only, it is not meant for permanent use. This testing is to be done prior to adding the surround to the frame.
2. Unbox the V-Lock Test Kit. This kit includes a power adapter, toggle switch, and a quick connect as shown in Figure 16 (the wiring harness is to be installed to the V-Lock during the frame installation phase to avoid any need to remove the lock from the frame).
3. Use the wiring diagram (Figure 17) to wire the V-Lock to the Testing Kit.
4. The lock is provided in a fail-safe mode, when the toggle switch is in the I position and the panel is closed the V-Lock should move to the locked (extended) position, indication LED should display red. When power is removed, the lock should retract to the unlocked position (toggle switch, O position), indication LED should display green.
5. Once operation of the lock is observed, return the V-Lock to the unlocked position.
6. Unplug the adapter from the wall outlet / power supply and remove the connections from the wiring harness to the quick connect, special care should be taken to not damage the connection between the latch and the harness.

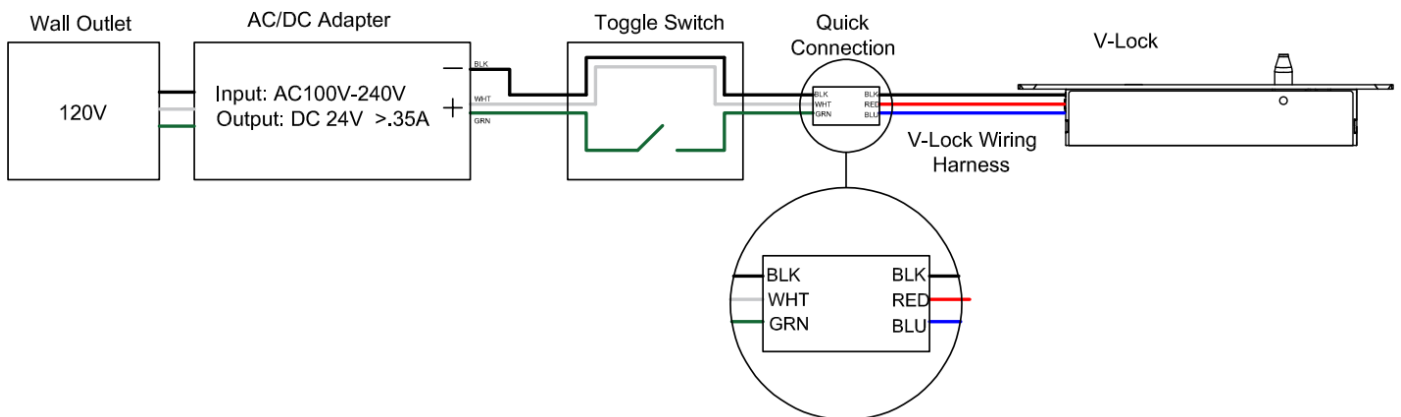

Figure 17:
Wiring Diagram
(V-Lock shown in the locked position)

XII. Blade Case Installation

Note: Any gaps between blade case and finished flooring/jambs must be sealed to prevent water infiltration.

1. Determine the location setting for the blade case (Figure 18). Remove screws (from the underside) and reassemble as necessary (Figure 19).
2. Mark the blade case locations.

Method 1:

If the panel is un-installed the case locations can be determined from dealer drawings.

Method 2:

If the panels are installed the blade can be activated and the location marked.

3. Predrill holes for a #10 screw using a #25 drill bit. Fasten blade case with #10 X 1" PHP Screw.

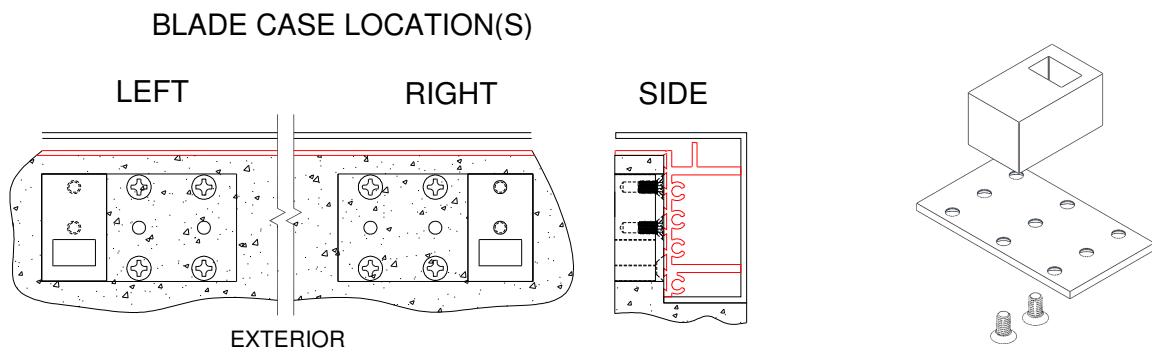

Figure 18:
Blade Case Location Options

Figure 19:
Blade Case Disassembly

XIII. Finished Flooring Installation

Flooring Material: The sill for this product was designed to incorporate the finished flooring as a key component to the bottom rail sealing and the linear slot drain. The material chosen to surround the extruded sill should be such that water will not damage it.

Linear Slot drain: The sill comes with an aluminum spacer to ensure the linear slot drain spacing is correct. This spacer is to be removed after the flooring is installed.

Appendix A: Arche-Duct Dimensional References

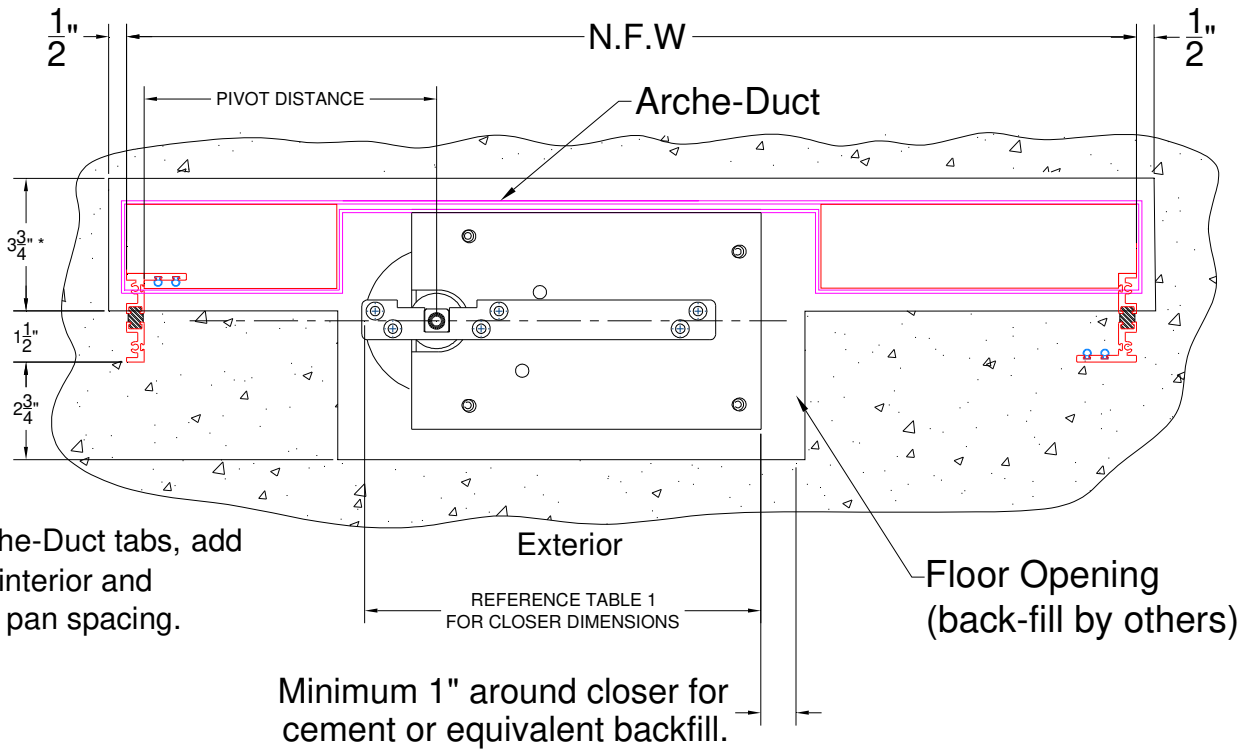

*For Arche-Duct tabs, add 1.5" on interior and exterior pan spacing.

Figure A1:
 Closer Arche-Duct Opening
 (weatherseals removed for clarity only)

Appendix B: Rixson Additional References

Closer Adjustment

PAGE 4

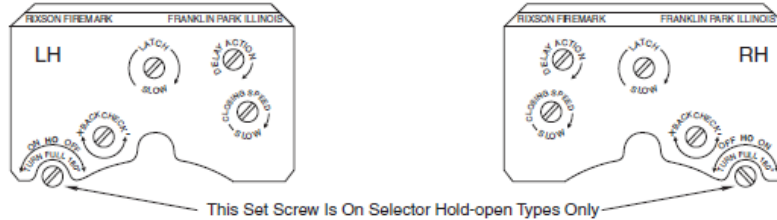

Closing speeds can be adjusted to suit local conditions and requirements. Label on closer face designates the purpose of each adjustment screw. Adjustments are for speed control.

Do not use Backcheck as deadstop. This is an intensity valve not speed control.

- A. The Delay Action valve allows adjustment from full open to 65° closed position. (Optional)
- B. The Closing Speed valve allows adjustment from full open to 15° on units without the Delay Action feature.
- C. The Closing Speed valve allows adjustment from 65° to 15° closed position on closers with Delay Action feature.
- D. Latch valve allows adjustment from 15° to closed position.
- E. Important: Backcheck adjustment must be adjusted to vary resistance from light to firm at 60° of door open.

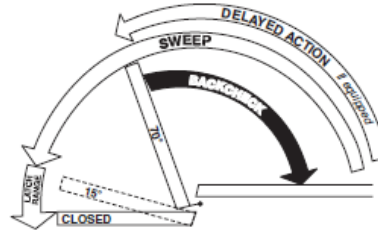

Closer Type

This closer is one of three types as follows:

- 1. Non hold-open factory set. No hold-open adjustments.
- 2. Automatic hold-open factory set. No hold-open adjustment.
- 3. Selective (on-off) hold-open label will indicate position of on-off selector screw. When turned "on", closer has automatic hold-open: turned "off", hold-open will not function. Turn full 180°.

Spring Power Adjustments

This closer can be adjusted for increased or decreased spring power.

These adjustments if required should be done by an authorized repair agency.

Repairs, parts replacement or internal adjustments must be done by a Rixson authorized repair agency. Consult www.rixson.com for an authorized repair agency in your area.

ASSA ABLLOY is the global leader in door opening solutions, dedicated to satisfying end-user needs for security, safety and convenience. Rixson® is a registered trademark of Yale Security Inc., an ASSA ABLLOY Group company. Copyright© 2006, 2009, Yale Security Inc., an ASSA ABLLOY Group company. All rights reserved. Reproduction in whole or in part without the express written permission of Yale Security Inc. is prohibited.

Rixson Specialty Door Controls

www.rixson.com

RIXSON
ASSA ABLLOY

866-474-9766 Technical Department

Figure B1:
Rixson Closer Adjustments

Appendix C: Wiring Schematic

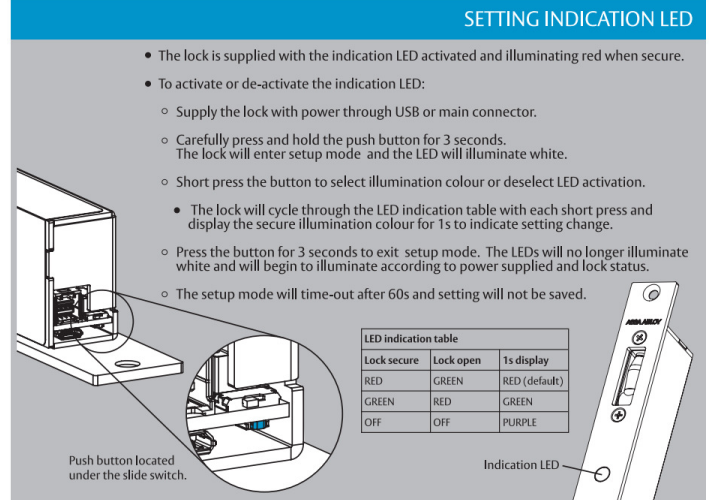
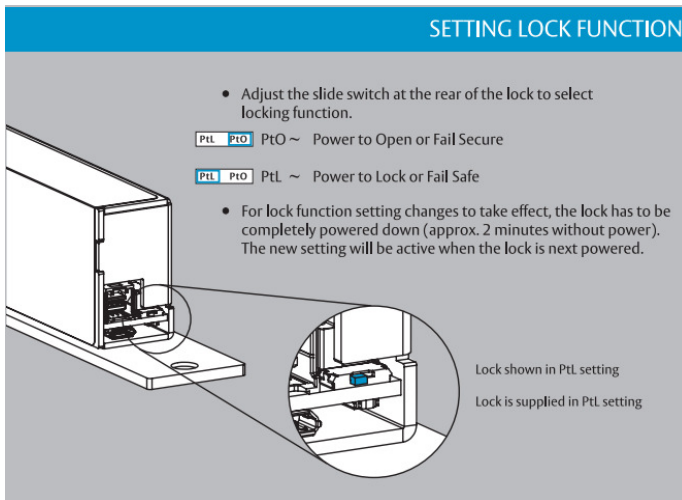
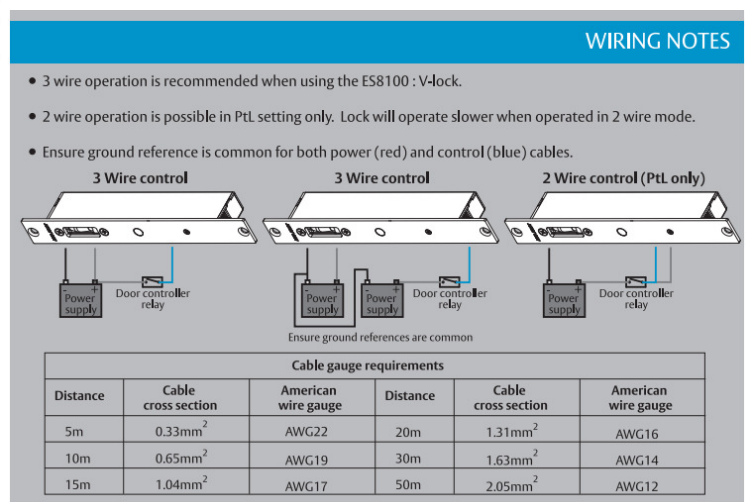
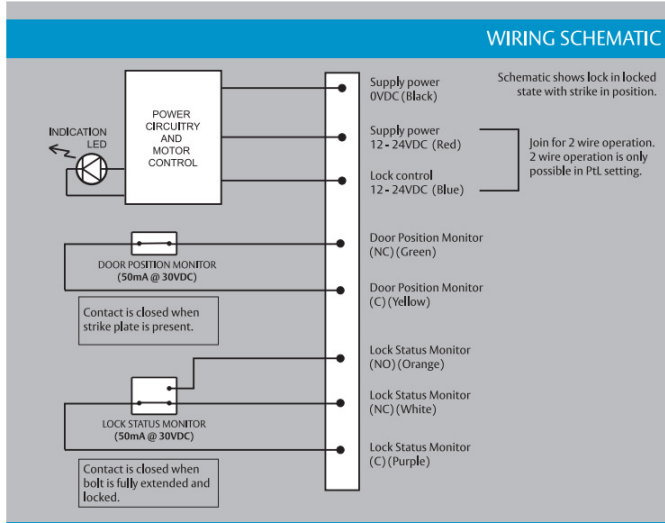

Appendix D: V-Lock Locations and knockouts

- When hardware type “V-Locks Both Jamb” is chosen, the V-lock(s) location on the pivot side will match the location on the Lock Side.
- If NFH < 96” V-Lock requires custom location.
- Fin-Pulls
 1. Actuator Height + 8”
 2. No Blade, Fin-Pulls will be at Actuator Height.
- Z- handle
 1. Fin-Pull “Yes”: Will match Fin-Pull location
 2. Fin-Pull “No”: Will match Actuator Height location.

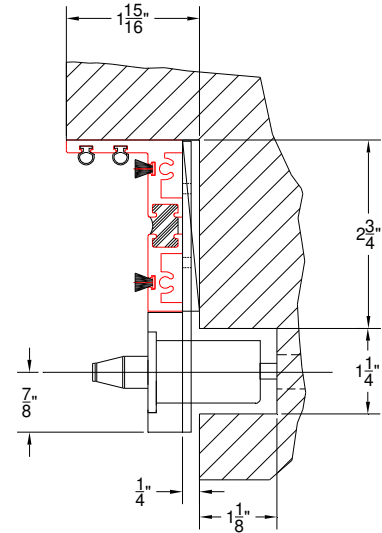

Figure D2:
Plan View V-Lock Knockout

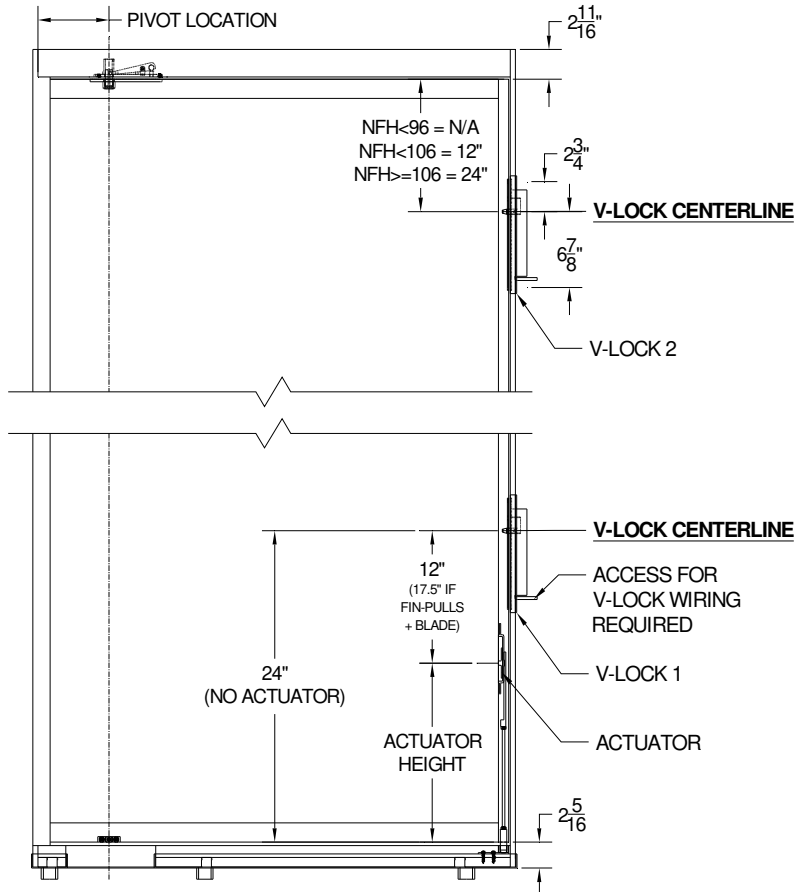

Figure D1:
Elevation View V-Lock 1 or 2 Locations

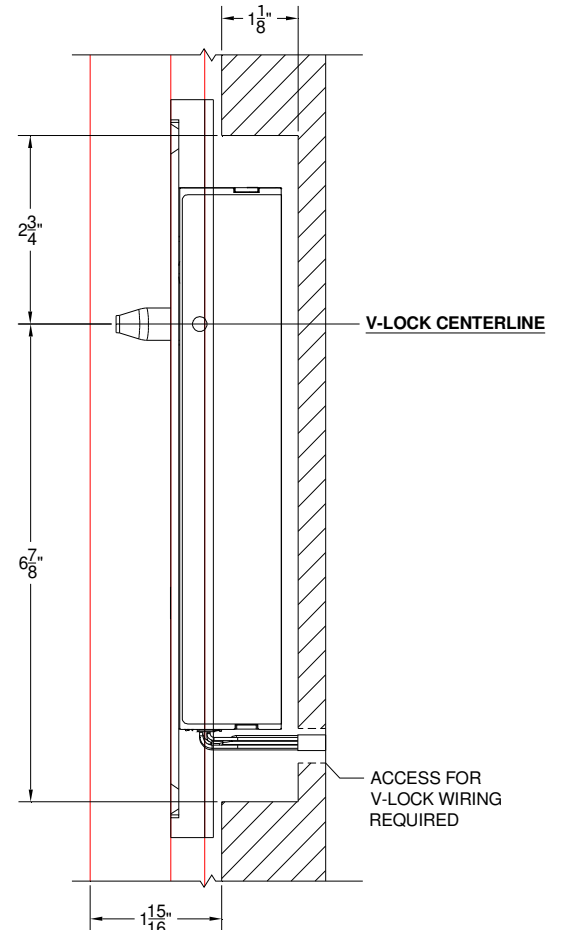

Figure D3:
Elevation View V-Lock Knockout

Appendix E: Mullion Installation

Note: Fixed Side Lites utilize the EDGE |f| O-GTF system. Refer to the EDGE |f| Installation Instructions for complete product-specific requirements.

1. Assemble and Install EDGE | f |
 - Assemble EDGE | f | unit(s).
 - Head and sill caps are to be used in place of the jamb, on the mullied side of the EDGE | p |.
 - Secure the head/sill caps with the provided fasteners
 - Install the EDGE | f | unit(s) accordingly.
 - Glaze the EDGE |f| using the provided setting blocks
 - Install a 1/8" setting block between the glass and the caps at the head/sill (Figure E1).
2. Assemble and Install EDGE |p|
 - Assemble the EDGE | p | according to the configuration purchased. There will be no jamb on the side with fixed lite(s).
 - A head cap will be installed in place of the jamb(s).
 - The EDGE | p | head is to be placed with a 1/16" gap between products and offset 5/16" from the backside of the EDGE | f | (Figure E2).
 - Fasten the head and bottom pivot accordingly.
 - Install the EDGE | p | panel.
3. Mullion Alignment / Installation
 - Test-fit the EDGE |p| mullion(s) between the head and sill of the EDGE |f|.
 - Confirm proper mullion orientation and alignment with the EDGE |p| panel.
 - Each mullion is supplied with 1" glass keys secured with silicone at the top and bottom to maintain proper positioning during glazing.
 - Ensure the mullion glass keys are firmly positioned against the glass (Figure E3).
 - Back-fill the mullion with structural sealant.

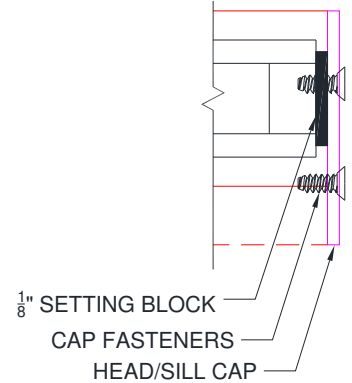

Figure E1:
EDGE | f | mullied detail

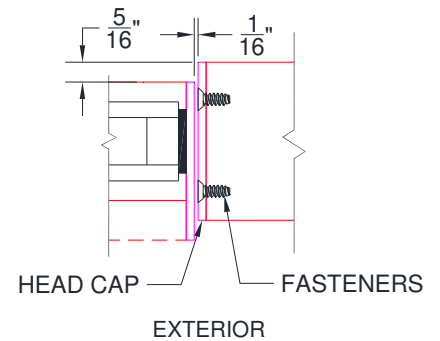
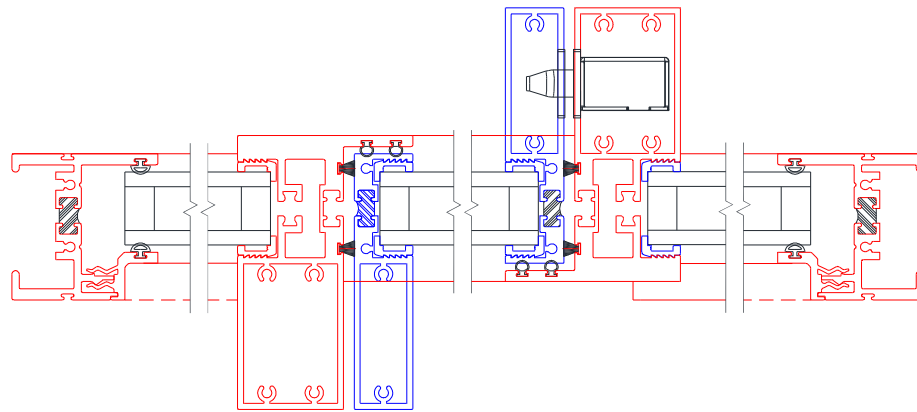

Figure E2:
EDGE | p | Placement



EXTERIOR
Figure E3:
EDGE | p | OHO Example

Appendix F: Handle Pull Options

Note: Handle Pull options must be made at time of purchase, otherwise replacement glass will be required.

Flush Pull
 (BLK)

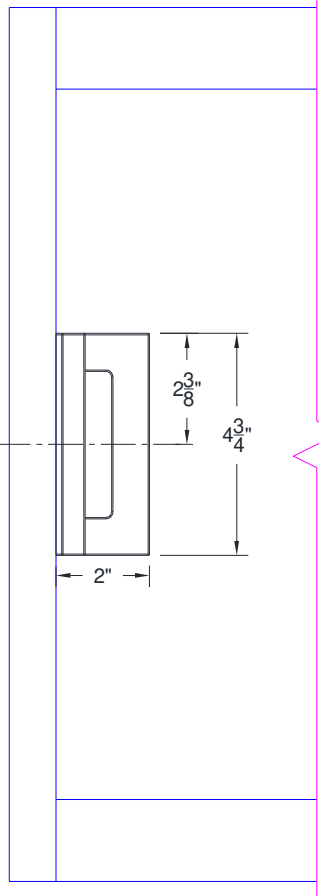
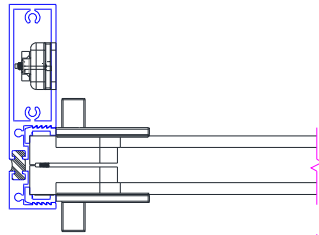

Brackets for 3rd Party Pull
 (SS/BLK)

