



ASTM E1886 and ASTM E1996 TEST REPORT

Report No.: E8390.02-301-18

Rendered to:
FLEETWOOD WINDOWS AND DOORS
Corona, California

PRODUCT TYPE: Sliding Door
SERIES/MODEL: 3070-T Corner Door/Pocket Door

This report contains in its entirety:

Cover Page: 1 page
Report Body: 11 pages
Sketch: 1 page
Drawings: 12 pages

Test Start Date: 07/16/15
Test End Date: 11/11/15
Report Date: 02/02/16
Revision 4 Date: 07/25/16
Test Record Retention End Date: 11/11/19

1.0 Client Identification:

1.1 Report Issued To: Fleetwood Windows & Doors

1 Fleetwood Way
Corona, California 92879

1.2 Contact Person: Joe Zammit

2.0 Laboratory Identification:

2.1 Test Laboratory: Architectural Testing, Inc., an Intertek company ("Intertek-ATI")

2524 East Jensen Avenue
Fresno, California 93706

2.2 Phone Number: (559) 233-8705

3.0 Project Summary:

3.1 Product Type: Sliding Door

3.2 Series/Model: 3070-T Corner Door/Pocket Door

3.3 Compliance Statement: Results obtained are tested values and were secured by using the designated test method(s). The specimen(s) tested met the performance requirements set forth in the referenced test procedures for a **+2400/-2640 Pa (+50.13/-55.14psf) Design Pressure** with missile impacts corresponding to Missile Level D and Wind Zone 4.

NOTE: One corner door sample tested. Reference test report E8392.02-301-18 for the flat door configuration with three samples tested as outlined in the ASTM E1996 test standard.

3.4 Test Dates: 07/16/15 - 11/11/15

3.5 Test Record Retention End Date: All test records for this report will be retained until November 11, 2019.

3.6 Test Location: Architectural Testing, Inc. test facility in Fresno, California.

3.7 Test Specimen Source: The test specimen(s) was provided by the client. Representative samples of the test specimen(s) will be retained by Architectural Testing for a minimum of four years from the test completion date.

3.8 Drawing Reference: The test specimen drawings have been reviewed by Architectural Testing and are representative of the test specimen(s) reported herein. Test specimen construction was verified by Architectural Testing per the drawings located in Appendix B. Any deviations are documented herein or on the drawings.

3.0 Project Summary: (Continued)

3.9 List of Official Observers:

<u>Name</u>	<u>Company</u>
Nathan Baker	Fleetwood
Dennis Janzen	Intertek-ATI
Tyler Westerling	Intertek-ATI

4.0 Test Protocol(s):

ASTM E1886-13a, Standard Test Method for Performance of Exterior Windows, Curtain Walls, Doors, and Impact Protective Systems Impacted by Missile(s) and Exposed to Cyclic Pressure Differentials

ASTM E1996-14a, Standard Specification for Performance of Exterior Windows, Curtain Walls, Doors, and Impact Protective Systems Impacted by Windborne Debris in Hurricanes

5.0 Test Specimen Description: (Continued)

5.1 Product Sizes:

Overall Area: 22.8 m ² (243 ft ²)	Width		Height	
	millimeters	inches	millimeters	inches
MAX Pocket wall size	4,572	180	3,048	120
MAX 90 Degree Corner wall size	4,572	180	3,048	120
MAX 135 Degree Corner wall size	3,048	120	3,048	120
MAX Panel size	1,588	62-1/16	2,997	118

The following descriptions apply to all specimens.

5.2 Frame Construction:

Frame Member	Material	Description
Sill	Thermally Broken Aluminum	Three piece sill
Sill pan	Aluminum	With a 3" tall interior leg
Sill filler	Aluminum	Snapped in place where panels do not slide
Jamb	Thermally Broken Aluminum	With snapped in jamb filler where panel is not engaged
Head	Thermally Broken Aluminum	With snapped in head filler where panel is not engaged

	Joinery Type	Detail
All corners	Butt	Sealed with silicone. Top corners fastened with one #10 x 2" Phillips head screw each. Bottom corners fastened with one #10 x 2". Two 1/4-20 x 1" Phillips head screws were fastened into each roller.

5.0 Test Specimen Description: (Continued)

5.3 Panel Construction:

Panel Member	Material	Description
All	Thermally Broken Aluminum	See drawings for details.

	Joinery Type	Detail
All corners	Butt	Sealed with silicone. Top corners fastened with two #8 x 3.5" Phillips head screw each. Bottom corners fastened with two #8 x 3.5" and two 1/4-20 x 1" Phillips head screw.

5.4 Weatherstripping:

Description	Quantity	Location
0.230 polypile with center fin	4	In sill contracting interior and exterior of each panel leg
0.230 polypile with center fin	2	In head contracting interior and exterior of panel face
0.290 Polypile with center fin	1	In each pocket interlock extrusion
0.230 polypile with center fin	2	In interior and exterior meeting stile locking extrusion.
0.290 polypile with center fin	1	In each interlock extrusion
Q-lon foam seal	1	In interior and exterior of jamb extrusion
Panel corner air barrier	1	At each exposed panel bottom and top corner.

5.0 Test Specimen Description: (Continued)

5.5 Glazing: *No conclusions of any kind regarding the adequacy or inadequacy of the glass in any glazed test specimen(s) can be made.*

Glass Type	Glazing	Glazing Method
IG	1/4" temp/air space/ lami (5/32" HS .090SGP 5/32: HS)	Channel glazed into frame. Dry glazed at all top and bottom rails and interlocks. Wet glazed at locking vertical stiles only

Location	Quantity	Daylight Opening		Glass Bite
		millimeters	inches	
All Lights	8	1435 x 2845	56-1/2 x 112	5/8

5.6 Drainage:

Drainage Method	Size	Quantity	Location
Weep Notch	1" wide by 3/16" tall	6	6" from the end of each sill member

5.7 Hardware:

Description	Quantity	Location
Rollers, Tandem	2 tandem rollers each panel	Bottom panel rail
Archetype narrow Lock	2	Locking meeting panel
Archetype II lock	1	Locking meeting panel

5.8 Reinforcement:

Drawing Number	Location	Material
37	All small interlock hallows	Aluminum
38	All small interlock hallows	Aluminum

5.9 Screen Construction: No screen was utilized.

6.0 Installation:

The specimen was installed into a Pine wood buck. The rough opening allowed for a 1/4" shim space. The exterior perimeter of the window was sealed with sealant. See drawing on sheet 8 of 12 for installation details.

7.0 Test Results: The temperature during testing was 65°F. Results are tabulated as follows:

ASTM E1886, Large

7.1 Protocol TAS 201-94, Large Impact Procedures

Conditioning Temperature: 18°C (65°F)

Missile Weight: 4080 g (9.0 lbs)

Missile Length: 2.4 m (8'0")

Muzzle Distance from Test Specimen: 5.2 m (17' 0")

Test Unit #1: Orientation within ±5° of horizontal

Impact #1: Missile Velocity: 15.5 m/s (50.9 fps)	
Impact Area:	Top left corner of jamb panel
Observations:	Missile hit target area
Results:	Pass

Impact #2: Missile Velocity: 15.4 m/s (50.6 fps)	
Impact Area:	Center of jamb panel
Observations:	Missile hit target area
Results:	Pass

Impact #3: Missile Velocity: 15.3 m/s (50.1 fps)	
Impact Area:	Center of center panel between 135 degree corner and jamb
Observations:	Missile hit target area
Results:	Pass

Impact #4: Missile Velocity: 15.2 m/s (49.8 fps)	
Impact Area:	Lower right corner of center panel between 135 degree corner and jamb
Observations:	Missile hit target area
Results:	Pass

Impact #5: Missile Velocity: 15.2 m/s (49.9 fps)	
Impact Area:	Center of vertical stile of 135 degree corner
Observations:	Missile hit target area
Results:	Pass

7.0 Test Results: (Continued)

7.1 Protocol TAS 201-94, Large Impact Procedures (Continued)

Test Unit #1: Orientation within $\pm 5^\circ$ of horizontal (Continued)

Impact #6: Missile Velocity: 15.3 m/s (50.2 fps)	
Impact Area:	Center of corner panel next to 135 degree meeting stile
Observations:	Missile hit target area
Results:	Pass

Impact #7: Missile Velocity: 15.0 m/s (49.1fps)	
Impact Area:	Top right corner of corner panel next to 135 degree meeting stile
Observations:	Missile hit target area
Results:	Pass

Impact #8: Missile Velocity: 15.0 m/s (49.3 fps)	
Impact Area:	Center of right hand vertical stile of the center panel between 90 and 135 degree corners
Observations:	Missile hit target area
Results:	Pass

Impact #9: Missile Velocity: 15.0 m/s (49.3 fps)	
Impact Area:	Center of panel to the right of 90 degree corner
Observations:	Missile hit target area
Results:	Pass

Impact #10: Missile Velocity: 15.1 m/s (49.6 fps)	
Impact Area:	Lower left corner of panel to the right of 90 degree corner
Observations:	Missile hit target area
Results:	Pass

Impact #9: Missile Velocity: 15.2 m/s (49.9 fps)	
Impact Area:	Center of 90 degree corner stile
Observations:	Missile hit target area
Results:	Pass

7.0 Test Results: (Continued) The temperature during ASTM E1886 testing was 65°F. Results are tabulated as follows:

ASTM E1886, Air Pressure Cycling

Test Unit #1

Design Pressure: a +2640/-2880 Pa (+50/-55psf)

POSITIVE PRESSURE

Pressure Range (psf)	Number of Cycles	Average Cycle Time (seconds)	Observations
10 to 25	3500	2.61	
0 to 30	300	4.89	
25 to 40	600	2.58	
15 to 50	100	4.91	

NEGATIVE PRESSURE

Pressure Range (psf)	Number of Cycles	Average Cycle Time (seconds)	Observations
16.5 to 55	50	4.96	
27.5 to 44	1050	3.22	
0 to 33	50	4.77	
11 to 27.5	3350	2.83	

Result: Pass

Conclusion: Intertek-ATI observed no signs of failure in any area of the test specimens during the cyclic load test; as such, the test specimens satisfy the cyclic load requirements of TAS 203.

8.0 Test Equipment:

Cannon: Constructed from steel piping utilizing compressed air to propel the missile

Missile: 2x4 Southern Pine

Timing Device: Electronic beam type

Cycling Mechanism: Computer controlled centrifugal blower with electronic pressure measuring device

Deflection Measuring Device: Linear transducers

Laboratory Compliance Statements: The following are provided as required by the protocols for the testing reported herein:

Upon completion of testing, specimens tested for TAS 201-94 met the requirements of Section 1626 of the Florida Building Code, Building.

AND

Upon completion of testing, specimens tested for TAS 202-94 met the requirements of Section 1620 of the Florida Building Code, Building.

AND

Upon completion of testing, specimens tested for TAS 203-94 met the requirements of Section 1626 of the Florida Building Code, Building.

Tape and film were used to seal against air leakage during structural testing. In our opinion, the tape and film did not influence the results of the test.

Intertek-ATI will service this report for the entire test record retention period. Test records such as detailed drawings, datasheets, representative samples of test specimens, or other pertinent project documentation, will be retained by Intertek-ATI for the entire test record retention period.

This report does not constitute certification of this product nor an opinion or endorsement by this laboratory. It is the exclusive property of the client so named herein and relates only to the specimen(s) tested. This report may not be reproduced, except in full, without the written approval of Intertek-ATI.

For ARCHITECTURAL TESTING, INC.:

Dennis Janzen
Technician

Tyler Westerling, P.E.
Senior Project Engineer

TW:ss

Attachments (pages): This report is complete only when all attachments listed are included.

Appendix A: Sketches (1)

Appendix B: Drawings (12)

This report produced from controlled document template ATI 00651, revised 07/08/15.

Revision Log

Rev. #	Date	Page(s)	Revision(s)
0	02/02/16	N/A	Original report issue.
1	02/09/16	Appendix B	Revised drawings.
2	05/02/16	4	Corrected panel corner detail.
2	05/02/16	3	Corrected installation details.
2	05/02/16	Appendix B	Updated drawing package.
3	07/13/16	Appendix B	Updated drawing package.
4	07/25/16	5	Revised glazing description.

This report produced from controlled document template ATI 00651, revised 07/08/15.

Appendix A

Sketch

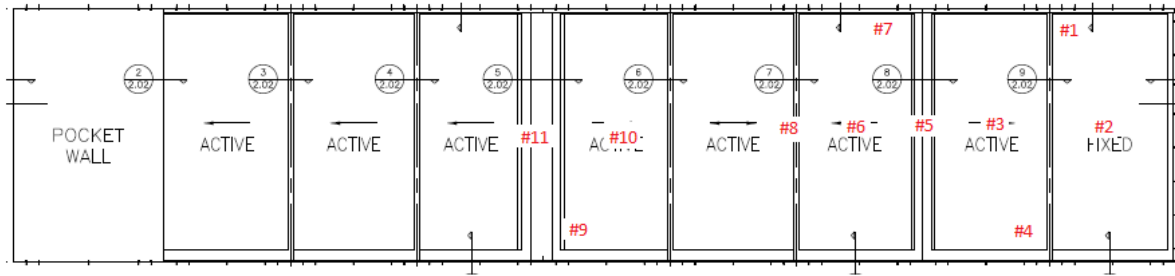

Sketch #1 Impact Locations



Test Report No.: E8390.02-301-18
Revision 4 Date: 07/25/16

Appendix B

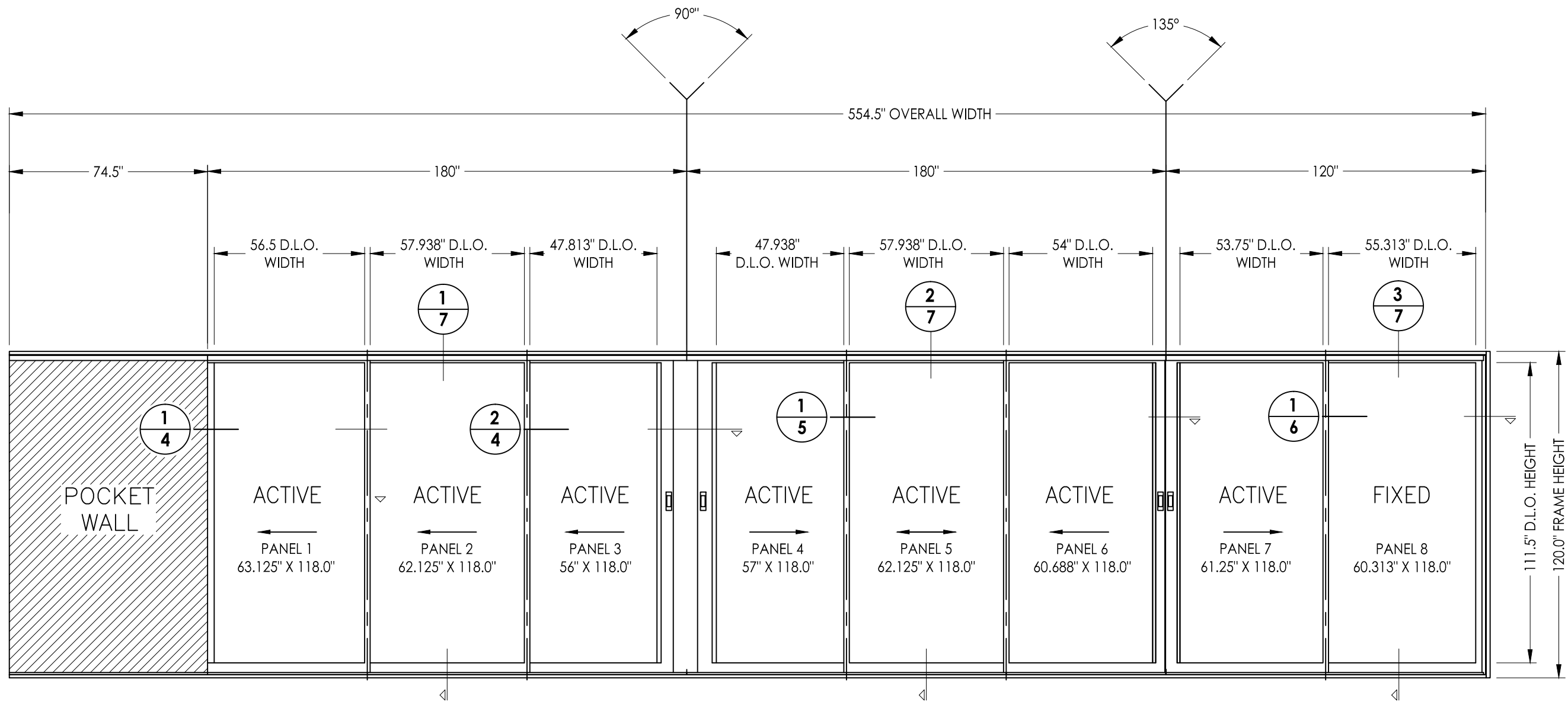

Drawings



TEST ELEVATION (SILL PAN NOT SHOWN)

 Report #: E8390-301-18
 Date: 07/13/16
 Verified by: *[Signature]*

TABLE OF CONTENTS	
SHEET #	DESCRIPTION
1	Table of contents and test elevation
2	Panel details
3	Panel details
4	Horizontal cross section
5	Horizontal cross section
6	Horizontal cross section
7	Vertical cross sections
8	Frame anchoring
9	Hardware components
10	Hardware components
11	Components
12	Bill of materials, components and glazing details

REVISIONS	DATE	DRAWN BY	COMMENTS
REV-1	6/28/16	BL	UPDATED GLASS
DATE: 6/22/15		JOB NUMBER: 385199-V2	
MATERIAL: SERIES 3070-T		CUSTOMER: FLEETWOOD WINDOWS AND DOORS	
JOB NAME: FLEETWOOD TAS & AAMA TEST		JOB NUMBER: 385199-V2	
			
			
SCALE: DO NOT SCALE			
DRAWING NO.: 1			
SHEET: 1 OF 12			

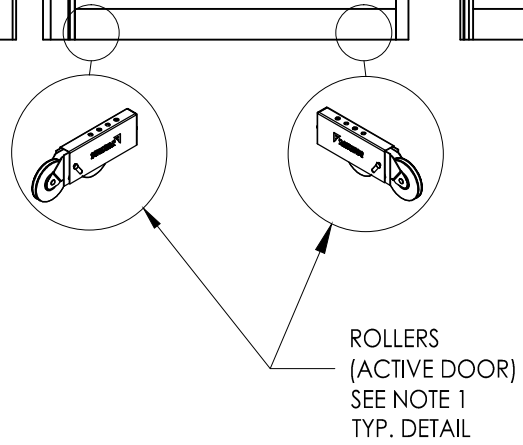
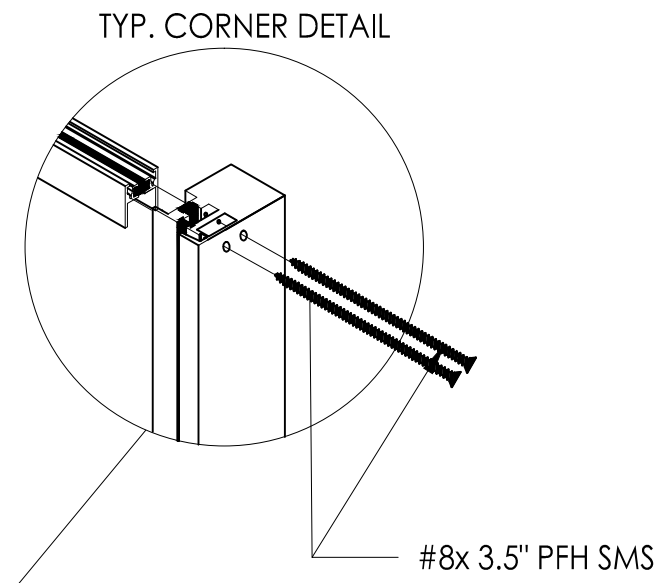
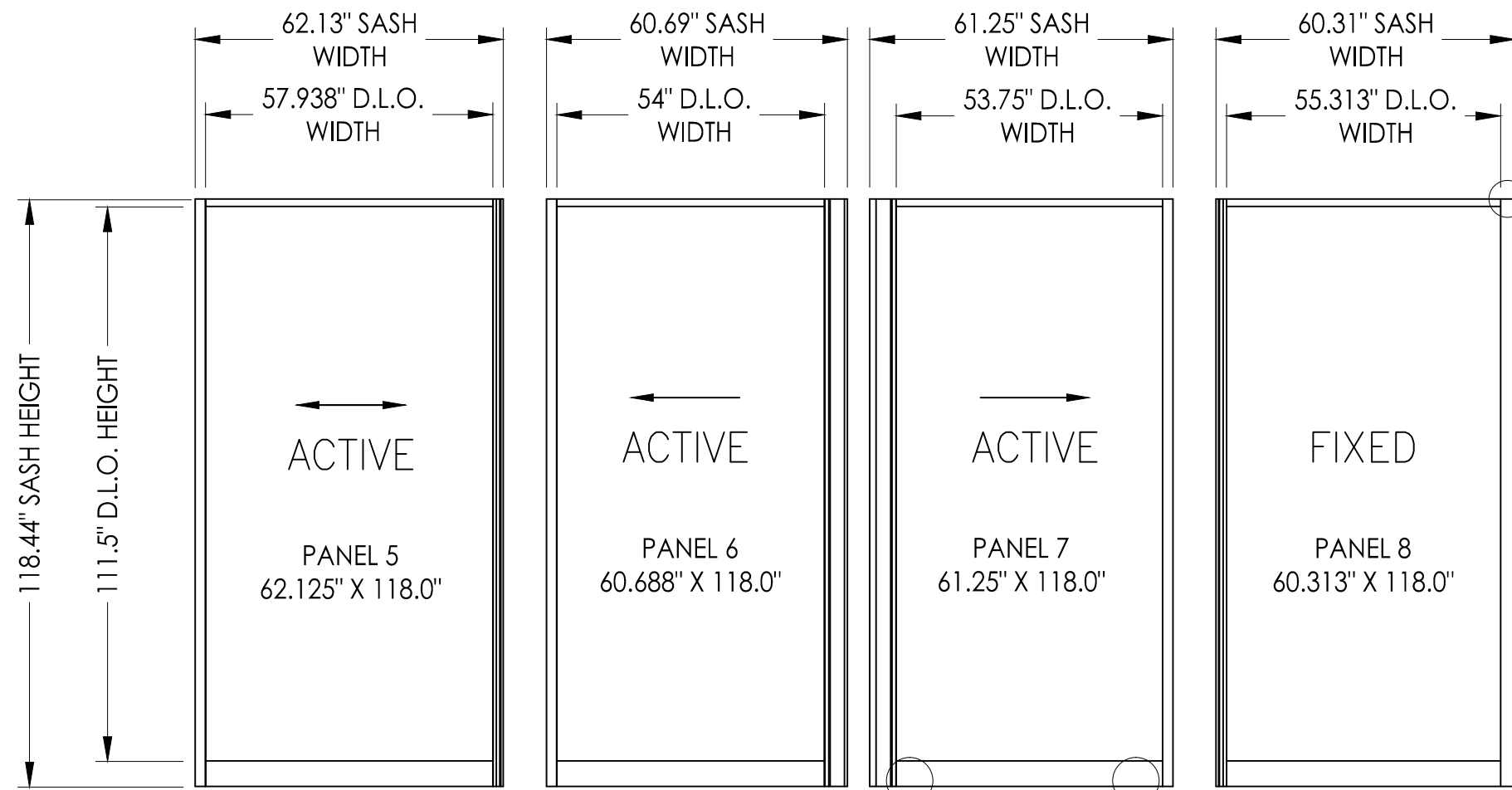

Intertek	Report #:	E8390-301-18
	Date:	07/13/16
	Verified by:	<i>[Signature]</i>

Note:
 1. Roller attached to bottom rail utilizing (2) 1/4-20 x 1/2" PFH Screw and attached to Stile utilizing (2) 1/4 -20 x 1" PPH Screw.

REVISIONS	DATE	DRAWN BY	COMMENTS
REV-1	6/28/16	BL	UPDATED GLASS
DATE:		JOB NUMBER:	
6/22/15		385199-V2	
MATERIAL: SERIES 3070-T		CUSTOMER: FLEETWOOD WINDOWS AND DOORS	
JOB NAME: FLEETWOOD TAS & AAMA TEST			
FLEETWOOD WINDOWS AND DOORS 1 FLEETWOOD WAY CORONA, CALIFORNIA 92709 - www.fleetwoodusa.com			
SCALE: DO NOT SCALE			
DRAWING NO.: 3			
SHEET: 3 OF 12			

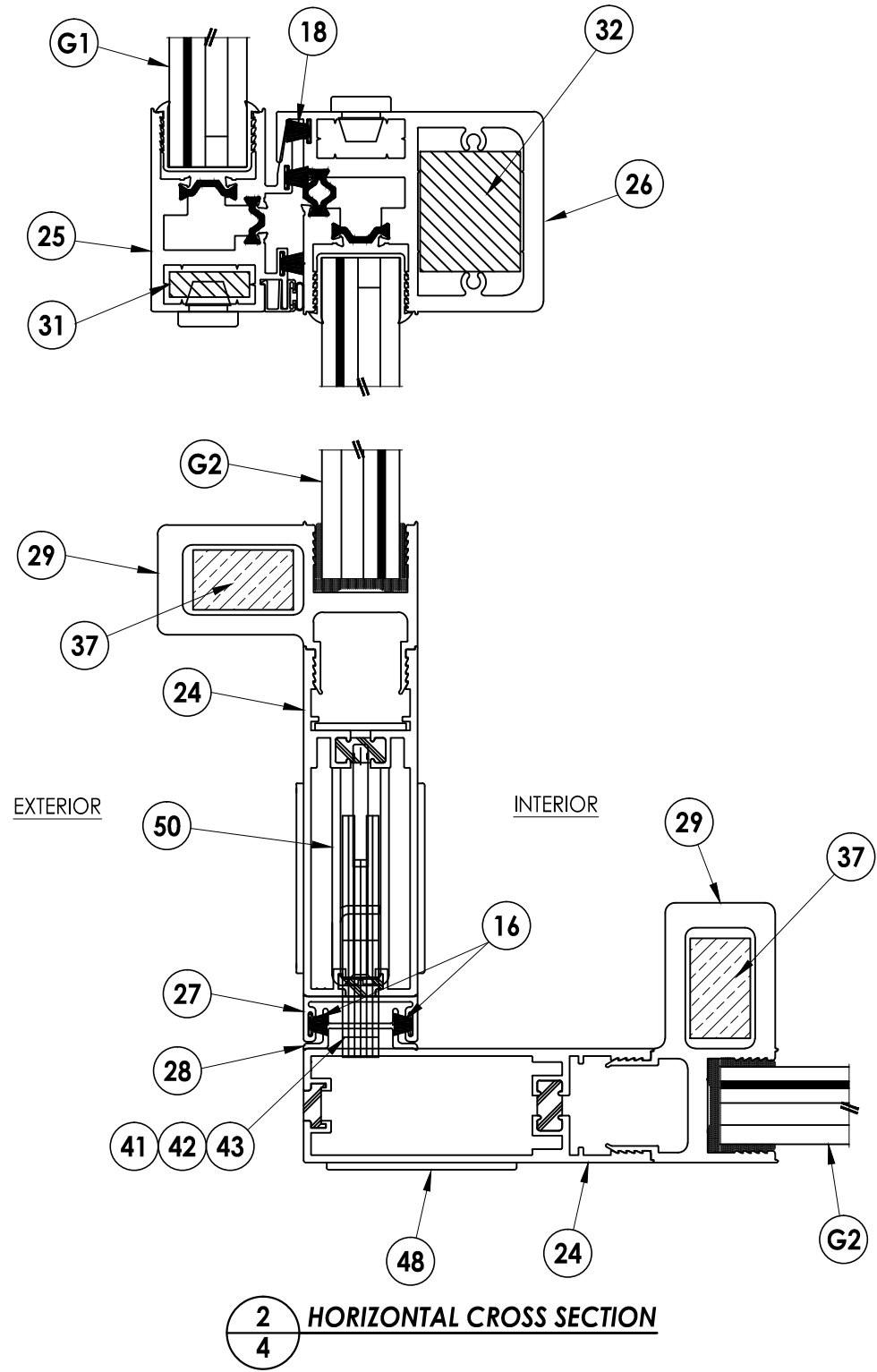
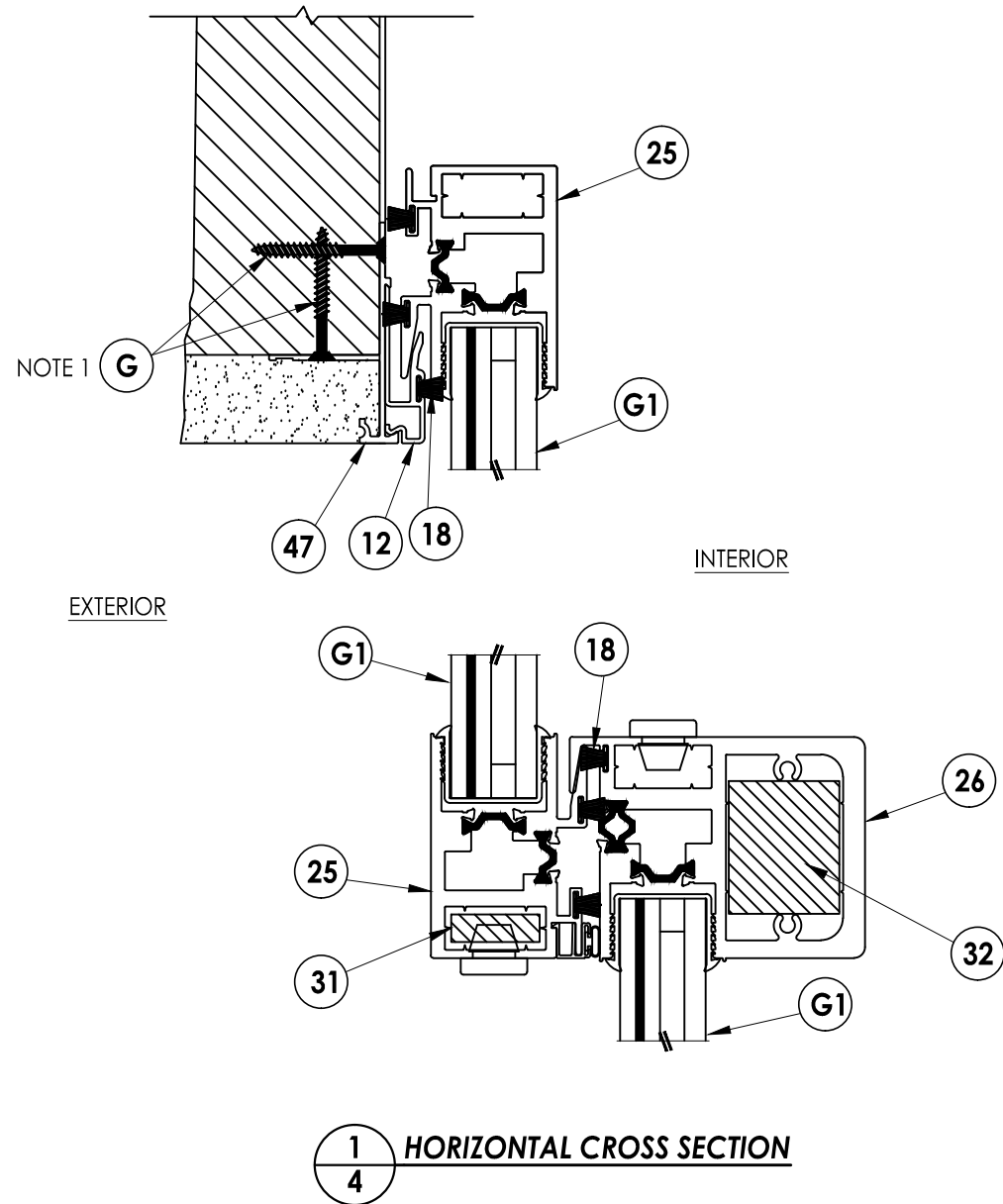

NOTE:
1.8" from each end then 12" on center

Intertek

Report #: E8390-301-18

Date: 07/13/16

Verified by: *[Signature]*

MATERIAL:	SERIES 3070-T	DATE:	6/22/15	REVISIONS:	REV-1	COMMENTS:	UPDATED GLASS
CUSTOMER:	FLEETWOOD WINDOWS AND DOORS	DRAWN BY:	BL	DATE:	6/28/16	DRAWN BY:	BL
JOB NAME:	FLEETWOOD TAS & AAMA TEST	JOB NUMBER:	385199-V2	REVISIONS:	REV-1	COMMENTS:	
<p>FLEETWOOD WINDOWS AND DOORS <small>1 FLEETWOOD WAY CORONA, CALIFORNIA 92709 - WWW.FLEETWOODUSA.COM</small></p>							
<p>SCALE: DO NOT SCALE</p>							
<p>DRAWING NO.: 4</p>							
<p>SHEET: 4 OF 12</p>							

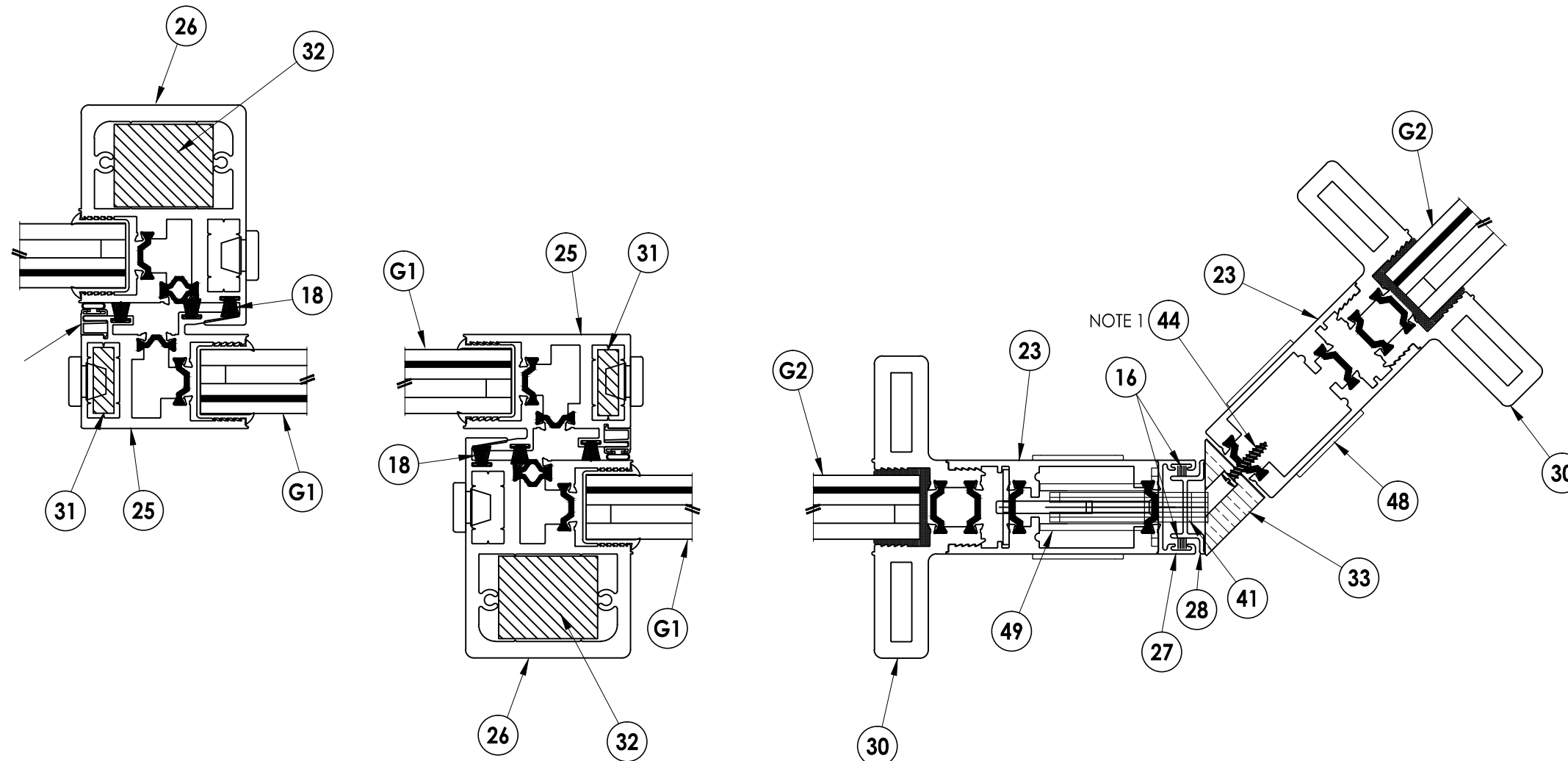

1
5 HORIZONTAL CROSS SECTION

NOTE:
1. 6" from each end then 18" on center

Intertek	Report #:	E8390-301-18
	Date:	07/13/16
	Verified by:	<i>[Signature]</i>

MATERIAL:	SERIES 3070-T	DRAWN BY:	BL	DATE:	6/22/15	REVISIONS:	REV-1	DATE:	6/28/16	DRAWN BY:	BL	COMMENTS:	UPDATED GLASS
CUSTOMER:	FLEETWOOD WINDOWS AND DOORS	JOB NUMBER:	385199-V2										
JOB NAME:	FLEETWOOD TAS & AAMA TEST												

FLEETWOOD
WINDOWS AND DOORS
1 FLEETWOOD WAY CORONA, CALIFORNIA 92709 - www.fleetwoodusa.com

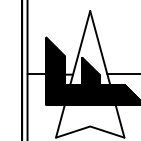

SCALE:
DO NOT SCALE

DRAWING NO.:
5

SHEET:
5 OF 12

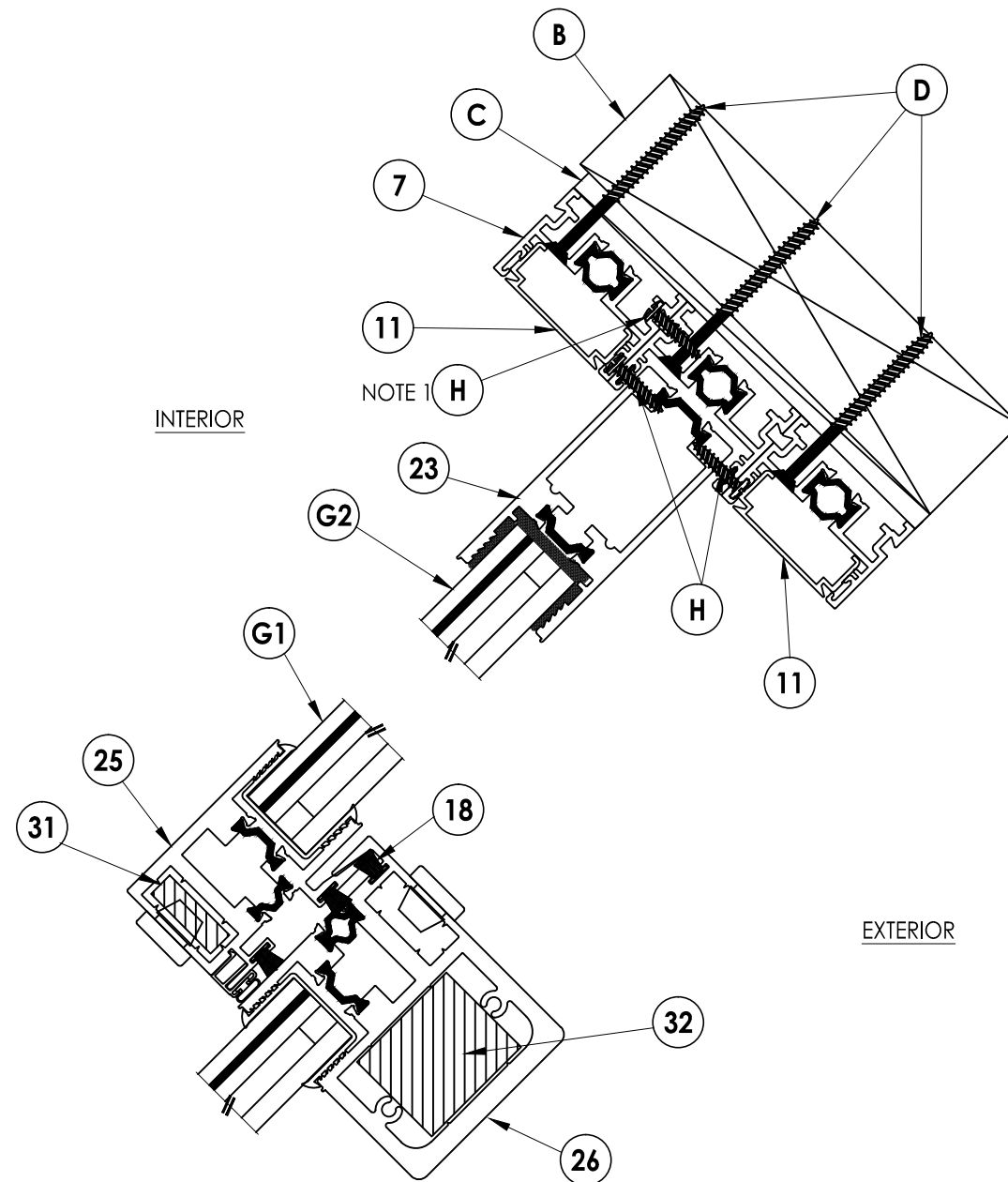

1
6 **HORIZONTAL CROSS SECTION**

- NOTE:
1. 1" from each end then 60" on center
 2. Interior or exterior (gasket cut 2" from top rail and bottom rail on stile).

Intertek	Report #:	E8390-301-18
	Date:	07/13/16
	Verified by:	<i>[Signature]</i>

MATERIAL: SERIES 3070-T		DATE:	6/22/15	REVISIONS:	REV-1	DATE:	6/28/16	DRAWN BY:	BL	COMMENTS:	UPDATED GLASS
CUSTOMER: FLEETWOOD WINDOWS AND DOORS		JOB NUMBER:		JOB NAME:		JOB NUMBER:		JOB NAME:		JOB NUMBER:	
JOB NAME: FLEETWOOD TAS & AAMA TEST		JOB NUMBER: 385199-V2		JOB NAME: FLEETWOOD TAS & AAMA TEST		JOB NUMBER: 385199-V2		JOB NAME: FLEETWOOD TAS & AAMA TEST		JOB NUMBER: 385199-V2	
<p>FLEETWOOD WINDOWS AND DOORS <small>1 FLEETWOOD WAY CORONA, CALIFORNIA 92709 - www.fleetwoodusa.com</small></p>											
SCALE: DO NOT SCALE											
DRAWING NO.: 6											
SHEET: 6 OF 12											

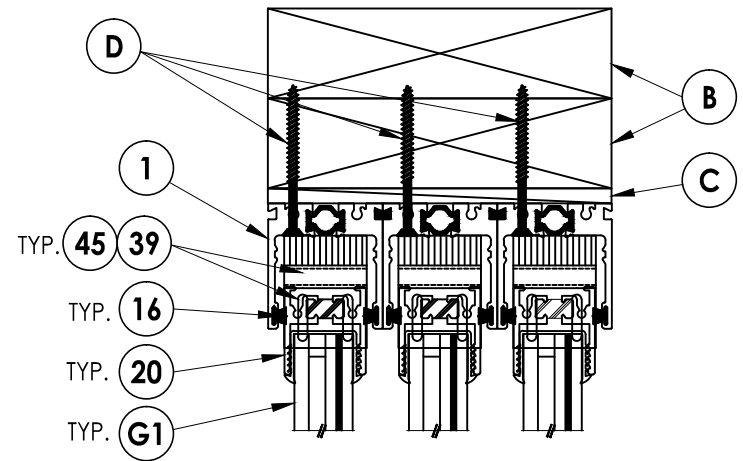

EXTERIOR

INTERIOR

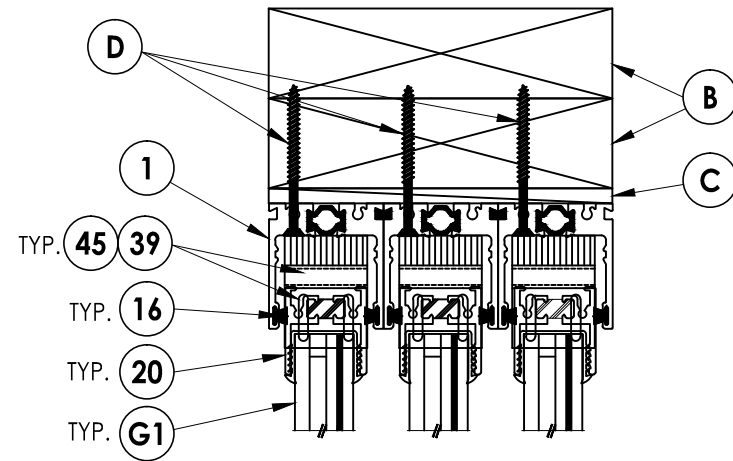

EXTERIOR

INTERIOR

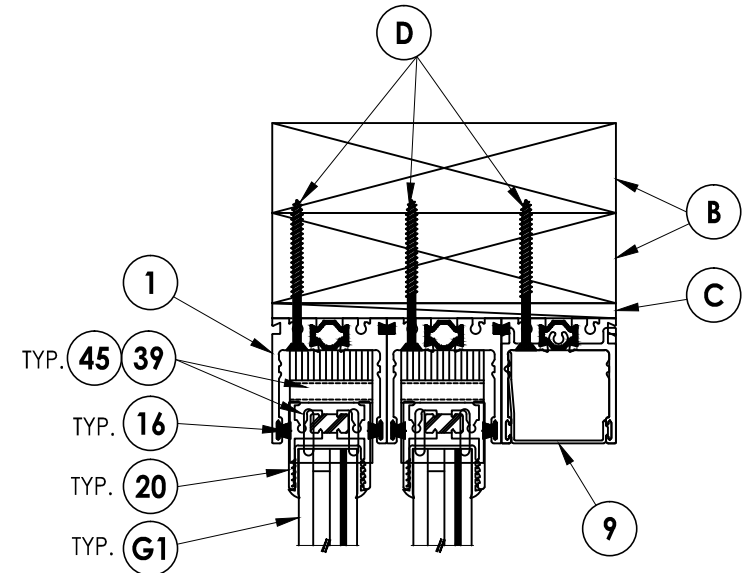

EXTERIOR

INTERIOR

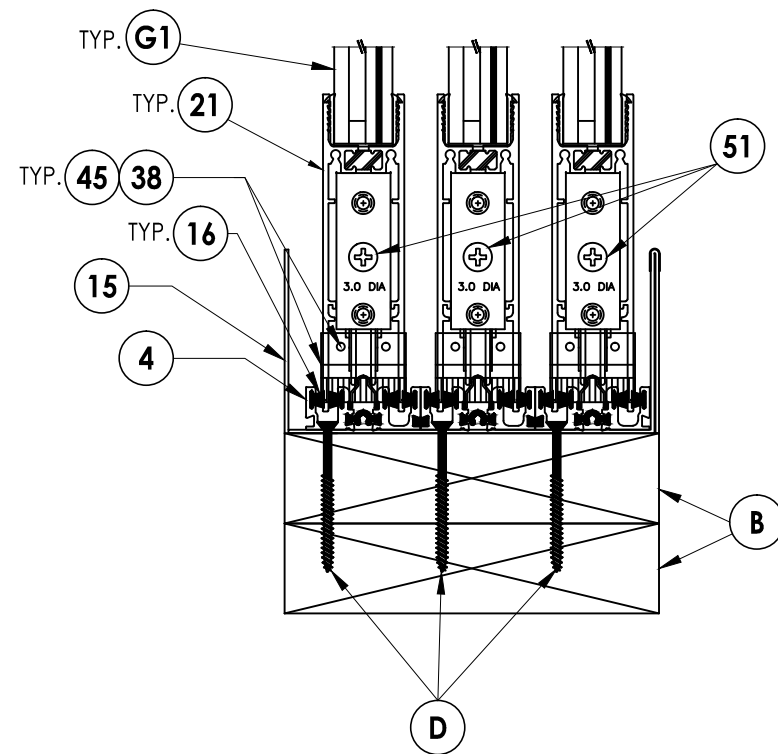

1 VERTICAL CROSS SECTION
7

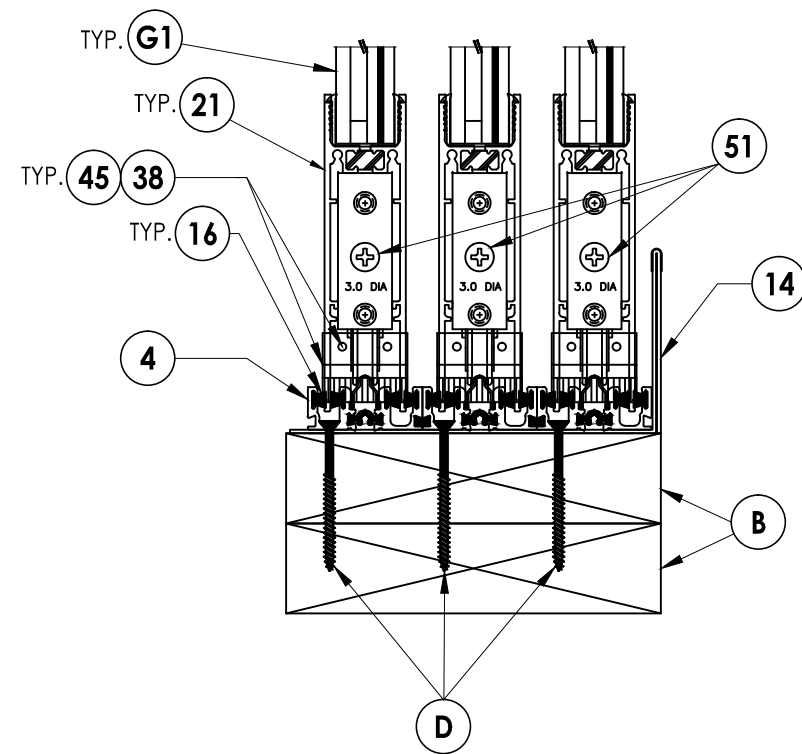

2 VERTICAL CROSS SECTION
7

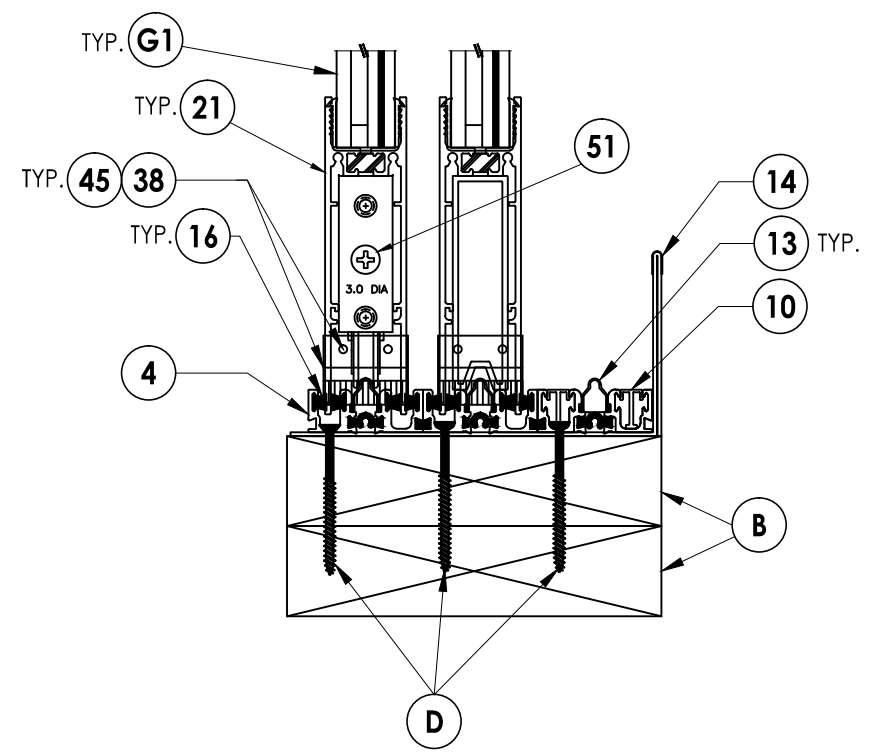

3 VERTICAL CROSS SECTION
7

COMMENTS	UPDATED GLASS
DRAWN BY	BL
DATE	6/28/16
REVISIONS	REV-1
DATE:	6/22/15
DRAWN BY:	BL
JOB NUMBER:	385199-V2
MATERIAL:	SERIES 3070-T
CUSTOMER:	FLEETWOOD WINDOWS AND DOORS
JOB NAME:	FLEETWOOD TAS & AAMA TEST
 FLEETWOOD WINDOWS AND DOORS 1 FLEETWOOD WAY CORONA, CALIFORNIA 92709 - www.fleetwoodusa.com	
SCALE ↓ DO NOT SCALE	
DRAWING NO. : 7	
SHEET : 7 OF 12	

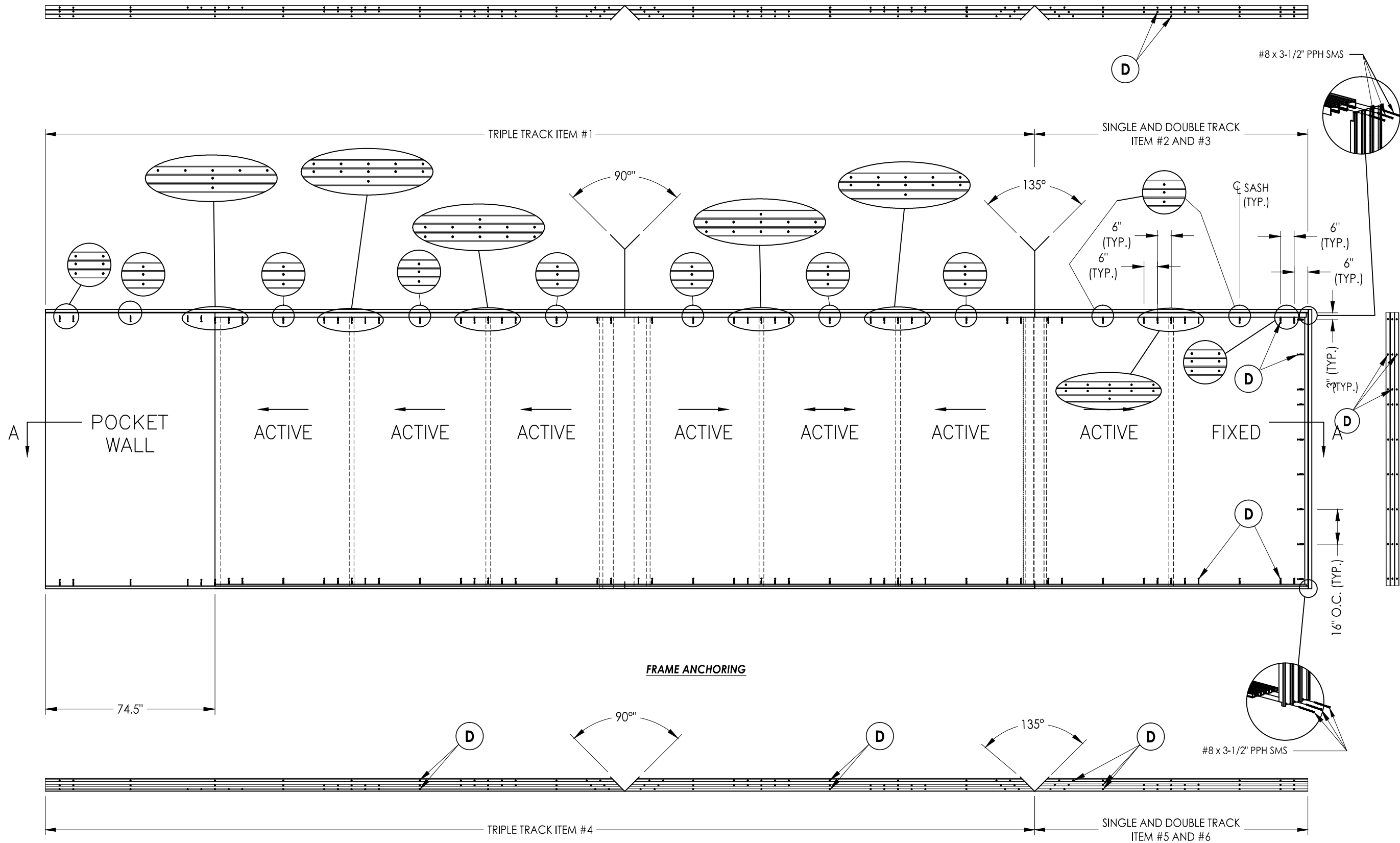

FRAME ANCHORING

SECTION A-A

	Report #:	E8390-301-18
	Date:	07/13/16
	Verified by:	<i>[Signature]</i>

COMMENTS	UPDATED GLASS
DRAWN BY	BL
DATE	6/28/16
REVISIONS	REV-1
DATE:	6/22/15
DRAWN BY:	BL
JOB NUMBER:	385199-V2
MATERIAL:	SERIES 3070-T
CUSTOMER:	FLEETWOOD WINDOWS AND DOORS
JOB NAME:	FLEETWOOD TAS & AAMA TEST
SCALE	DO NOT SCALE
DRAWING NO.:	8
SHEET	8 OF 12

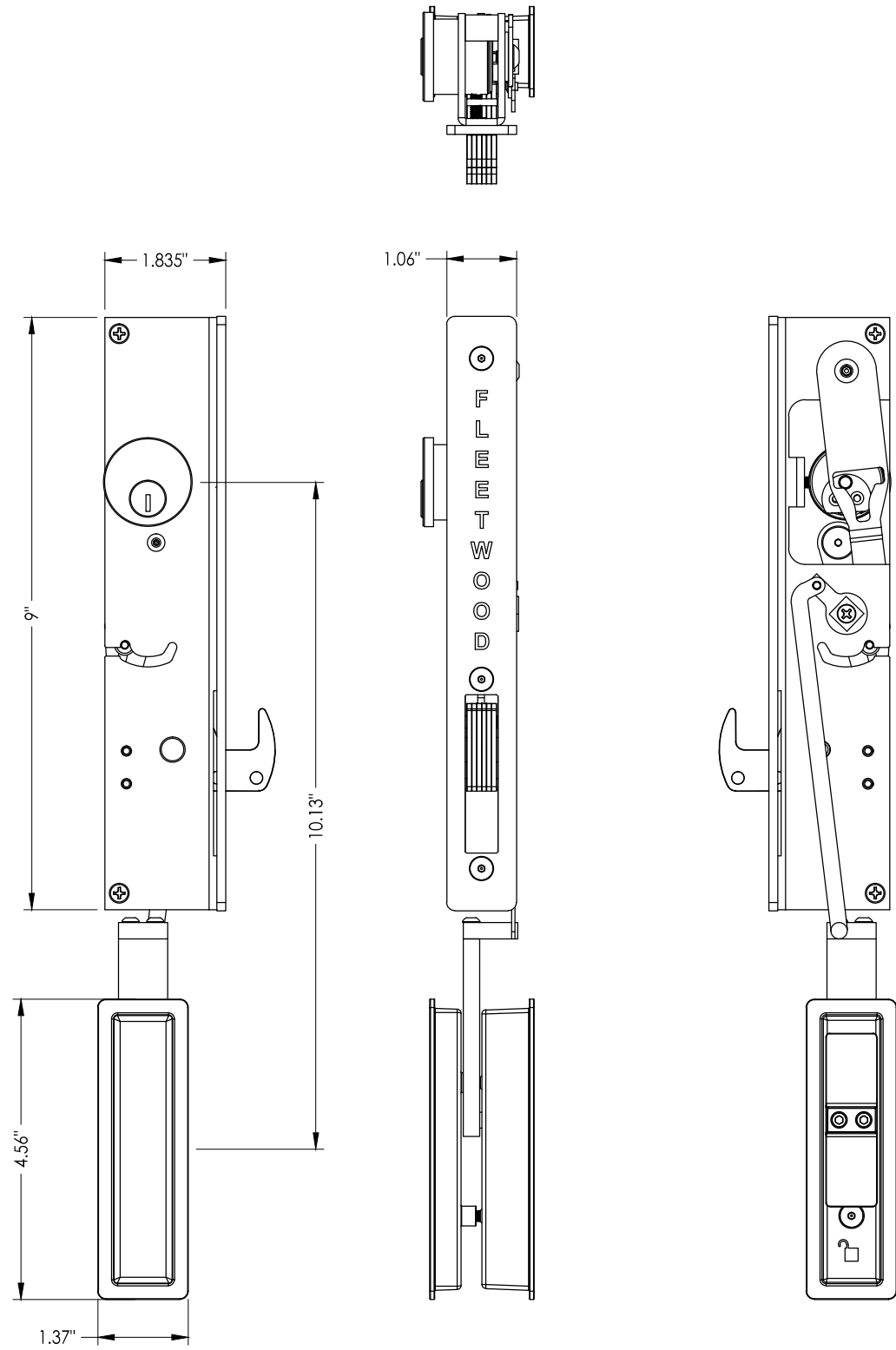

49 ARCHETYPE NARROW LOCK

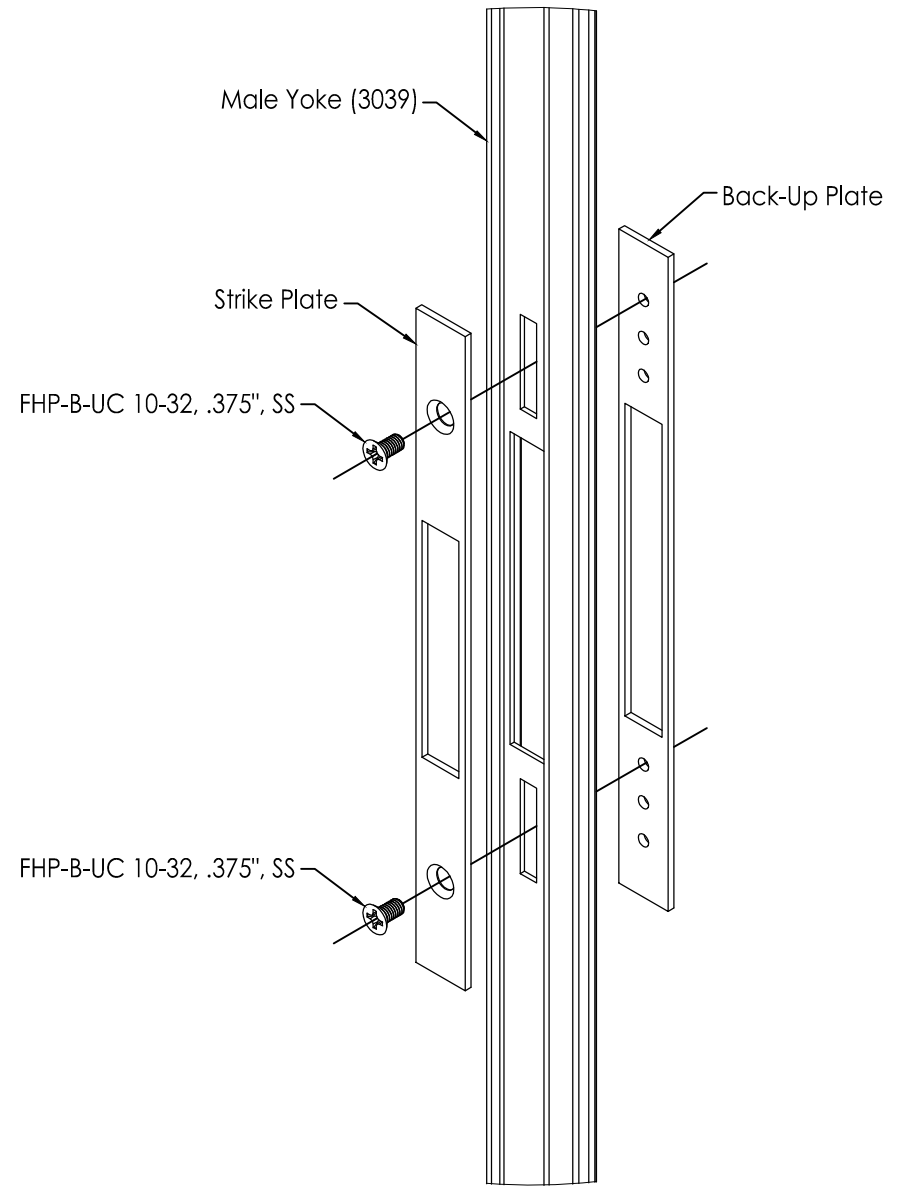
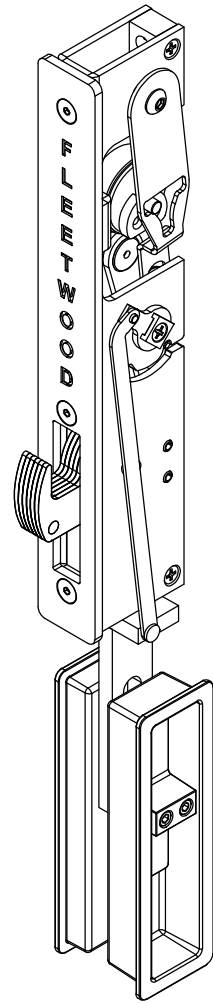

41 STRIKE PLATE

 Report #: E8390-301-18
 Date: 07/13/16
 Verified by: *[Signature]*

MATERIAL: SERIES 3070-T		DATE: 6/22/15	REVISIONS: REV-1	DATE: 6/28/16	DRAWN BY: BL	COMMENTS: UPDATED GLASS
CUSTOMER: FLEETWOOD WINDOWS AND DOORS		DATE: 6/22/15	REVISIONS: REV-1	DATE: 6/28/16	DRAWN BY: BL	COMMENTS: UPDATED GLASS
JOB NAME: FLEETWOOD TAS & AAMA TEST		DATE: 6/22/15	REVISIONS: REV-1	DATE: 6/28/16	DRAWN BY: BL	COMMENTS: UPDATED GLASS
JOB NUMBER: 385199-V2		DATE: 6/22/15	REVISIONS: REV-1	DATE: 6/28/16	DRAWN BY: BL	COMMENTS: UPDATED GLASS
FLEETWOOD WINDOWS AND DOORS		DATE: 6/22/15	REVISIONS: REV-1	DATE: 6/28/16	DRAWN BY: BL	COMMENTS: UPDATED GLASS
1 FLEETWOOD WAY CORONA, CALIFORNIA 92709 - www.fleetwoodusa.com		DATE: 6/22/15	REVISIONS: REV-1	DATE: 6/28/16	DRAWN BY: BL	COMMENTS: UPDATED GLASS
FLEETWOOD		DATE: 6/22/15	REVISIONS: REV-1	DATE: 6/28/16	DRAWN BY: BL	COMMENTS: UPDATED GLASS
WINDOWS AND DOORS		DATE: 6/22/15	REVISIONS: REV-1	DATE: 6/28/16	DRAWN BY: BL	COMMENTS: UPDATED GLASS
SCALE: DO NOT SCALE		DATE: 6/22/15	REVISIONS: REV-1	DATE: 6/28/16	DRAWN BY: BL	COMMENTS: UPDATED GLASS
DRAWING NO. 9		DATE: 6/22/15	REVISIONS: REV-1	DATE: 6/28/16	DRAWN BY: BL	COMMENTS: UPDATED GLASS
SHEET 9 OF 12		DATE: 6/22/15	REVISIONS: REV-1	DATE: 6/28/16	DRAWN BY: BL	COMMENTS: UPDATED GLASS

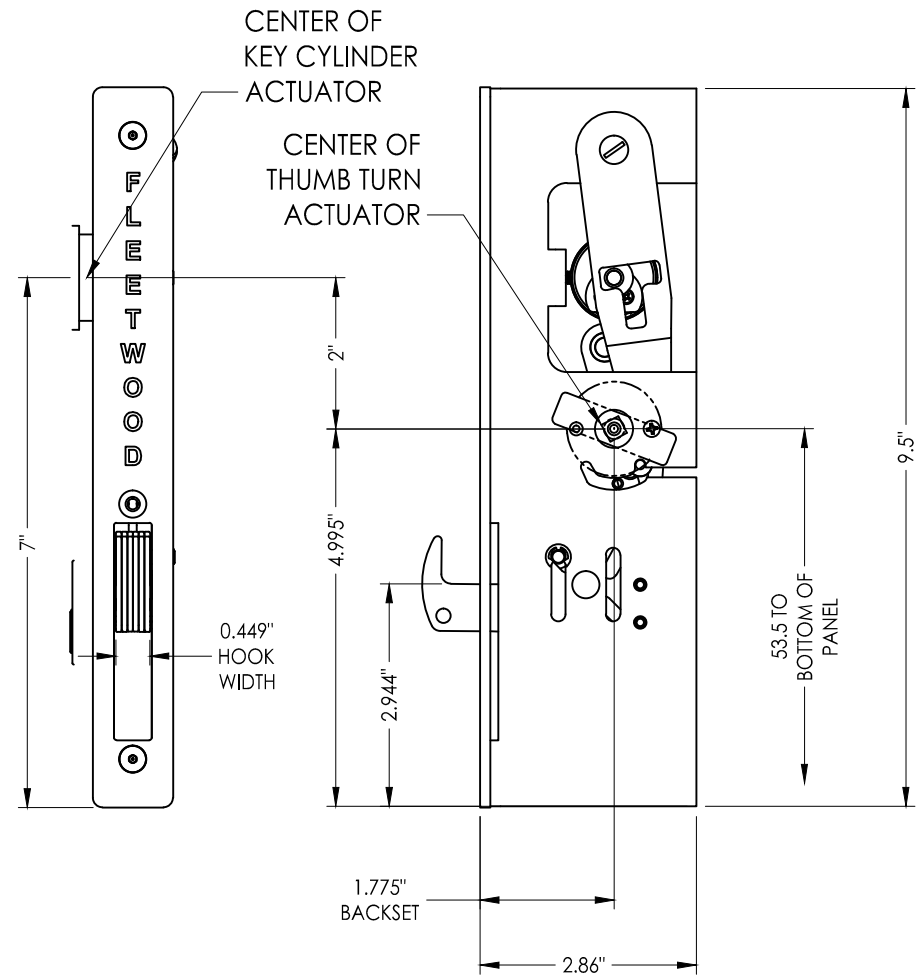

50 ARCHETYPE LOCK

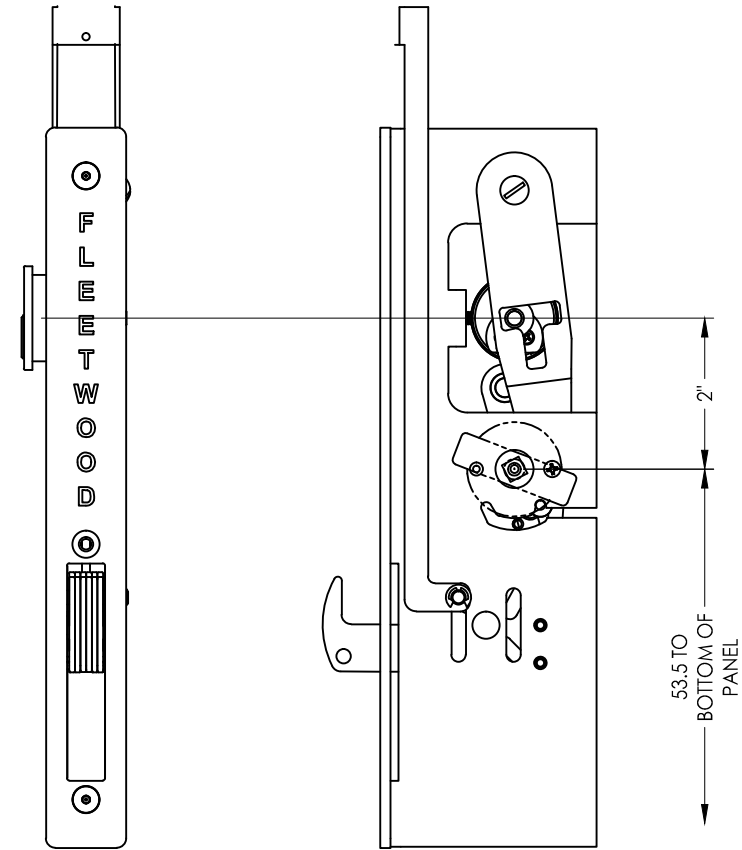
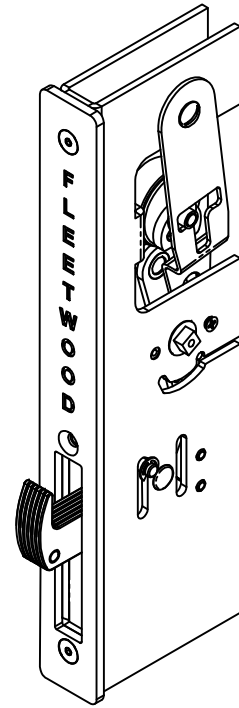

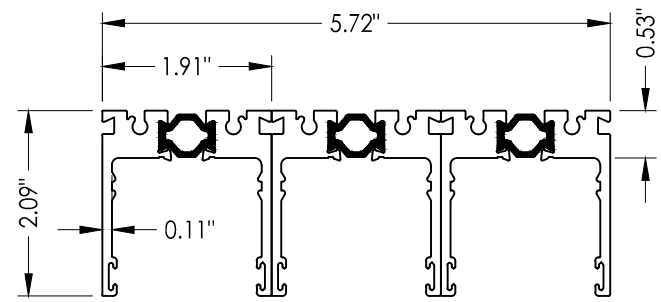

 Report #: E8390-301-18
 Date: 07/13/16
 Verified by: *[Signature]*

MATERIAL: SERIES 3070-T		DRAWN BY: BL	DATE: 6/22/15	REVISIONS: REV-1	DATE: 6/28/16	DRAWN BY: BL	COMMENTS: UPDATED GLASS
CUSTOMER: FLEETWOOD WINDOWS AND DOORS		JOB NUMBER: 385199-V2					
JOB NAME: FLEETWOOD TAS & AAMA TEST							
 FLEETWOOD WINDOWS AND DOORS <small>1 FLEETWOOD WAY CORONA, CALIFORNIA 92709 - www.fleetwoodusa.com</small>							
SCALE: DO NOT SCALE							
DRAWING NO.: 10							
SHEET: 10 OF 12							

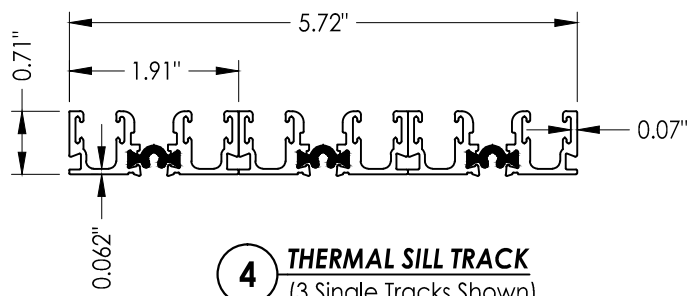

1 THERMAL HEAD TRACK
(3 Single Tracks Shown)



4 THERMAL SILL TRACK
(3 Single Tracks Shown)

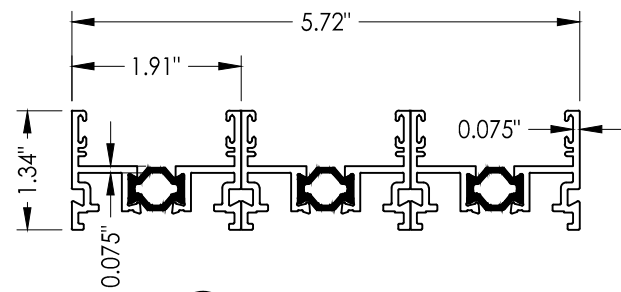

7 THERMAL JAMB
(3 Single Tracks Shown)

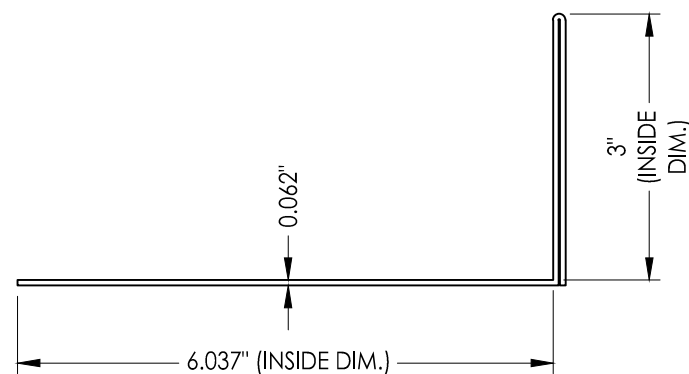

14 SILLPAN - 3 TRACK

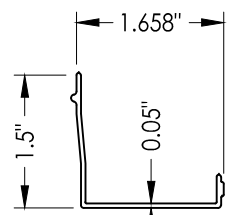

9 HEAD FILLER

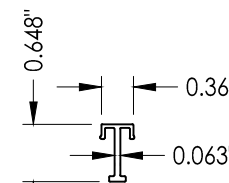

10 SILL FILLER

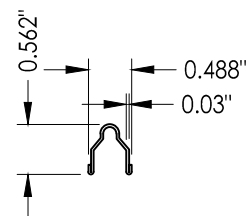

13 TRACK

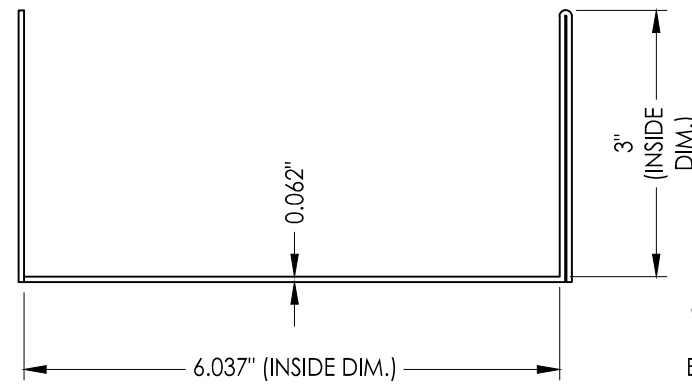

15 SILLPAN - 3 TRACK
(Pocket)

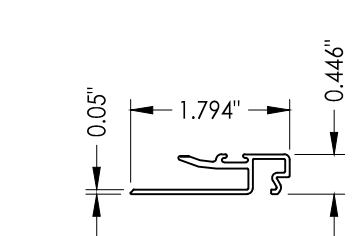

12 J-TYPE POST INTERLOCK

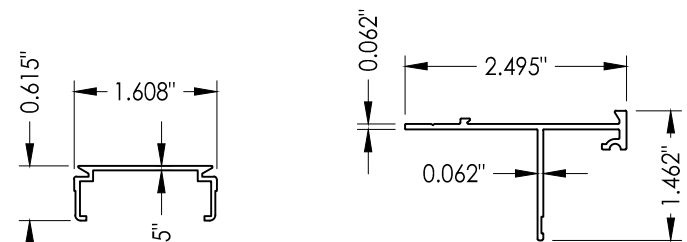

11 JAMB FILLER

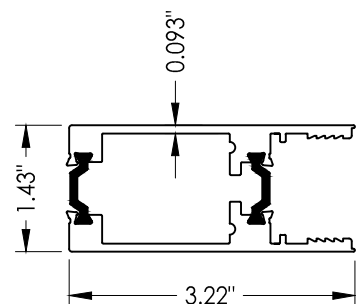

23 THERMA LOCK STILE
ARCHETYPE NARROW

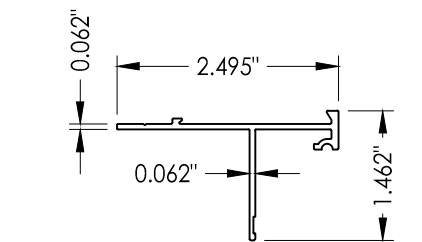

47 POST INTERLOCKER NAIL-FIN

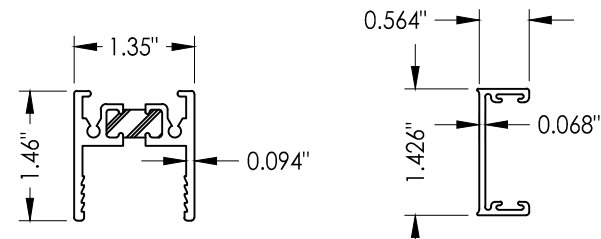

20 THERMAL TOP RAIL

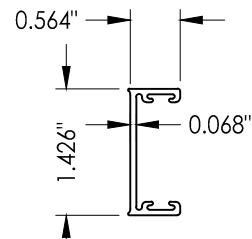

27 FEMALE YOKE

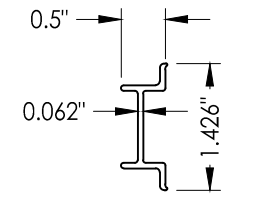

28 MALE YOKE

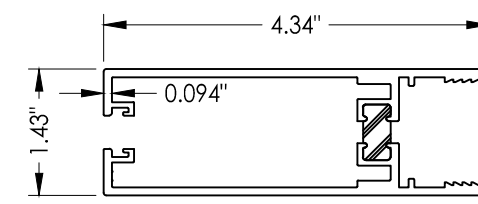

24 THERMAL LOCK STILE

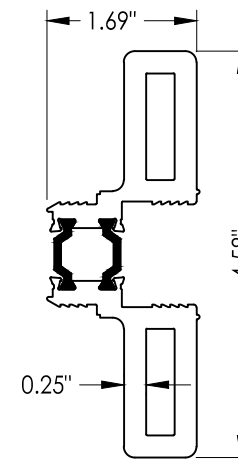

30 THERMAL HP ADAPTOR

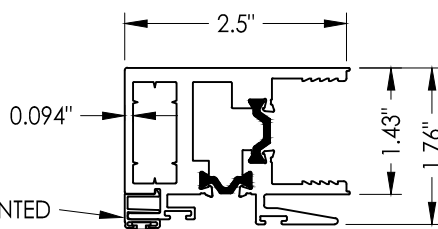

25 THERMAL HP FIXED INTERLOCKER

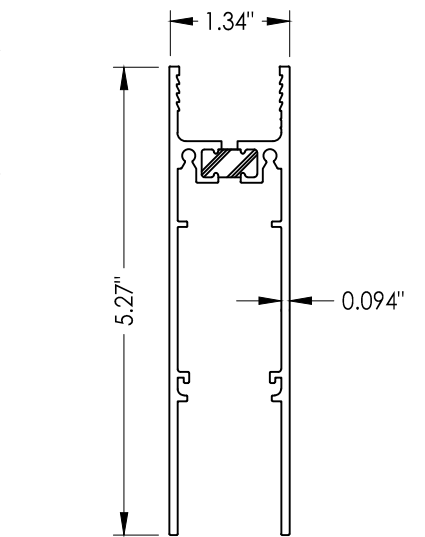

21 THERMAL BOTTOM RAIL

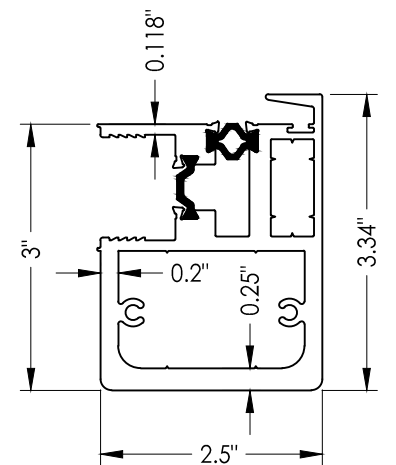

26 THERMAL HP INTERLOCKER

6" AIR BARRIER MOUNTED
@ TOP & BOTTOM OF
EXTERIOR INTERLOCK STILE

MATERIAL: SERIES 3070-T		DATE: 6/22/15	REVISIONS: REV-1	DATE: 6/28/16	DRAWN BY: BL	COMMENTS: UPDATED GLASS
CUSTOMER: FLEETWOOD WINDOWS AND DOORS		DATE: 6/22/15	REVISIONS: REV-1	DATE: 6/28/16	DRAWN BY: BL	COMMENTS: UPDATED GLASS
JOB NAME: FLEETWOOD TAS & AAMA TEST		DATE: 6/22/15	REVISIONS: REV-1	DATE: 6/28/16	DRAWN BY: BL	COMMENTS: UPDATED GLASS
JOB NUMBER: 385199-V2		DATE: 6/22/15	REVISIONS: REV-1	DATE: 6/28/16	DRAWN BY: BL	COMMENTS: UPDATED GLASS

FLEETWOOD
WINDOWS AND DOORS
1 FLEETWOOD WAY CORONA, CALIFORNIA 92709 - www.fleetwoodusa.com

SCALE: DO NOT SCALE
DRAWING NO.: 11
SHEET: 11 OF 12

Intertek Report #: E8390-301-18
Date: 07/13/16
Verified by: *[Signature]*

BILL OF MATERIALS			
ITEM #	DESCRIPTION	PART#	MATERIAL
B	2X BUCK SG >= 0.55	N/A	WOOD
C	1/4" MAX. SHIM SPACE	N/A	-
D	#10 x 2-1/2" PFH WOOD SCREW	N/A	STEEL
F	#10 x 2" PPH WOOD SCREW	N/A	STEEL
G	#8 x 1-1/2" PFH WOOD SCREW	N/A	STEEL
H	#8 x 3/4" PPH SMS	N/A	STEEL
1	THERMAL HEAD (SINGLE TRACK)	3700	6063-T6 ALUM
4	THERMAL SILL (SINGLE TRACK)	3749	6063-T6 ALUM
7	THERMAL JAMB (SINGLE TRACK)	3711	6063-T6 ALUM
9	HEAD FILLER	3014	STAINLESS STEEL
10	SILL FILLER	3747	STAINLESS STEEL
11	JAMB FILLER	3710	STAINLESS STEEL
12	J-POST INTERLOCKER SNAP-IN	3755	STAINLESS STEEL
13	S.S. TRACK	FW1020	-
14	SILL PAN (3-TRACK)	3720-3	-
15	SILL PAN (3-TRACK)(POCKET)	3720-3	-
16	SMALL FIN SEAL .230	19118	6063-T6 ALUM
17	9/16" GLAZING VINYL (ASTM C864)	25033	6063-T6 ALUM
18	LARGE FIN SEAL .290	19117	6063-T6 ALUM
19	Q-LON (U5212)	19120	6063-T6 ALUM
20	THERMAL TOP RAIL	3004	6063-T6 ALUM
21	THERMAL BOTTOM RAIL	3027	6063-T6 ALUM
23	LOCK STILE (ARCHETYPE NARROW)	3773	6061-T6 ALUM
24	THERMAL LOCK STILE	3771	6061-T6 ALUM
25	HP THERMAL FIXED INTERLOCKER	3728	6061-T6 ALUM
26	HP THERMAL INTERLOCKER	3031	6061-T6 ALUM
27	FEMALE YOKE	3040	6061-T6 ALUM
28	MALE YOKE	3039	6061-T6 ALUM
29	WINDLOAD ADAPTOR	3715	6061-T6 ALUM
30	THERMAL HP ADAPTOR	3716	STAINLESS STEEL
31	0.31" X 1" SOLID ALUMINUM	N/A	6061-T6 ALUM
32	1.25" X 1.5" SOLID ALUMINUM	N/A	6061-T6 ALUM
33	135° SOLID YOKE BLOCK (ALUMINUM)	N/A	6061-T6 ALUM
37	0.75" X 1.25" SOLID ALUMINUM	N/A	6061-T6 ALUM
38	AIR BARRIER (SILL)	25383	-
39	AIR BARRIER (HEAD)	24097	-
40	6" AIR BARRIER FOR HP INTERLOCKER	25562	-
41	STRIKE PLATE	24980	STEEL
42	BACK UP PLATE	24981	STEEL
43	10-32 X .5" FHP	N/A	STEEL
44	#10 X 1" PHP	N/A	STEEL
45	#8 TEK X 1/2"	N/A	STEEL
46	DOW 995 SILICONE	N/A	-
47	POST INTERLOCKER NAIL-FIN	3756	6061-T6 ALUM
48	FLUSH PULL	-	S.S.
49	ARCHETYPE NARROW LOCK	-	-
50	ARCHETYPE LOCK	-	-
51	ARCHETYPE ROLLERS	-	-

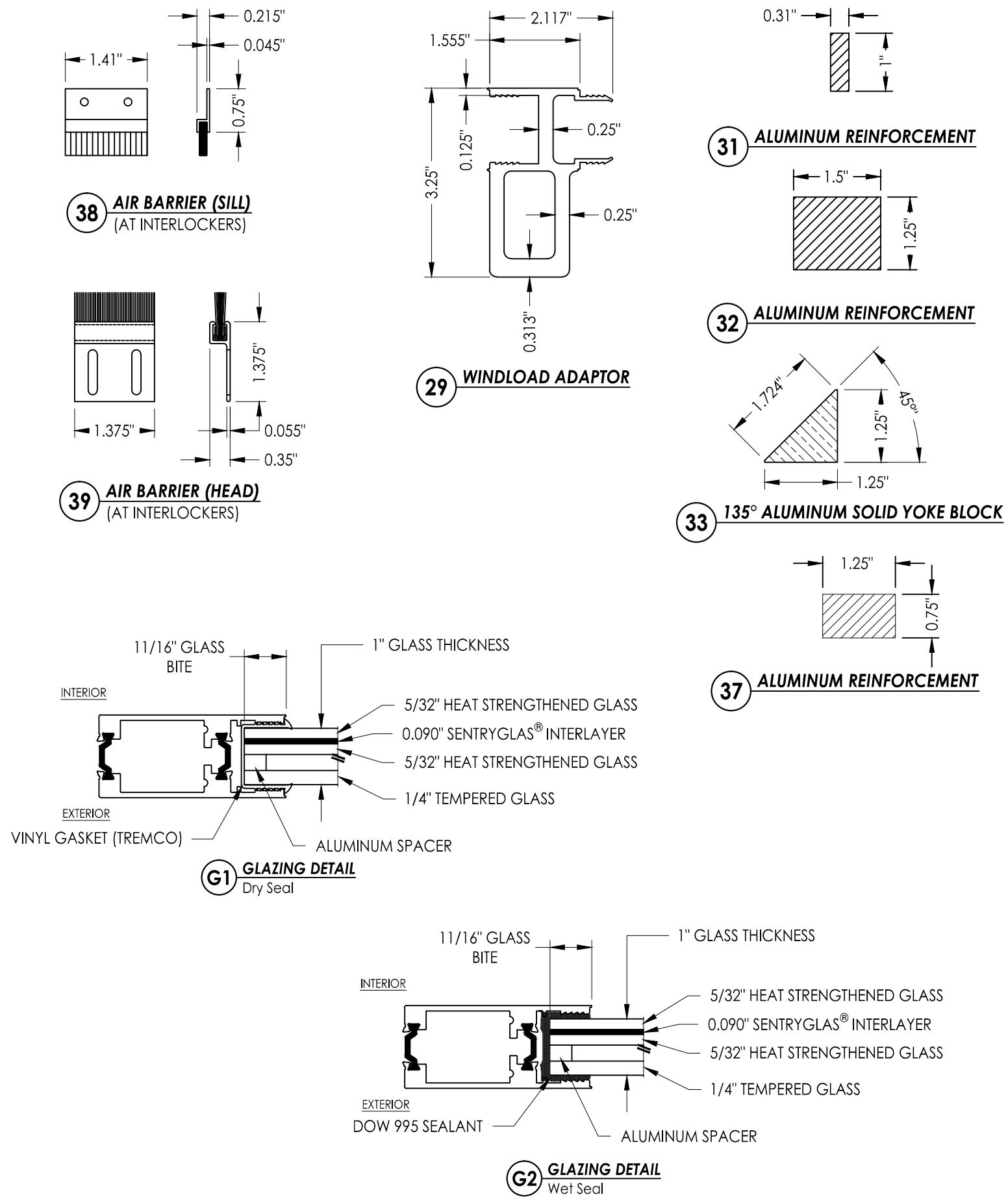

 Report #: E8390-301-18
 Date: 07/13/16
 Verified by: *[Signature]*

COMMENTS	UPDATED GLASS
DRAWN BY	BL
DATE	6/28/16
REVISIONS	REV-1
DATE	6/22/15
DRAWN BY	BL
JOB NUMBER	385199-V2
MATERIAL	SERIES 3070-T
CUSTOMER	FLEETWOOD WINDOWS AND DOORS
JOB NAME	FLEETWOOD TAS & ANIA TEST

FLEETWOOD
WINDOWS AND DOORS
1 FLEETWOOD WAY CORONA, CALIFORNIA 92709 - www.fleetwoodusa.com



SCALE: **DO NOT SCALE**
 DRAWING NO.: **12**
 SHEET: **12 OF 12**