



ASTM E1886 and ASTM E1996 TEST REPORT

Report No.: E8391.02-301-44

Rendered to:

FLEETWOOD WINDOWS AND DOORS
Corona, California

PRODUCT TYPE: Sliding Door
SERIES/MODEL: 3070-HI

Test Dates: 07/01/15
Through: 08/19/15
Report Date: 12/04/15
Revision 3 Date: 04/01/16
Record Retention End Date: 08/19/19



1.0 Report Issued To: Fleetwood Windows & Doors
1 Fleetwood Way
Corona, California 92879

2.0 Test Laboratory: Architectural Testing, Inc.
2524 East Jensen Avenue
Fresno, California 93706
(559) 233-8705

3.0 Project Summary:

3.1 Product Type: Sliding Door

3.2 Series/Model: 3070-HI

3.3 Compliance Statement: Results obtained are tested values and were secured by using the designated test method(s). The specimen(s) tested met the performance requirements set forth in the referenced test procedures for a +2640/-2880 Pa (+55.14/-60.15psf) Design Pressure with missile impacts corresponding to Missile Level D and Wind Zone 4.

3.4 Test Dates: 07/01/15 - 08/19/15

3.5 Test Record Retention End Date: All test records for this report will be retained until August 19, 2019.

3.6 Test Location: Architectural Testing, Inc. test facility in Fresno, California.

3.7 Test Specimen Source: The test specimen(s) was provided by the client. Representative samples of the test specimen(s) will be retained by Architectural Testing for a minimum of four years from the test completion date.

3.8 Drawing Reference: The test specimen drawings have been reviewed by Architectural Testing and are representative of the test specimen(s) reported herein. Test specimen construction was verified by Architectural Testing per the drawings located in Appendix B. Any deviations are documented herein or on the drawings.

3.0 Project Summary: (Continued)

3.9 List of Official Observers:

<u>Name</u>	<u>Company</u>
Nathan Baker	Fleetwood
Dennis Janzen	Intertek-ATI
Tyler Westerling	Intertek-ATI

4.0 Test Specification(s):

ASTM E1886-13a, *Standard Test Method for Performance of Exterior Windows, Curtain Walls, Doors, and Impact Protective Systems Impacted by Missile(s) and Exposed to Cyclic Pressure Differentials*

ASTM E1996-14a, *Standard Specification for Performance of Exterior Windows, Curtain Walls, Doors, and Impact Protective Systems Impacted by Windborne Debris in Hurricanes*

5.0 Test Specimen Description:

5.1 Product Sizes:

Overall Area: 22.8 m ² (243 ft ²)	Width		Height	
	millimeters	inches	millimeters	inches
MAX Overall size	6,096	240	3,658	144
MAX Panel size	1,588	62-1/16	3,607	142

5.0 Test Specimen Description: (Continued)

The following descriptions apply to all specimens.

5.2 Frame Construction:

Frame Member	Material	Description
Sill	Aluminum	Two piece sill held in place with two rows of #8 Phillips head screws spaced 36" on center in each track.
Sill pan	Aluminum	With a 1.93" tall interior leg.
Sill filler	Aluminum	Snapped in place where panels do not slide.
Jamb	Aluminum	With snapped in jamb filler where panel is not engaged.
Head	Aluminum	With snapped in head filler where panel is not engaged.

	Joinery Type	Detail
All corners	Butt	Sealed with silicone and attached with three #10 x 3/4" Phillips pan head sheet metal screws.

5.3 Panel Construction:

Panel Member	Material	Description
All	Aluminum	See drawings for details.

	Joinery Type	Detail
All corners	Butt	Sealed with silicone. Top corners fastened with one #10 x 2" Phillips head screw each. Bottom corners fastened with one #10 x 2". Two 1/4-20 x 1" Phillips head screws were fastened into each roller.

5.0 Test Specimen Description: (Continued)

5.4 Weatherstripping:

Description	Quantity	Location
0.230 polypile with center fin	4	In sill contracting interior and exterior of each panel leg.
Q-lon foam seal	2	Contacting interior and exterior of subsill pan from sill vertical face.
0.230 polypile with center fin	2	In head contracting interior and exterior of panel face.
0.290 Polypile with center fin	1	In each pocket interlock extrusion.
0.230 polypile with center fin	2	In interior and exterior meeting stile locking extrusion.
0.290 polypile with center fin	1	In each interlock extrusion.
Q-lon foam seal	1	In interior and exterior of jamb extrusion.
Panel corner air barrier	1	At each exposed panel bottom and top corner.

5.5 Glazing: *No conclusions of any kind regarding the adequacy or inadequacy of the glass in any glazed test specimen(s) can be made.*

Glass Type	Glazing	Glazing Method
Monolithic	6mm clear/0.090 SGP/6mm clear	Channel glazed into frame. Dry glazed at all top and bottom rails and interlocks. (Wet glazed at locking vertical stiles only. > 30DP Specimens #4 and #6)

Location	Quantity	Daylight Opening		Glass Bite
		millimeters	inches	
All Lights	4	1435 x 3454	56-1/2 x 136	5/8

5.6 Drainage:

Drainage Method	Size	Quantity	Location
Saw cut across sill across all tracks	1" wide by 3/16" deep	6	6" from each end, 60" spacing.
Bottom drain or side drain	1" NPT	6	8" from each and 60" on center drained into a common 2" diameter manifold with check valve.

5.0 Test Specimen Description: (Continued)

5.7 Hardware:

Description	Quantity	Location
Rollers, Tandem	2 tandem rollers each panel	Bottom panel rail
Archetype Narrow lock with strike plate	1	Locking meeting panel

5.8 Reinforcement:

Drawing Number	Location	Material
37	All small interlock hallows	Aluminum
38	All small interlock hallows	Aluminum

5.9 Screen Construction: No screen was utilized.

6.0 Installation:

The specimen was installed into a Pine wood buck. The rough opening allowed for a 1/4" shim space. The exterior perimeter of the window was sealed with sealant. See drawing on sheet 6 of 9 for installation details.

7.0 Test Results: The results are tabulated as follows:

ASTM E1886, Large

Conditioning Temperature: 18°C (65°F)

Missile Weight: 4080 g (9.0 lbs.)

Missile Length: 2.4 m (8'0")

Muzzle Distance from Test Specimen: 5.2 m (17' 0")

Test Unit #1: Orientation within $\pm 5^\circ$ of horizontal

Impact #1: Missile Velocity: 15.1 m/s (49.6fps)	
Impact Area:	Center of meeting stile
Observations:	Missile hit target area
Results:	Pass

Impact #2: Missile Velocity: 15.2 m/s (50.0 fps)	
Impact Area:	Center of Pocket Panel
Observations:	Missile hit target area
Results:	Pass

Impact #3: Missile Velocity: 15.1 m/s (49.6fps)	
Impact Area:	Bottom right hand corner of pocket panel
Observations:	Missile hit target area
Results:	Pass

Impact #4: Missile Velocity: 15.2 m/s (49.7 fps)	
Impact Area:	Center of Meeting panel
Observations:	Missile hit target area
Results:	Pass

7.0 Test Results: (Continued)

ASTM E1886, Large

Conditioning Temperature: 18°C (65°F)

Missile Weight: 4080 g (9.0 lbs.)

Missile Length: 2.4 m (8'0")

Muzzle Distance from Test Specimen: 5.2 m (17' 0")

Test Unit #2: Orientation within $\pm 5^\circ$ of horizontal

Impact #1: Missile Velocity: 15.0 m/s (49.3fps)	
Impact Area:	Center of meeting stile
Observations:	Missile hit target area
Results:	Pass

Impact #2: Missile Velocity: 15.1 m/s (49.6 fps)	
Impact Area:	Bottom left of Pocket Panel
Observations:	Missile hit target area
Results:	Pass

Impact #3: Missile Velocity: 15.3 m/s (50.1fps)	
Impact Area:	Center of pocket panel
Observations:	Missile hit target area
Results:	Pass

Impact #4: Missile Velocity: 15.3 m/s (50.2 fps)	
Impact Area:	Top right corner of meeting panel
Observations:	Missile hit target area
Results:	Pass

Impact #5: Missile Velocity: 15.2 m/s (49.8fps)	
Impact Area:	Center of meeting panel
Observations:	Missile hit target area
Results:	Pass

7.0 Test Results: (Continued)

ASTM E1886, Large

Conditioning Temperature: 18°C (65°F)
Missile Weight: 4080 g (9.0 lbs.)
Missile Length: 2.4 m (8'0")
Muzzle Distance from Test Specimen: 5.2 m (17' 0")

Test Unit #3: Orientation within ±5° of horizontal

Impact #1: Missile Velocity: 15.2 m/s (49.9fps)	
Impact Area:	Center of interlock
Observations:	Missile hit target area
Results:	Pass
Deflection:	

Impact #2: Missile Velocity: 15.3 m/s (50.2 fps)	
Impact Area:	Top left corner of jamb panel
Observations:	Missile hit target area
Results:	Pass

Impact #3: Missile Velocity: 15.4 m/s (50.4 fps)	
Impact Area:	Center of jamb panel
Observations:	Missile hit target area
Results:	Pass

Impact #4: Missile Velocity: 15.1 m/s (49.5 fps)	
Impact Area:	Center of Meeting panel
Observations:	Missile hit target area
Results:	Pass

Impact #5: Missile Velocity: 15.2 m/s (49.7fps)	
Impact Area:	bottom right corner of meeting panel
Observations:	Missile hit target area
Results:	Pass

Note: See Intertek-ATI Sketch #1 for impact locations.

7.0 Test Results: (Continued)

ASTM E1886, Air Pressure Cycling

Test Unit #1

Design Pressure: a +2640/-2880 Pa (+55.14/-60.15psf)

POSITIVE PRESSURE

Pressure Range (psf)	Number of Cycles	Average Cycle Time (seconds)	Observations
11 to 27.5	3500	2.8	
0 to 33	300	4.2	
27.5 to 44	600	2.3	
16.5 to 55	100	4.0	

NEGATIVE PRESSURE

Pressure Range (psf)	Number of Cycles	Average Cycle Time (seconds)	Observations
18 to 60	50	4.7	
30 to 48	1050	2.1	
0 to 36	50	4.2	
12 to 30	3350	2.3	

Result: Pass

7.0 Test Results: (Continued)

ASTM E1886, Air Pressure Cycling

Test Unit #2

Design Pressure: a +2640/-2880 Pa (+55.14/-60.15psf)

POSITIVE PRESSURE

Pressure Range (psf)	Number of Cycles	Average Cycle Time (seconds)	Observations
11 to 27.5	3500	2.3	
0 to 33	300	4.2	
27.5 to 44	600	2.1	
16.5 to 55	100	4.1	

NEGATIVE PRESSURE

Pressure Range (psf)	Number of Cycles	Average Cycle Time (seconds)	Observations
18 to 60	50	4.4	
30 to 48	1050	2.3	
0 to 36	50	4.5	
12 to 30	3350	2.0	

Result: Pass

7.0 Test Results: (Continued)

ASTM E1886, Air Pressure Cycling

Test Unit #3

Design Pressure: a +2640/-2880 Pa (+55.14/-60.15psf)

POSITIVE PRESSURE

Pressure Range (psf)	Number of Cycles	Average Cycle Time (seconds)	Observations
11 to 27.5	3500	2.1	
0 to 33	300	4.4	
27.5 to 44	600	2.3	
16.5 to 55	100	4.5	

NEGATIVE PRESSURE

Pressure Range (psf)	Number of Cycles	Average Cycle Time (seconds)	Observations
18 to 60	50	4.4	
30 to 48	1050	2.3	
0 to 36	50	4.6	
12 to 30	3350	2.5	

Result: Pass

General Note: Upon completion of testing, the specimens met the requirements of Section 7 of ASTM E1996.

8.0 Test Equipment:

Cannon: Constructed from steel piping utilizing compressed air to propel the missile

Missile: 2x4 Southern Pine

Timing Device: Electronic Beam Type

Cycling Mechanism: Computer controlled centrifugal blower with electronic pressure measuring device

Tape and film were not used to seal against air leakage during structural testing.

Intertek-ATI will service this report for the entire test record retention period. Test records such as detailed drawings, datasheets, representative samples of test specimens, or other pertinent project documentation, will be retained by Intertek-ATI for the entire test record retention period.

This report does not constitute certification of this product nor an opinion or endorsement by this laboratory. It is the exclusive property of the client so named herein and relates only to the specimen(s) tested. This report may not be reproduced, except in full, without the written approval of Intertek-ATI.

For ARCHITECTURAL TESTING, INC.:

Dennis Janzen
Technician

Tyler Westerling, P.E.
Senior Project Engineer

TW:ss

Attachments (pages): This report is complete only when all attachments listed are included.

Appendix A: Sketches (2)

Appendix B: Drawings: (9)

Revision Log

Rev. #	Date	Page(s)	Revision(s)
0	12/04/15	N/A	Original report issue.
1	02/09/16	Appendix B	Revised drawings.
2	02/12/16	4	Corrected air barrier description
3	04/01/16	3	Corrected panel corner description
3	04/01/16	4	Corrected panel corner detail.
3	04/01/16	5	Corrected hardware spelling.
3	04/01/16	6	Corrected installation details.
3	04/01/16	Appendix B	Updated drawing package.

This report produced from controlled document template ATI 00498, revised 06/19/15.

Appendix A

Sketches

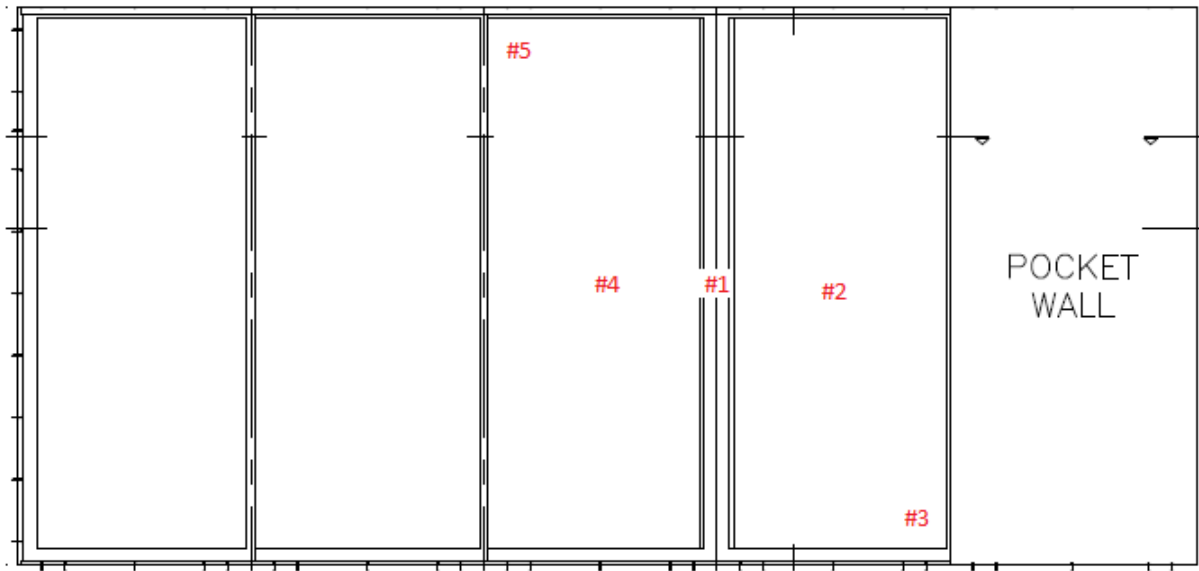

Sketch #1: Specimen #1 Impact Locations

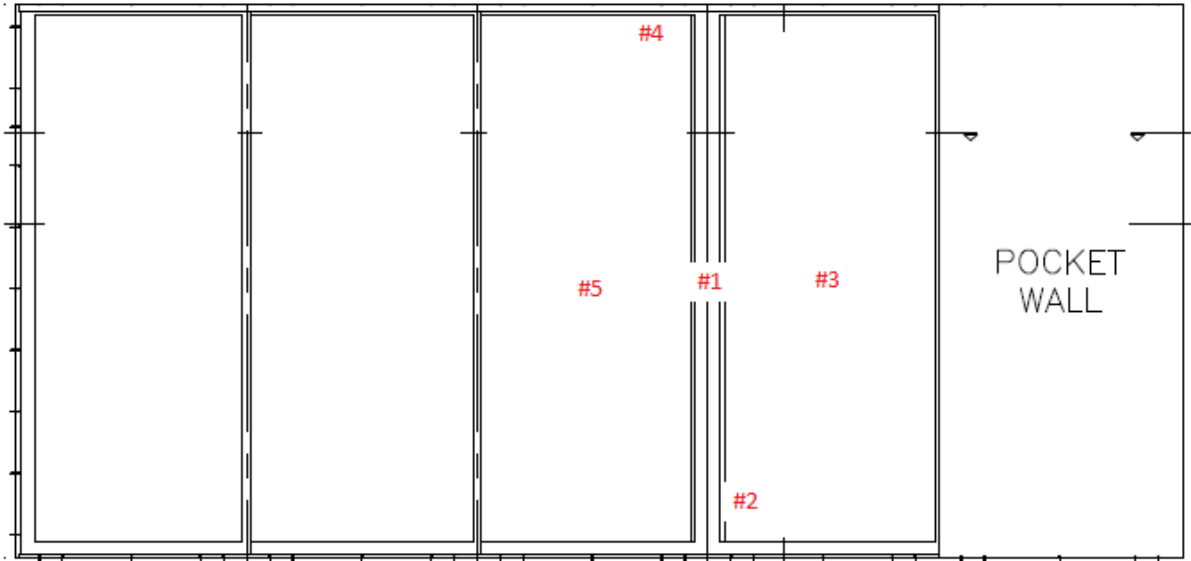

Sketch #2: Specimen #2 Impact Locations

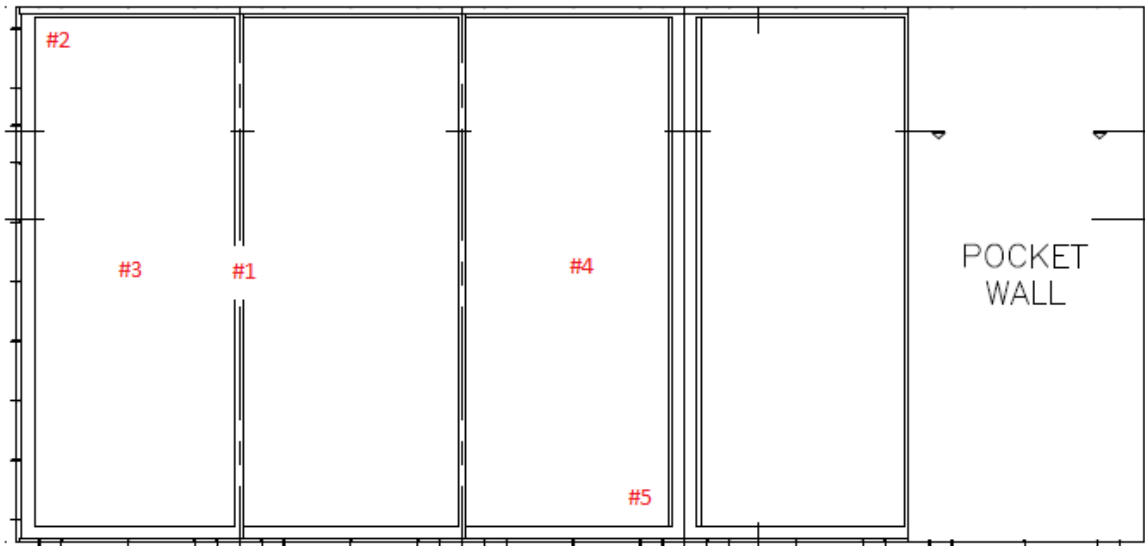

Sketch #3: Specimen #3 Impact Locations

Appendix B

Drawings

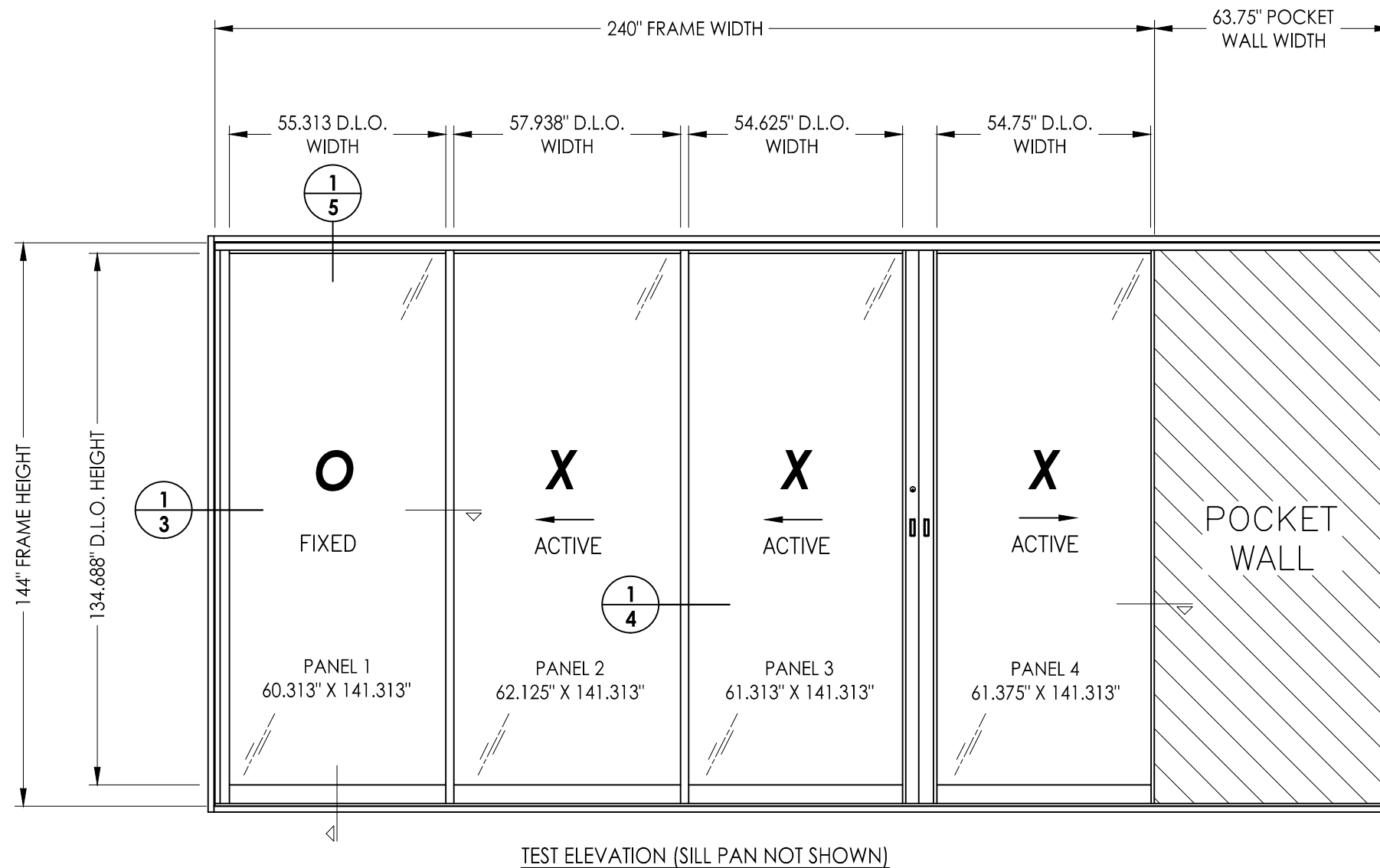

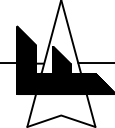
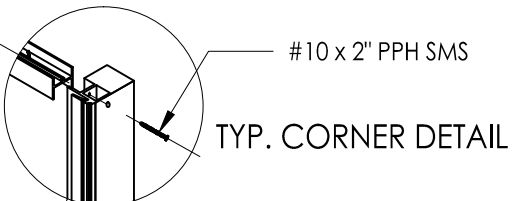
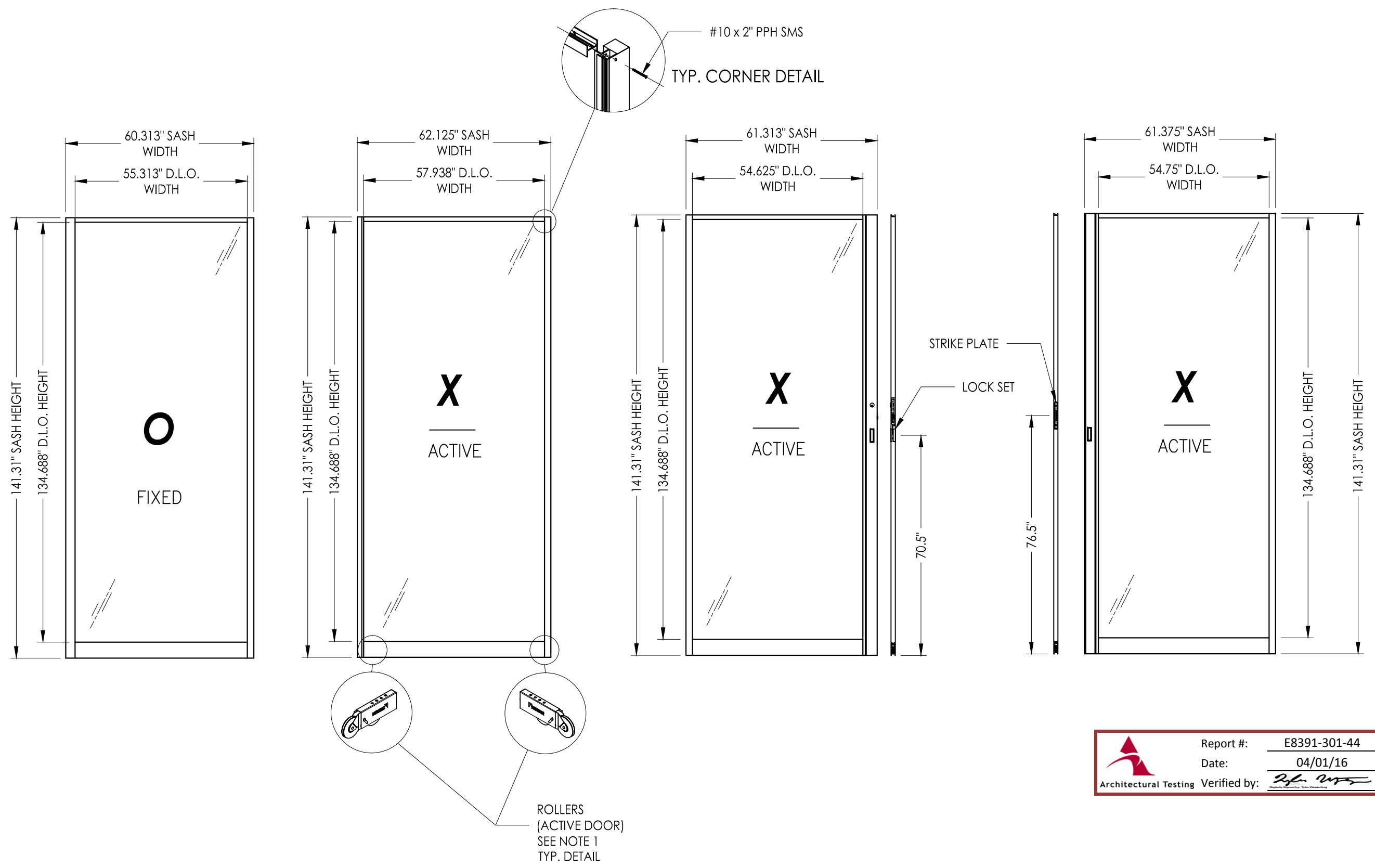

TABLE OF CONTENTS

SHEET #	DESCRIPTION
1	Table of contents and test elevation
2	Sash details
3	Horizontal cross section
4	Horizontal cross section
5	Vertical cross sections
6	Frame anchoring
7	Hardware Components
8	Hardware Components
9	Components
10	Bill of materials, components and glazing details

 Report #: E8391-301-44
 Date: 04/01/16
 Verified by: *[Signature]*

COMMENTS	
DRAWN BY	
DATE	
REVISIONS	
DATE:	6/22/15
DRAWN BY:	BL
JOB NUMBER:	385199-V2
MATERIAL:	SERIES 3070-HI
CUSTOMER:	FLEETWOOD WINDOWS AND DOORS
JOB NAME:	FLEETWOOD TAS & AAMA TEST
	
	
SCALE: DO NOT SCALE	
DRAWING NO.: #####	
SHEET: 1 OF 9	



ROLLERS
(ACTIVE DOOR)
SEE NOTE 1
TYP. DETAIL

	Report #:	E8391-301-44
	Date:	04/01/16
	Verified by:	<i>[Signature]</i>

Note:
1. Roller attached to bottom rail utilizing (2) 1/4-20 x 1/2\"/>

COMMENTS					
DRAWN BY					
DATE					
REVISIONS					
DATE:	6/22/15	JOB NUMBER:	385199-V2		
DRAWN BY:	BL				
MATERIAL:	SERIES 3070-HI				
CUSTOMER:	FLEETWOOD WINDOWS AND DOORS				
JOB NAME:	FLEETWOOD TAS & AAMA TEST				
FLEETWOOD WINDOWS AND DOORS <small>1 FLEETWOOD WAY CORONA, CALIFORNIA 92709 - www.fleetwoodusa.com</small>					
SCALE: DO NOT SCALE					
DRAWING NO.: #####					
SHEET: 2 OF 9					

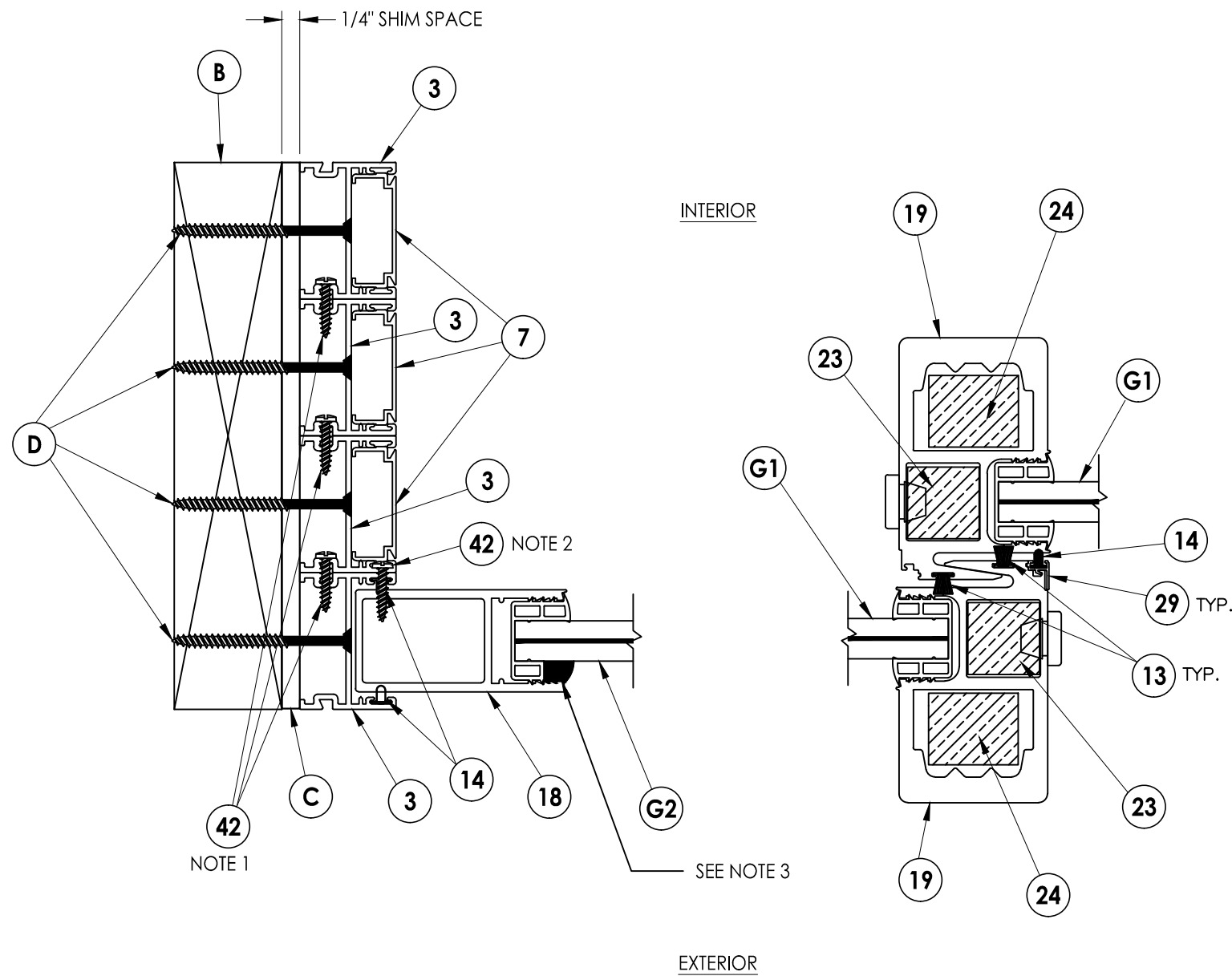

1
3 HORIZONTAL CROSS SECTION

- NOTE:
1. 1" from each end then 60" on center.
 2. 48" from each end (2) total
 3. Interior or exterior (gasket cut 2" from top rail and bottom rail on stile).

 Architectural Testing	Report #:	E8391-301-44
	Date:	04/01/16
	Verified by:	<i>[Signature]</i>

MATERIAL:	SERIES 3070-HI	DRAWN BY:	BL	DATE:	6/22/15	REVISIONS:		COMMENTS:	
CUSTOMER:	FLEETWOOD WINDOWS AND DOORS	JOB NUMBER:	385199-V2						
JOB NAME:	FLEETWOOD TAS & AAMA TEST								
FLEETWOOD WINDOWS AND DOORS <small>1 FLEETWOOD WAY CORONA, CALIFORNIA 92709 - WWW.FLEETWOODUSA.COM</small>									
									
SCALE ↓ DO NOT SCALE									
DRAWING NO. ↓ #####									
SHEET ↓ 3 OF 9									

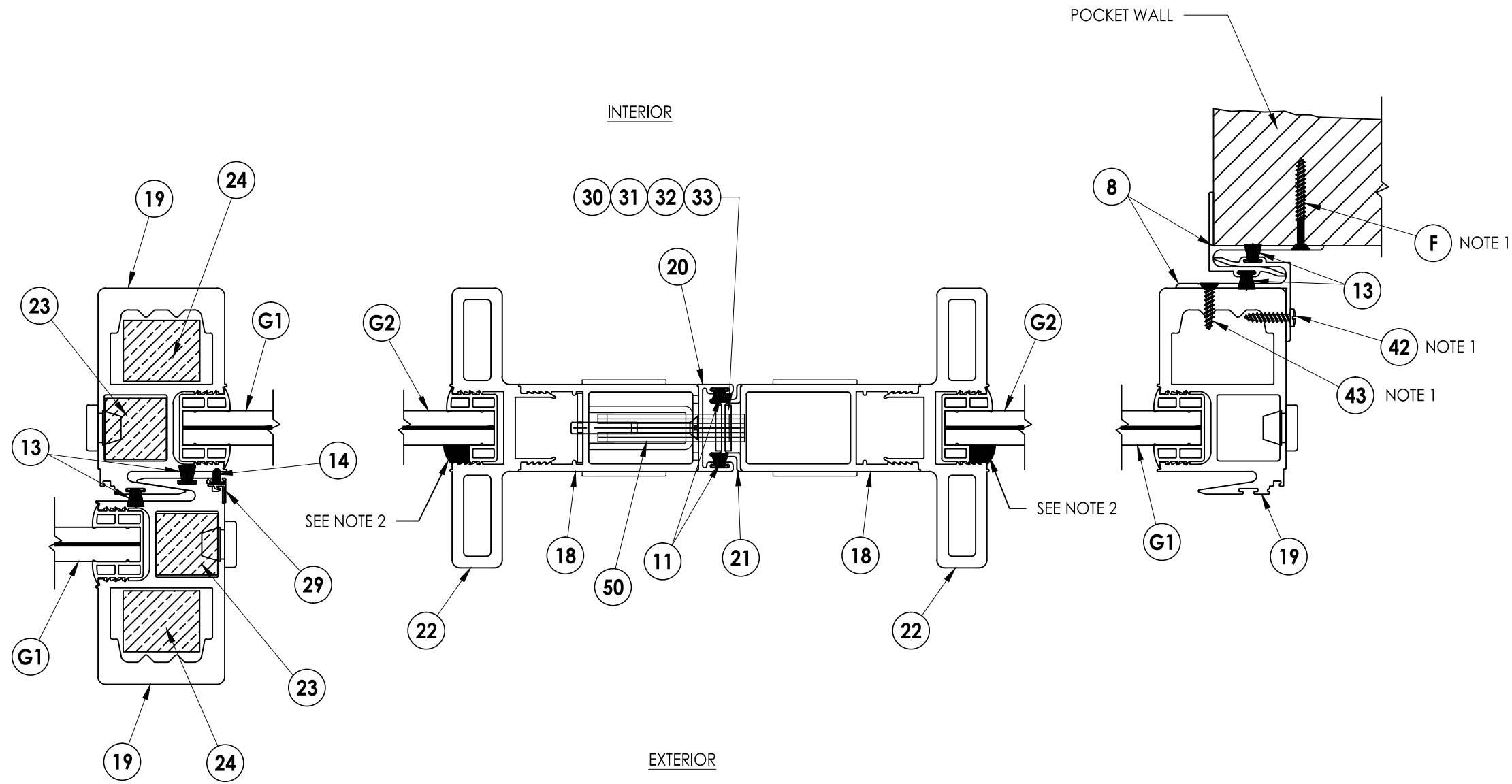

1
4 HORIZONTAL CROSS SECTION

	Report #:	E8391-301-44
	Date:	04/01/16
	Verified by:	<i>[Signature]</i>

NOTE:
 1. 2" from each end then 12" on center
 2. Interior or exterior (gasket cut 2" from top rail and bottom rail on stile).

REVISIONS	DATE	DRAWN BY	COMMENTS

MATERIAL:	SERIES 3070-HI
CUSTOMER:	FLEETWOOD WINDOWS AND DOORS
JOB NAME:	FLEETWOOD TAS & AAMA TEST

DATE:	6/22/15	JOB NUMBER:	385199-V2
DRAWN BY:	BL		

SCALE	↓
DO NOT SCALE	
DRAWING NO.	####
SHEET	4 OF 9

 Report #: E8391-301-44
 Date: 04/01/16
 Verified by: *[Signature]*

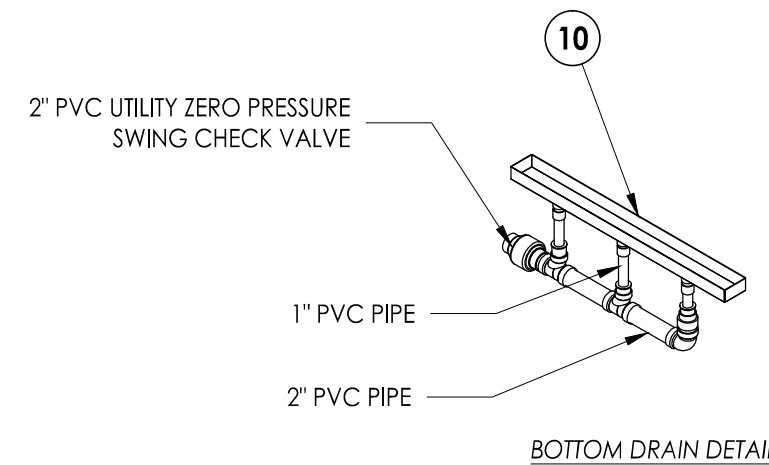
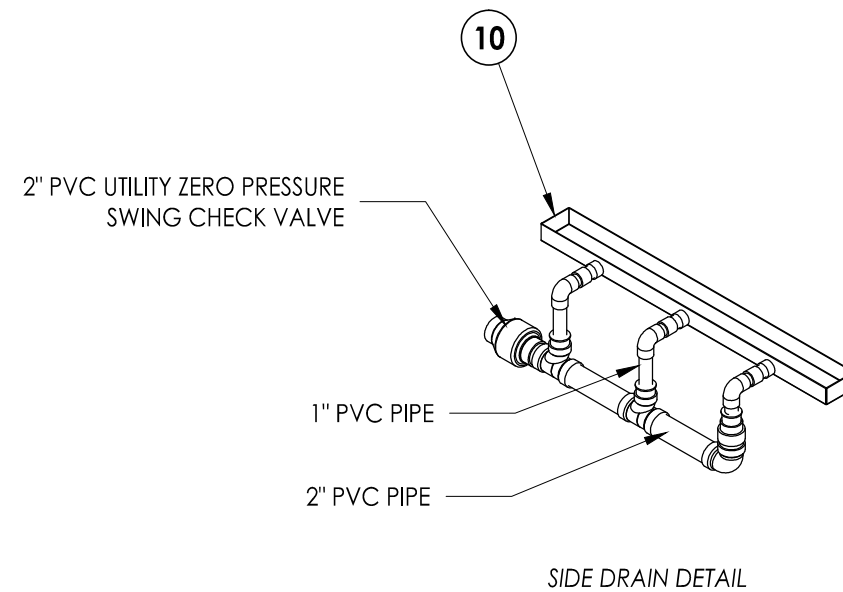
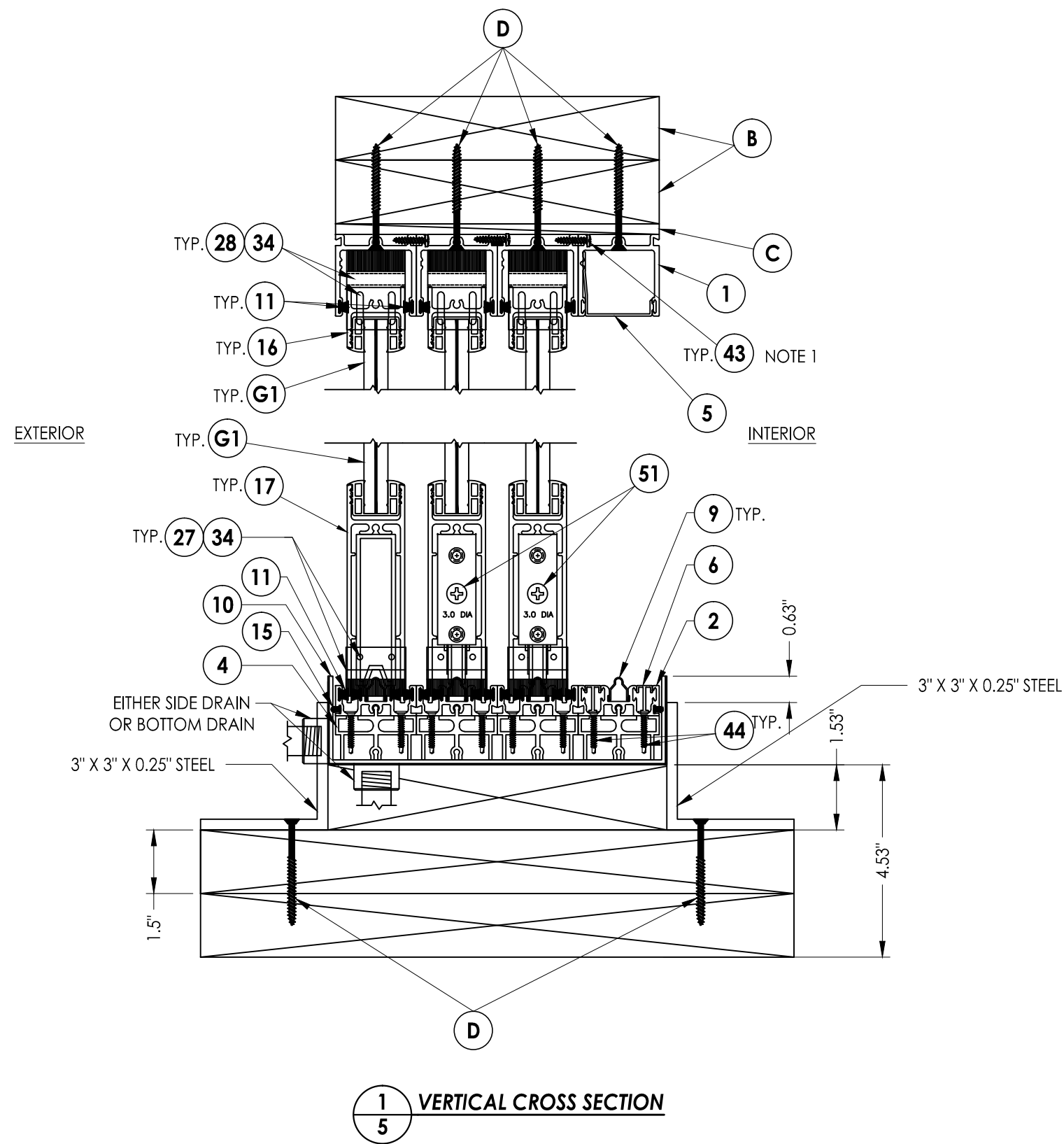

NOTE:
 1. 1" from each end then 60" on center.

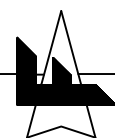
COMMENTS					
DRAWN BY					
DATE					
REVISIONS					
DATE:	6/22/15				
DRAWN BY:	BL				
JOB NUMBER:	385199-V2				
MATERIAL:	SERIES 3070-HI				
CUSTOMER:	FLEETWOOD WINDOWS AND DOORS				
JOB NAME:	FLEETWOOD TAS & AAMA TEST				
FLEETWOOD WINDOWS AND DOORS <small>1 FLEETWOOD WAY CORONA, CALIFORNIA 92779 - www.fleetwoodusa.com</small>					
					
SCALE ↓ DO NOT SCALE					
DRAWING NO. ↓ #####					
SHEET ↓ 5 OF 9					

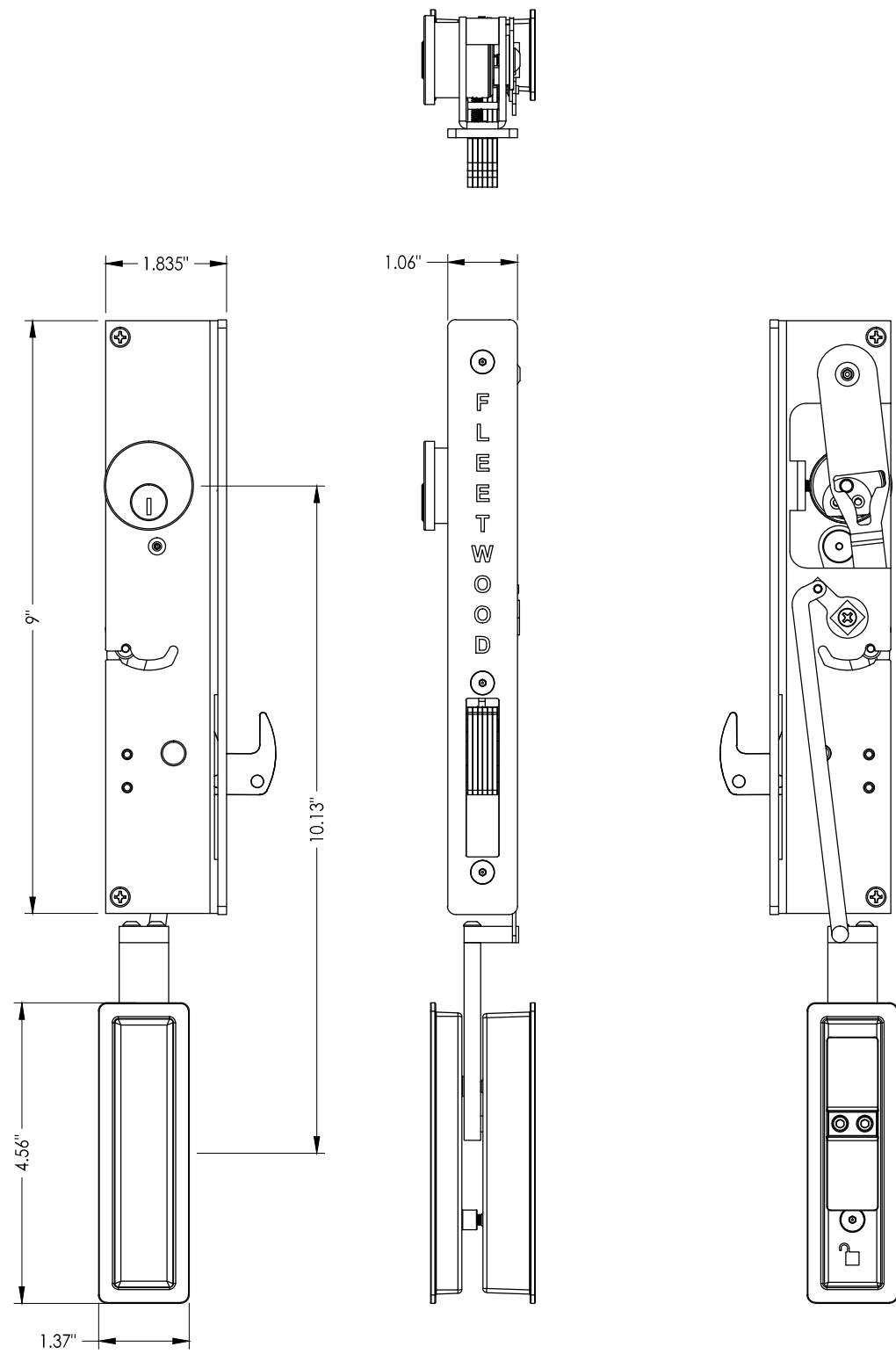

49 ARCHETYPE NARROW LOCK

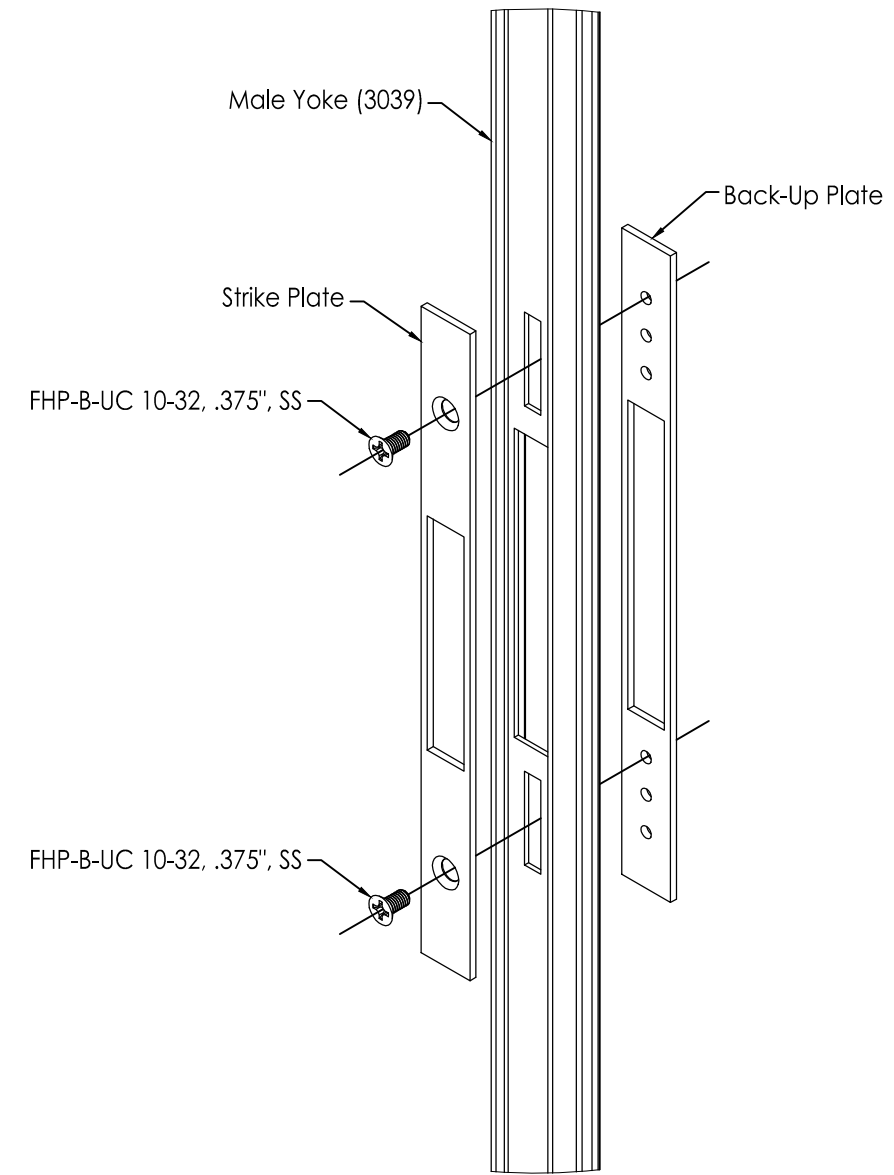
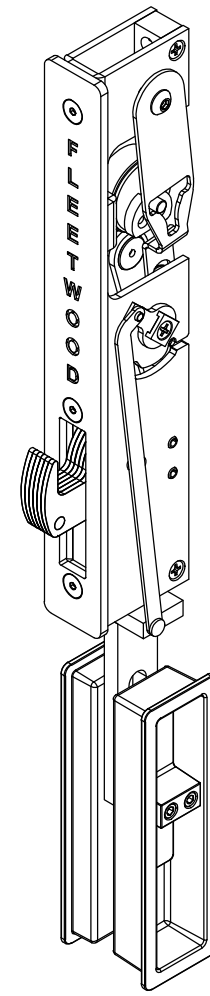

30 STRIKE PLATE

	Report #:	E8391-301-44
	Date:	04/01/16
	Verified by:	<i>[Signature]</i>

MATERIAL:	SERIES 3070-HI	DATE:	6/22/15	REVISIONS:		DATE:		DRAWN BY:		COMMENTS:	
CUSTOMER:	FLEETWOOD WINDOWS AND DOORS	DRAWN BY:	BL								
JOB NAME:	FLEETWOOD TAS & AAMA TEST	JOB NUMBER:	385199-V2								

FLEETWOOD
WINDOWS AND DOORS
 1 FLEETWOOD WAY CORONA, CALIFORNIA 92709 - www.fleetwoodusa.com

SCALE: DO NOT SCALE
 DRAWING NO.: #####
 SHEET: 7 OF 9

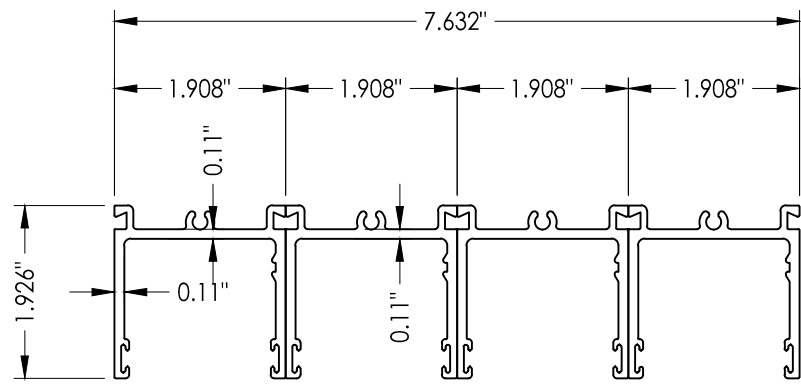

1 HEAD TRACK
(4 Single tracks)

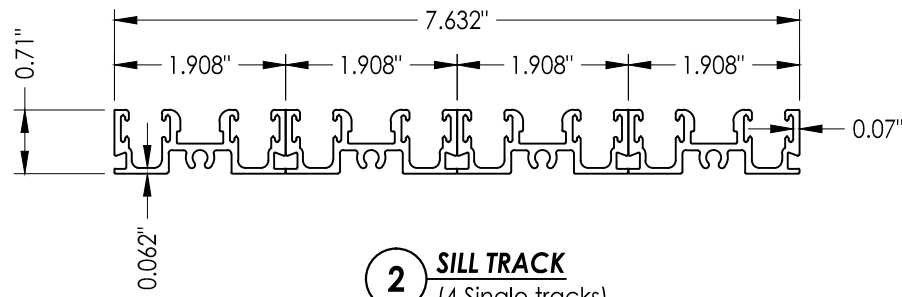

2 SILL TRACK
(4 Single tracks)

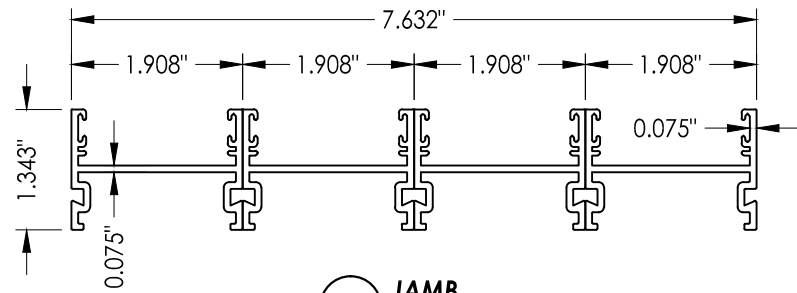

3 JAMB
(4 Single tracks)

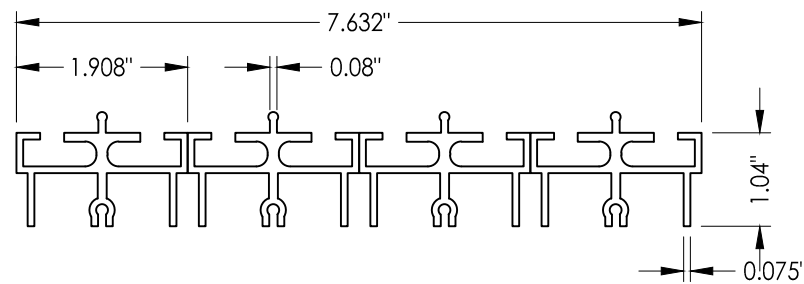

4 SUB-SILL SUPPORTS
1 HIGH X 4 WIDE

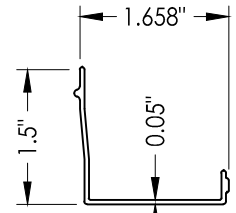

5 HEAD FILLER

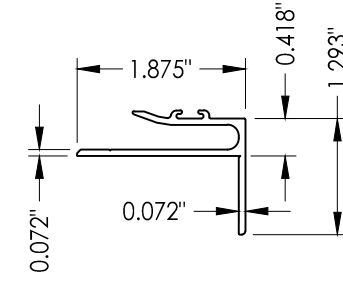

8 L-TYPE POST INTERLOCK

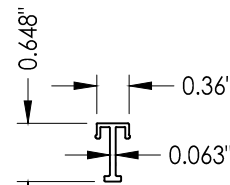

6 SILL FILLER

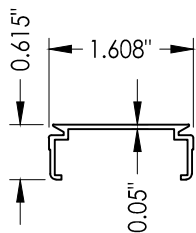

7 JAMB FILLER



10 SUB-SILLPAN
Staggered Pan
4 Track to 2 Track

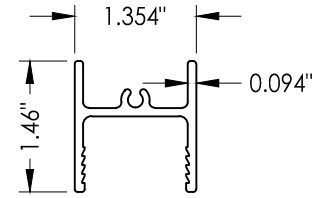

16 TOP RAIL

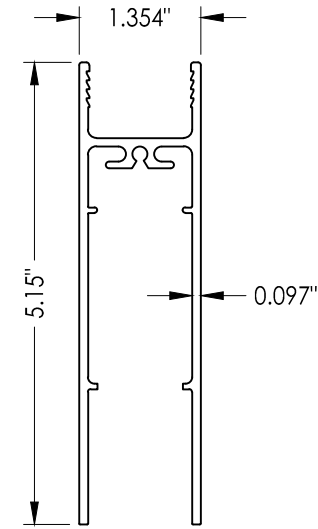

17 BOTTOM RAIL

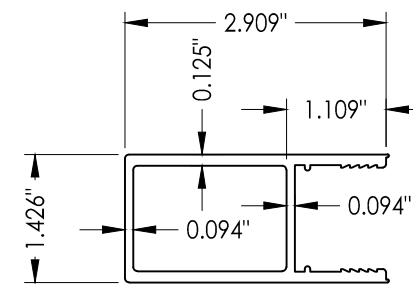

18 NARROW LOCK STILE/ WIDE FIXED STILE

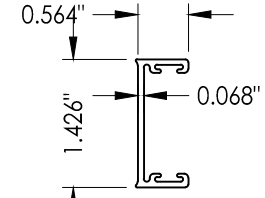

20 FEMALE YOKE

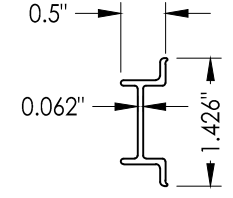

21 MALE YOKE

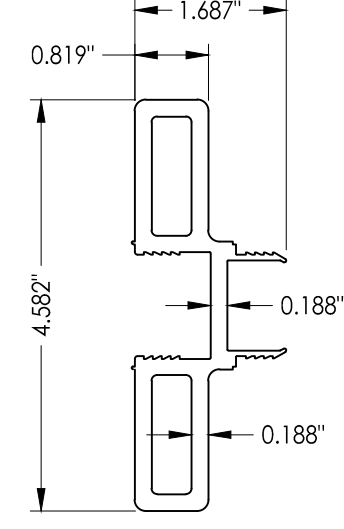

22 HP ADAPTOR

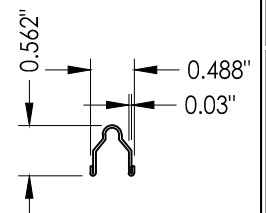

9 TRACK

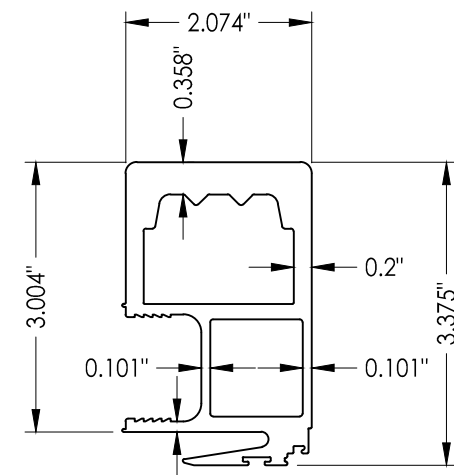

19 HP INTERLOCKER

Report #: E8391-301-44
Date: 04/01/16
Verified by: *[Signature]*

REVISIONS	DATE	DRAWN BY	COMMENTS

MATERIAL: SERIES 3070-HI	DATE: 6/22/15	DRAWN BY: BL	JOB NUMBER: 385199-V2
CUSTOMER: FLEETWOOD WINDOWS AND DOORS			
JOB NAME: FLEETWOOD TAS & AAMA TEST			

FLEETWOOD	
WINDOWS AND DOORS	
1 FLEETWOOD WAY CORONA, CALIFORNIA 92709 - www.fleetwoodusa.com	

SCALE	↓
DO NOT SCALE	
DRAWING NO.:	#####
SHEET:	8 OF 9

BILL OF MATERIALS			
ITEM #	DESCRIPTION	PART#	MATERIAL
B	2X BUCK SG >= 0.55		WOOD
C	1/4" MAX. SHIM SPACE		-
D	#10 x 2-1/2" PFH WOOD SCREW		STEEL
F	#8 x 1-1/2" PPH WOOD SCREW		STEEL
1	M/S HEAD (SINGLE TRACK)	3046	6063-T6 ALUM
2	M/S SILL (SINGLE TRACK)	3741	6063-T6 ALUM
3	JAMB (1 TRACK)	3048	6063-T6 ALUM
4	TRACK SUPPORT (SUB-SILL)	3774	6063-T6 ALUM
5	HEAD FILLER	3014	6063-T6 ALUM
6	SILL FILLER	3747	6063-T6 ALUM
7	JAMB FILLER	3710	6063-T6 ALUM
8	POST INTERLOCKER (L-TYPE)	3730	6063-T6 ALUM
9	S.S. TRACK	FW1020	STAINLESS STEEL
10	SUB-SILLPAN (1.938" DEPTH)	3722-4-4S	-
11	SMALL FIN SEAL .230	19118	-
12	9/16" GLAZING VINYL (ASTM C864)	25033	-
13	LARGE FIN SEAL .290	19117	-
14	Q-LON (U5212)	19120	-
15	Q-LON FOAM SEAL	25189	-
16	TOP RAIL	3004	6063-T6 ALUM
17	BOTTOM RAIL	3027	6063-T6 ALUM
18	NARROW LOCK STILE/WIDE FIXED STILE	3005	6063-T6 ALUM
19	HP INTERLOCKER	3034	6063-T6 ALUM
20	FEMALE YOKE	3040	6063-T6 ALUM
21	MALE YOKE	3039	6063-T6 ALUM
22	HP ADAPTOR	3716	6063-T6 ALUM
23	1" X 1" SOLID ALUMINUM	N/A	6061-T6 ALUM
24	1" X 1.25" SOLID ALUMINUM	N/A	6061-T6 ALUM
27	AIR BARRIER (SILL)	25383	SAVIO
28	AIR BARRIER (HEAD)	24097	SAVIO
29	6" AIR BARRIER FOR HP INTERLOCKER	25562	-
30	STRIKE PLATE	24980	STAINLESS STEEL
31	BACK UP PLATE	24981	STAINLESS STEEL
32	10-32 X .5" FHP	N/A	STEEL
33	#10 X 1" PHP	N/A	STEEL
34	#8 TEK X 1/2"	N/A	STEEL
35	DOW 995 SILICONE	N/A	-
42	#8 X 3/4" PPH SMS	N/A	STEEL
43	#8 X 3/4" PFH SMS	N/A	STEEL
44	#8 X 1" PFH TEK SCREW	N/A	STEEL
49	ARCHETYPE NARROW LOCK	N/A	-
51	ARCHETYPE ROLLERS	N/A	-

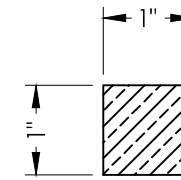

23 ALUMINUM REINFORCEMENT

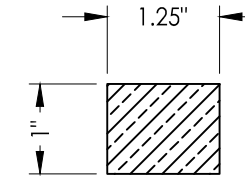

24 ALUMINUM REINFORCEMENT

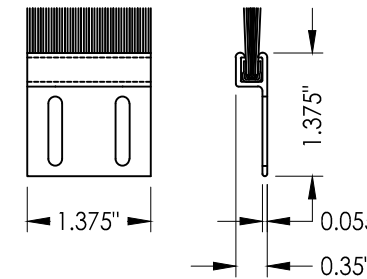

28 AIR BARRIER (HEAD)
(AT INTERLOCKERS)

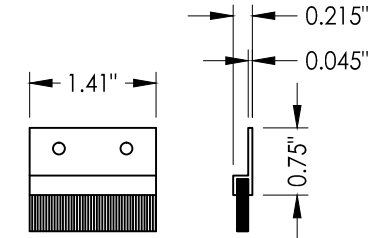

27 AIR BARRIER (SILL)
(AT INTERLOCKERS)

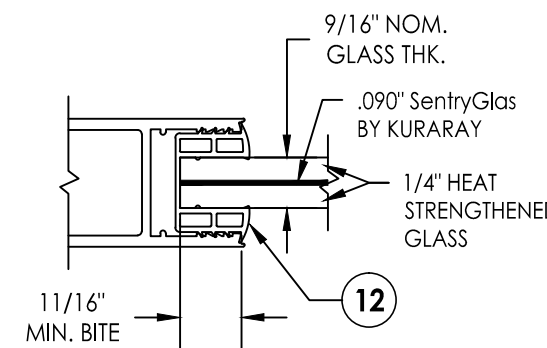

 Report #: E8391-301-44
 Date: 04/01/16
 Verified by: *[Signature]*

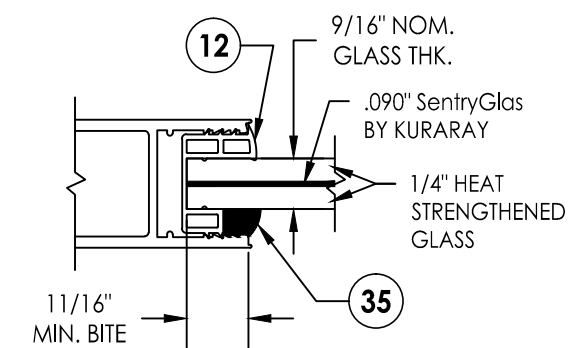

G1 GLAZING DETAIL



G2 GLAZING DETAIL

COMMENTS	
DRAWN BY	
DATE	
REVISIONS	
DATE:	6/22/15
DRAWN BY:	BL
JOB NUMBER:	385199-V2
MATERIAL:	SERIES 3070-HI
CUSTOMER:	FLEETWOOD WINDOWS AND DOORS
JOB NAME:	FLEETWOOD TAS & ANIA TEST
FLEETWOOD WINDOWS AND DOORS 1 FLEETWOOD WAY CORONA, CALIFORNIA 92709 - www.fleetwoodusa.com	
	
SCALE	↓ DO NOT SCALE
DRAWING NO.	#####
SHEET	9 OF 9