



**ASTM E1886 and ASTM E1996 TEST REPORT**

**Report No.:** E8384.02-301-18

**Rendered to:**

FLEETWOOD WINDOWS AND DOORS  
Corona, California

**PRODUCT TYPE:** Sliding Door  
**SERIES/MODEL:** 3070-HI Corner Door/Pocket Door

**This report contains in its entirety:**

**Cover Page:** 1 page  
**Report Body:** 11 pages  
**Sketch:** 1 page  
**Drawings:** 5 pages

**Test Start Date:** 07/16/15  
**Test End Date:** 11/11/15  
**Report Date:** 02/02/16  
**Revision 2 Date:** 04/01/16  
**Test Record Retention End Date:** 11/11/25

## 1.0 Client Identification:

### 1.1 Report Issued To: Fleetwood Windows & Doors

1 Fleetwood Way  
Corona, California 92879

### 1.2 Contact Person: Joe Zammit

## 2.0 Laboratory Identification:

### 2.1 Test Laboratory: Architectural Testing, Inc., an Intertek company ("Intertek-ATI")

2524 East Jensen Avenue  
Fresno, California 93706

### 2.2 Phone Number: (559) 233-8705

## 3.0 Project Summary:

### 3.1 Product Type: Sliding Door

### 3.2 Series/Model: 3070-HI Corner Door/Pocket Door

**3.3 Compliance Statement:** Results obtained are tested values and were secured by using the designated test method(s). The specimen(s) tested met the performance requirements set forth in the referenced test procedures for a **+2400/-2640 Pa (+50.13/-55.14psf) Design Pressure** with missile impacts corresponding to Missile Level D and Wind Zone 4.

*NOTE: One corner door sample tested. Reference test report E8391.02-301-18 for the flat door configuration with three samples tested as outlined in the ASTM E1996 test standard.*

### 3.4 Test Dates: 07/16/15 - 11/11/15

**3.5 Test Record Retention End Date:** All test records for this report will be retained until November 11, 2025.

**3.6 Test Location:** Architectural Testing, Inc. test facility in Fresno, California.

**3.7 Test Specimen Source:** The test specimen(s) was provided by the client. Representative samples of the test specimen(s) will be retained by Architectural Testing for a minimum of four years from the test completion date.

**3.8 Drawing Reference:** The test specimen drawings have been reviewed by Architectural Testing and are representative of the test specimen(s) reported herein. Test specimen construction was verified by Architectural Testing per the drawings located in Appendix B. Any deviations are documented herein or on the drawings.

### 3.0 Project Summary: (Continued)

#### 3.9 List of Official Observers:

<u>Name</u>	<u>Company</u>
Nathan Baker	Fleetwood
Dennis Janzen	Intertek-ATI
Tyler Westerling	Intertek-ATI

#### 4.0 Test Protocol(s):

*ASTM E1886-13a, Standard Test Method for Performance of Exterior Windows, Curtain Walls, Doors, and Impact Protective Systems Impacted by Missile(s) and Exposed to Cyclic Pressure Differentials*

*ASTM E1996-14a, Standard Specification for Performance of Exterior Windows, Curtain Walls, Doors, and Impact Protective Systems Impacted by Windborne Debris in Hurricanes*

**5.0 Test Specimen Description:**

**5.1 Product Sizes:**

Overall Area: 22.8 m <sup>2</sup> (243 ft <sup>2</sup> )	Width		Height	
	millimeters	inches	millimeters	inches
MAX Pocket wall size	4,572	180	3,658	144
MAX 90 Degree Corner wall size	4,572	180	3,658	144
MAX 135 Degree Corner wall size	3,048	120	3,658	144
MAX Panel size	1,588	62-1/16	3,607	142

*The following descriptions apply to all specimens.*

**5.2 Frame Construction:**

Frame Member	Material	Description
Sill	Aluminum	Three piece sill
Sill pan	Aluminum	With a 3" tall interior leg
Sill filler	Aluminum	Snapped in place where panels do not slide
Jamb	Aluminum	With snapped in jamb filler where panel is not engaged
Head	Aluminum	With snapped in head filler where panel is not engaged

	Joinery Type	Detail
All corners	Butt	Sealed with silicone and attached with three #10 x 3/4" Phillips pan head sheet metal screws.

**5.0 Test Specimen Description: (Continued)**

**5.3 Panel Construction:**

Panel Member	Material	Description
All	Aluminum	See drawings for details.

	Joinery Type	Detail
All corners	Butt	Sealed with silicone. Top corners fastened with one #10 x 2" Phillips head screw each. Bottom corners fastened with one #10 x 2". Two 1/4-20 x 1" Phillips head screws were fastened into each roller.

**5.4 Weatherstripping:**

Description	Quantity	Location
0.230 polypile with center fin	4	In sill contracting interior and exterior of each panel leg
0.230 polypile with center fin	2	In head contracting interior and exterior of panel face
0.290 Polypile with center fin	1	In each pocket interlock extrusion
0.230 polypile with center fin	2	In interior and exterior meeting stile locking extrusion
0.290 polypile with center fin	1	In each interlock extrusion
Q-lon foam seal	1	In interior and exterior of jamb extrusion
Panel corner air barrier	1	At each exposed panel bottom and top corner

### 5.0 Test Specimen Description: (Continued)

**5.5 Glazing:** *No conclusions of any kind regarding the adequacy or inadequacy of the glass in any glazed test specimen(s) can be made.*

Glass Type	Glazing	Glazing Method
Monolithic	6mm clear/0.090 SGP/6mm clear	Channel glazed into frame. Dry glazed at all top and bottom rails and interlocks. Wet glazed at locking vertical stiles only

Location	Quantity	Daylight Opening		Glass Bite
		millimeters	inches	
All Lights	8	1435 x 3454	56-1/2 x 136	5/8

### 5.6 Drainage:

Drainage Method	Size	Quantity	Location
Weep Notch	1" wide by 3/16" tall	6	6" from the end of each sill member

### 5.7 Hardware:

Description	Quantity	Location
Rollers, Tandem	2 tandem rollers each panel	Bottom panel rail
Archetype narrow Lock	2	Locking meeting panel
Archetype II Lock	1	Locking meeting panel

## 5.0 Test Specimen Description: (Continued)

### 5.8 Reinforcement:

Drawing Number	Location	Material
37	All small interlock hallows	Aluminum
38	All small interlock hallows	Aluminum

**5.9 Screen Construction:** No screen was utilized.

### 6.0 Installation:

The specimen was installed into a Pine wood buck. The rough opening allowed for a 1/4" shim space. The exterior perimeter of the window was sealed with sealant. See drawing on sheet 8 of 12 for installation details.

**7.0 Test Results:** (Continued) The temperature during testing was 65°F. Results are tabulated as follows:

**ASTM E1886, Large**

**Conditioning Temperature:** 18°C (65°F)

**Missile Weight:** 4080 g (9.0 lbs)

**Missile Length:** 2.4 m (8' 0")

**Muzzle Distance from Test Specimen:** 5.2 m (17' 0")

**Test Unit #1:** Orientation within ±5° of horizontal

<b>Impact #1:</b> Missile Velocity: 15.3 m/s (50.2fps)	
<b>Impact Area:</b>	Center of 90 degree meeting stile
<b>Observations:</b>	Missile hit target area
<b>Results:</b>	Pass

<b>Impact #2:</b> Missile Velocity: 15.4 m/s (50.4 fps)	
<b>Impact Area:</b>	Center of center panel between 90 deg and 135 corner
<b>Observations:</b>	Missile hit target area
<b>Results:</b>	Pass

<b>Impact #3:</b> Missile Velocity: 15.2 m/s (49.8fps)	
<b>Impact Area:</b>	Bottom right hand corner of center panel between 90 deg and 135 corner
<b>Observations:</b>	Missile hit target area
<b>Results:</b>	Pass

<b>Impact #4:</b> Missile Velocity: 15.1 m/s (49.6 fps)	
<b>Impact Area:</b>	Center of right hand panel between 90 deg and 135 corner
<b>Observations:</b>	Missile hit target area
<b>Results:</b>	Pass

<b>Impact #5:</b> Missile Velocity: 15.3 m/s (50.1fps)	
<b>Impact Area:</b>	Top left hand corner of right hand panel between 90 deg and 135 corner
<b>Observations:</b>	Missile hit target area
<b>Results:</b>	Pass

## 7.0 Test Results: (Continued)

### 7.3 Protocol TAS 201-94, *Large Impact Procedures* (Continued)

#### Test Unit #1: Orientation within $\pm 5^\circ$ of horizontal (Continued)

<b>Impact #6: Missile Velocity: 15.2 m/s (49.8 fps)</b>	
<b>Impact Area:</b>	Center 135 degree meeting stile
<b>Observations:</b>	Missile hit target area
<b>Results:</b>	Pass

<b>Impact #7: Missile Velocity: 15.2 m/s (49.8fps)</b>	
<b>Impact Area:</b>	Top right corner of panel to the right of the 135 degree corner
<b>Observations:</b>	Missile hit target area
<b>Results:</b>	Pass

<b>Impact #8: Missile Velocity: 15.3 m/s (50.3 fps)</b>	
<b>Impact Area:</b>	Bottom left corner of panel to the right of the 135 degree corner
<b>Observations:</b>	Missile hit target area
<b>Results:</b>	Pass

<b>Impact #9: Missile Velocity: 15.3 m/s (50.1 fps)</b>	
<b>Impact Area:</b>	Center of interlock between 135 degree corner stile and jamb
<b>Observations:</b>	Missile hit target area
<b>Results:</b>	Pass

**7.0 Test Results:** (Continued) The temperature during ASTM E1886 testing was 65°F. Results are tabulated as follows:

**ASTM E1886, Air Pressure Cycling**

**Test Unit #1**

**Design Pressure:** a +2640/-2880 Pa (+50/-55psf)

**POSITIVE PRESSURE**

Pressure Range (psf)	Number of Cycles	Average Cycle Time (seconds)	Observations
10 to 25	3500	2.88	
0 to 30	300	4.62	
25 to 40	600	2.74	
15 to 50	100	4.83	

**NEGATIVE PRESSURE**

Pressure Range (psf)	Number of Cycles	Average Cycle Time (seconds)	Observations
16.5 to 55	50	4.89	
27.5 to 44	1050	2.91	
0 to 33	50	3.54	
11 to 27.5	3350	2.94	

**Result:** Pass

**Conclusion:** Intertek-ATI observed no signs of failure in any area of the test specimens during the cyclic load test; as such, the test specimens satisfy the cyclic load requirements of TAS 203.

## 8.0 Test Equipment:

**Canon:** Constructed from steel piping utilizing compressed air to propel the missile

**Missile:** 2x4 Southern Pine

**Timing Device:** Electronic beam type

**Cycling Mechanism:** Computer controlled centrifugal blower with electronic pressure measuring device

**Deflection Measuring Device:** Linear transducers

**Laboratory Compliance Statements:** The following are provided as required by the protocols for the testing reported herein:

Upon completion of testing, specimens tested for TAS 201-94 met the requirements of Section 1626 of the Florida Building Code, Building.

AND

Upon completion of testing, specimens tested for TAS 202-94 met the requirements of Section 1620 of the Florida Building Code, Building.

AND

Upon completion of testing, specimens tested for TAS 203-94 met the requirements of Section 1626 of the Florida Building Code, Building.

Tape and film were used to seal against air leakage during structural testing. In our opinion, the tape and film did not influence the results of the test.

Intertek-ATI will service this report for the entire test record retention period. Test records such as detailed drawings, datasheets, representative samples of test specimens, or other pertinent project documentation, will be retained by Intertek-ATI for the entire test record retention period.

This report does not constitute certification of this product nor an opinion or endorsement by this laboratory. It is the exclusive property of the client so named herein and relates only to the specimen(s) tested. This report may not be reproduced, except in full, without the written approval of Intertek-ATI.

For ARCHITECTURAL TESTING, INC.:

---

Dennis Janzen  
Technician

---

Tyler Westerling, P.E.  
Senior Project Engineer

TW:ss

Attachments (pages): This report is complete only when all attachments listed are included.

Appendix A: Sketches (1)

Appendix B: Drawings (12)

This report produced from controlled document template ATI 00651, revised 07/08/15.

### Revision Log

<u>Rev. #</u>	<u>Date</u>	<u>Page(s)</u>	<u>Revision(s)</u>
0	02/02/16	N/A	Original report issue.
1	02/09/16	Appendix B	Revised drawings.
2	04/01/16	4	Corrected panel corner detail.
2	04/01/16	6	Corrected installation details.
2	04/01/16	Appendix B	Updated drawing package.

This report produced from controlled document template ATI 00651, revised 07/08/15.

## Appendix A

### Sketch

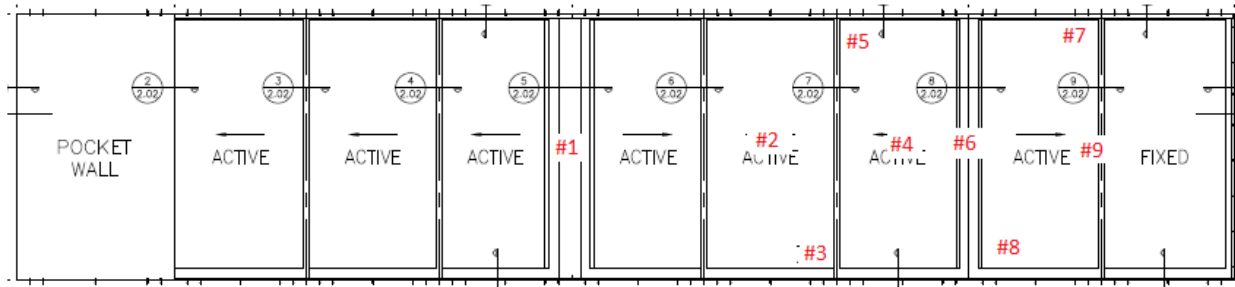

Sketch #1 Impact Locations

## **Appendix B**

### **Drawings**

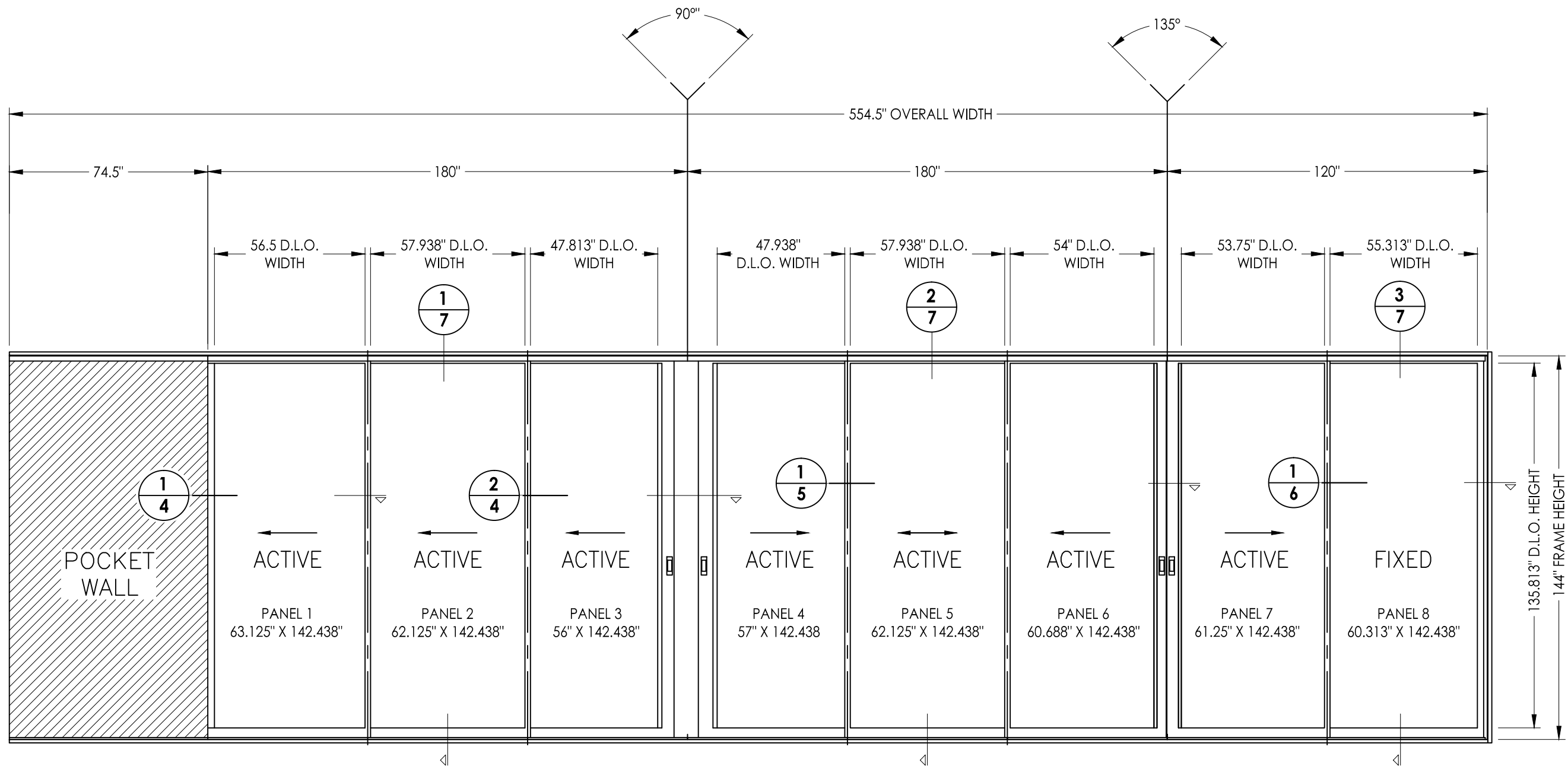

TEST ELEVATION (SILL PAN NOT SHOWN)

TABLE OF CONTENTS	
SHEET #	DESCRIPTION
1	Table of contents and test elevation
2	Panel details
3	Panel details
4	Horizontal cross section
5	Horizontal cross section
6	Horizontal cross section
7	Vertical cross sections
8	Frame anchoring
9	Hardware components
10	Hardware components
11	Components
12	Bill of materials, components and glazing details

 Report #: E8384-301-44  
 Date: 04/01/16  
 Verified by: *[Signature]*

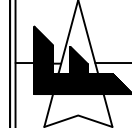
COMMENTS	
DRAWN BY	
DATE	
REVISIONS	
DATE:	6/22/15
DRAWN BY:	BL
JOB NUMBER:	385199-V2
MATERIAL:	SERIES 3070-HI
CUSTOMER:	FLEETWOOD WINDOWS AND DOORS
JOB NAME:	FLEETWOOD TAS & AAMA TEST
	
	
SCALE ↓ DO NOT SCALE	
DRAWING NO. #	
SHEET 1 OF 12	

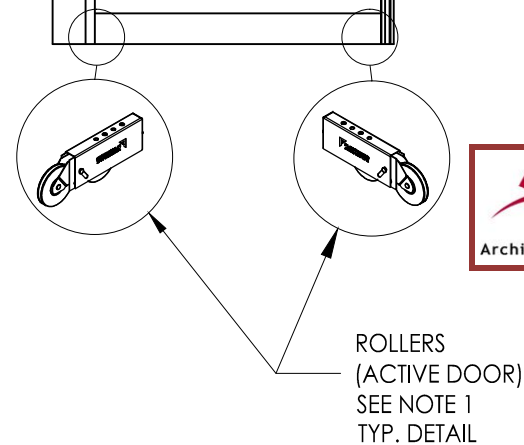
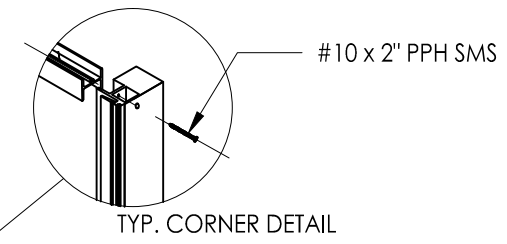
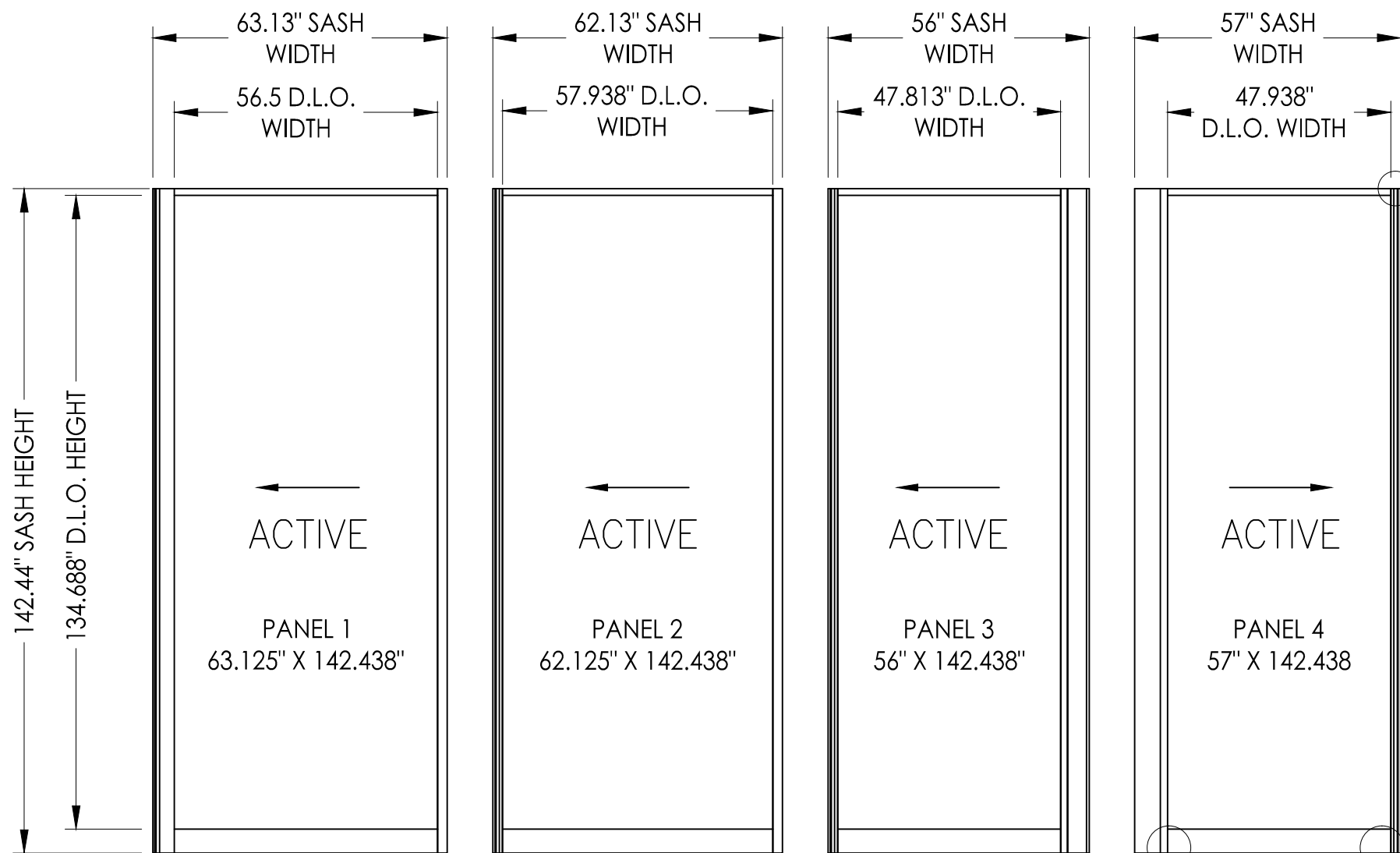

Report #: E8384-301-44  
 Date: 04/01/16  
 Verified by: *[Signature]*

Note:  
 1. Roller attached to bottom rail utilizing (2) 1/4-20 x 1/2\"/>

COMMENTS					
DRAWN BY					
DATE					
REVISIONS					
DATE:	6/22/15	JOB NUMBER:	385199-V2		
DRAWN BY:	BL				
MATERIAL:	SERIES 3070-HI	CUSTOMER:	FLEETWOOD WINDOWS AND DOORS		
		JOB NAME:	FLEETWOOD TAS & AAMA TEST		
<b>FLEETWOOD</b> <b>WINDOWS AND DOORS</b> <small>1 FLEETWOOD WAY CORONA, CALIFORNIA 92709 - www.fleetwoodusa.com</small>					
SCALE: DO NOT SCALE					
DRAWING NO. #					
SHEET 2 OF 12					

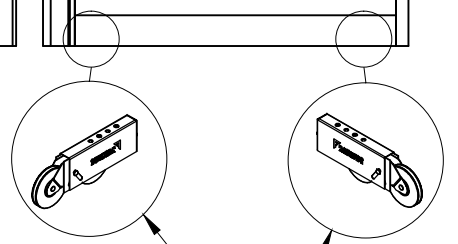
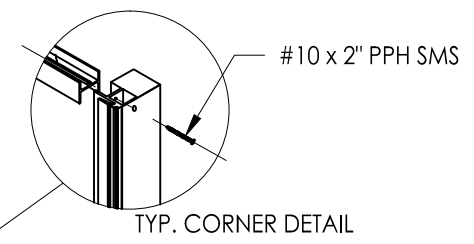
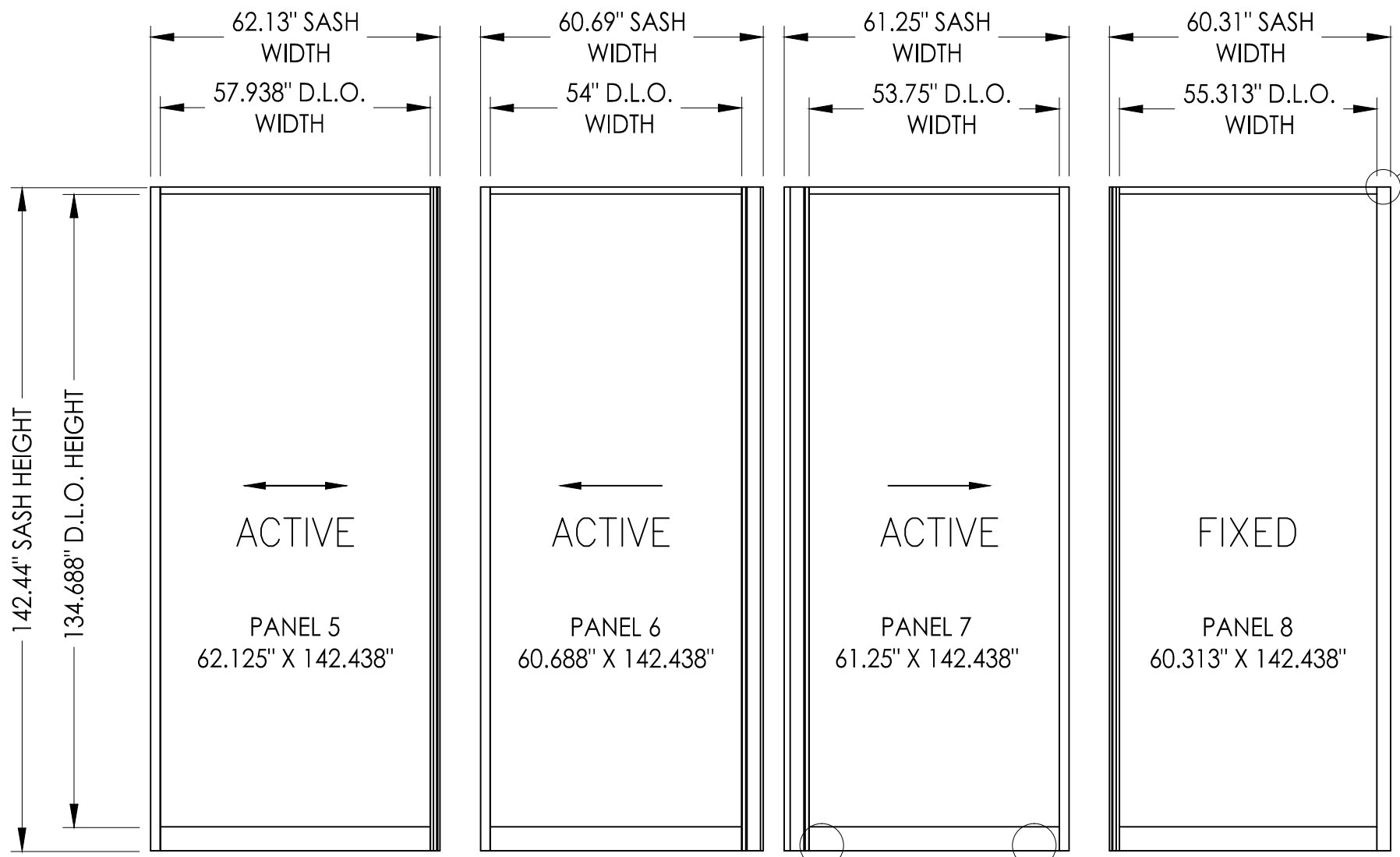

ROLLERS  
(ACTIVE DOOR)  
SEE NOTE 1  
TYP. DETAIL

Note:  
1. Roller attached to bottom rail utilizing (2) 1/4-20 x 1/2\"/>

	Report #:	E8384-301-44
	Date:	04/01/16
	Verified by:	<i>[Signature]</i>

REVISIONS	DATE	DRAWN BY	COMMENTS
MATERIAL:	SERIES 3070-HI	CUSTOMER: FLEETWOOD WINDOWS AND DOORS	
		JOB NAME: FLEETWOOD TAS & AAMA TEST	
DATE:	6/22/15	JOB NUMBER:	385199-V2
DRAWN BY:	BL		
<b>FLEETWOOD</b> <b>WINDOWS AND DOORS</b> <small>1 FLEETWOOD WAY CORONA, CALIFORNIA 92729 - www.fleetwoodusa.com</small>			
SCALE: DO NOT SCALE			
DRAWING NO. #			
SHEET 3 OF 12			

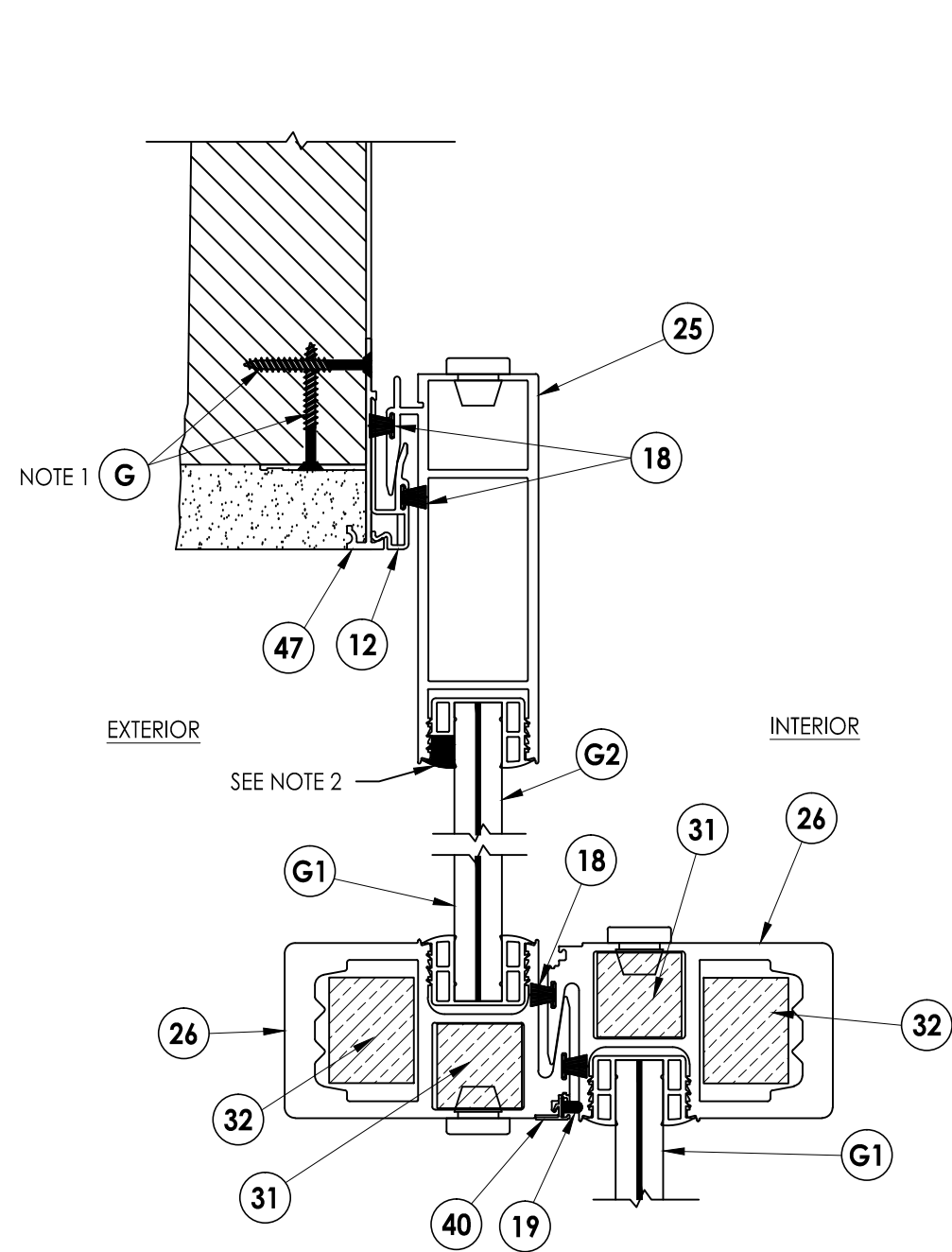

1  
4 HORIZONTAL CROSS SECTION

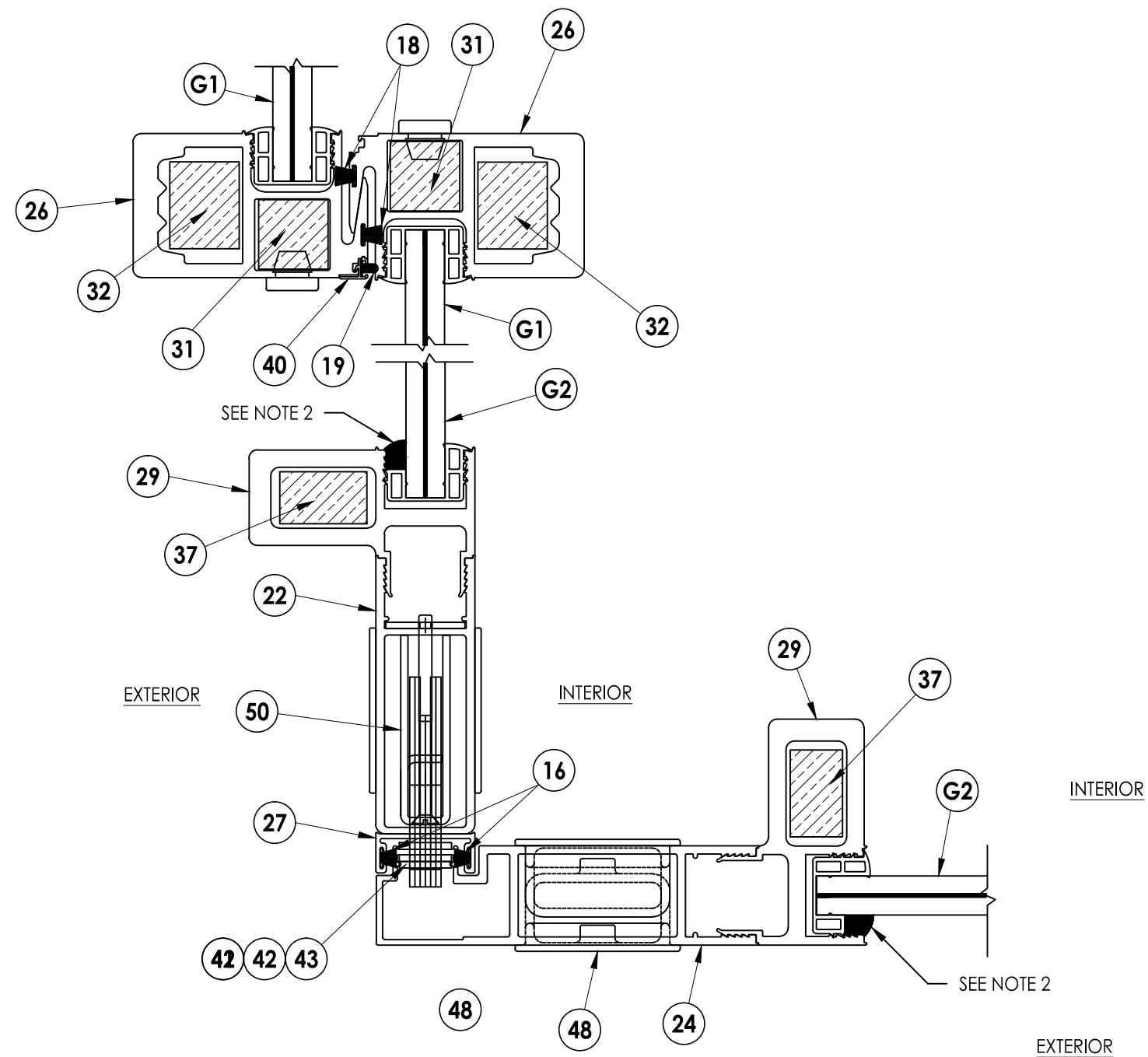

2  
4 HORIZONTAL CROSS SECTION

NOTE:  
 1. 8" from each end then 12" on center  
 2. Interior or exterior (gasket cut 2" from top rail and bottom rail on stile).

	Report #:	E8384-301-44
	Date:	04/01/16
	Verified by:	<i>[Signature]</i>

COMMENTS	
DRAWN BY	
DATE	
REVISIONS	
DATE:	6/22/15
DRAWN BY:	BL
JOB NUMBER:	385199-V2
MATERIAL:	SERIES 3070-HI
CUSTOMER:	FLEETWOOD WINDOWS AND DOORS
JOB NAME:	FLEETWOOD TAS & AAMA TEST
<b>FLEETWOOD</b> <b>WINDOWS AND DOORS</b> <small>1 FLEETWOOD WAY CORONA, CALIFORNIA 92709 - www.fleetwoodusa.com</small>	
	
SCALE	↓ DO NOT SCALE
DRAWING NO.	↓ #
SHEET	↓ 4 OF 12

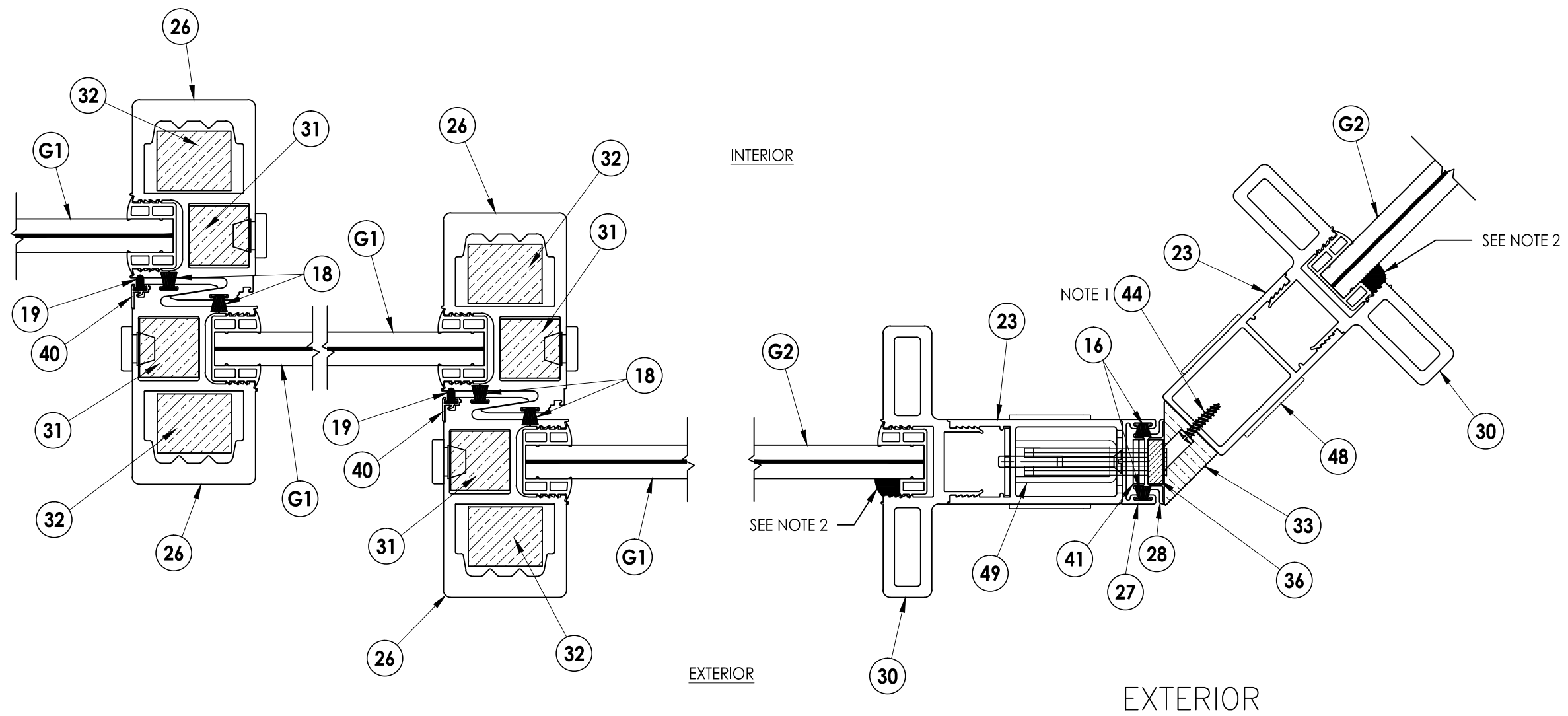

1  
5 HORIZONTAL CROSS SECTION

NOTE:  
 1. 6" from each end then 18" on center  
 2. Interior or exterior (gasket cut 2" from top rail and bottom rail on stile).

 Architectural Testing	Report #:	E8384-301-44
	Date:	04/01/16
	Verified by:	<i>[Signature]</i>

REVISIONS	DATE	DRAWN BY	COMMENTS
DATE:	6/22/15	JOB NUMBER:	385199-V2
DRAWN BY:	BL		
MATERIAL:	SERIES 3070-HI		
CUSTOMER:	FLEETWOOD WINDOWS AND DOORS		
JOB NAME:	FLEETWOOD TAS & AAMA TEST		
<b>FLEETWOOD</b> <b>WINDOWS AND DOORS</b> <small>1 FLEETWOOD WAY CORONA, CALIFORNIA 92779 - www.fleetwoodusa.com</small>			
			
SCALE ↓ DO NOT SCALE			
DRAWING NO. ↓ #			
SHEET ↓ 5 OF 12			

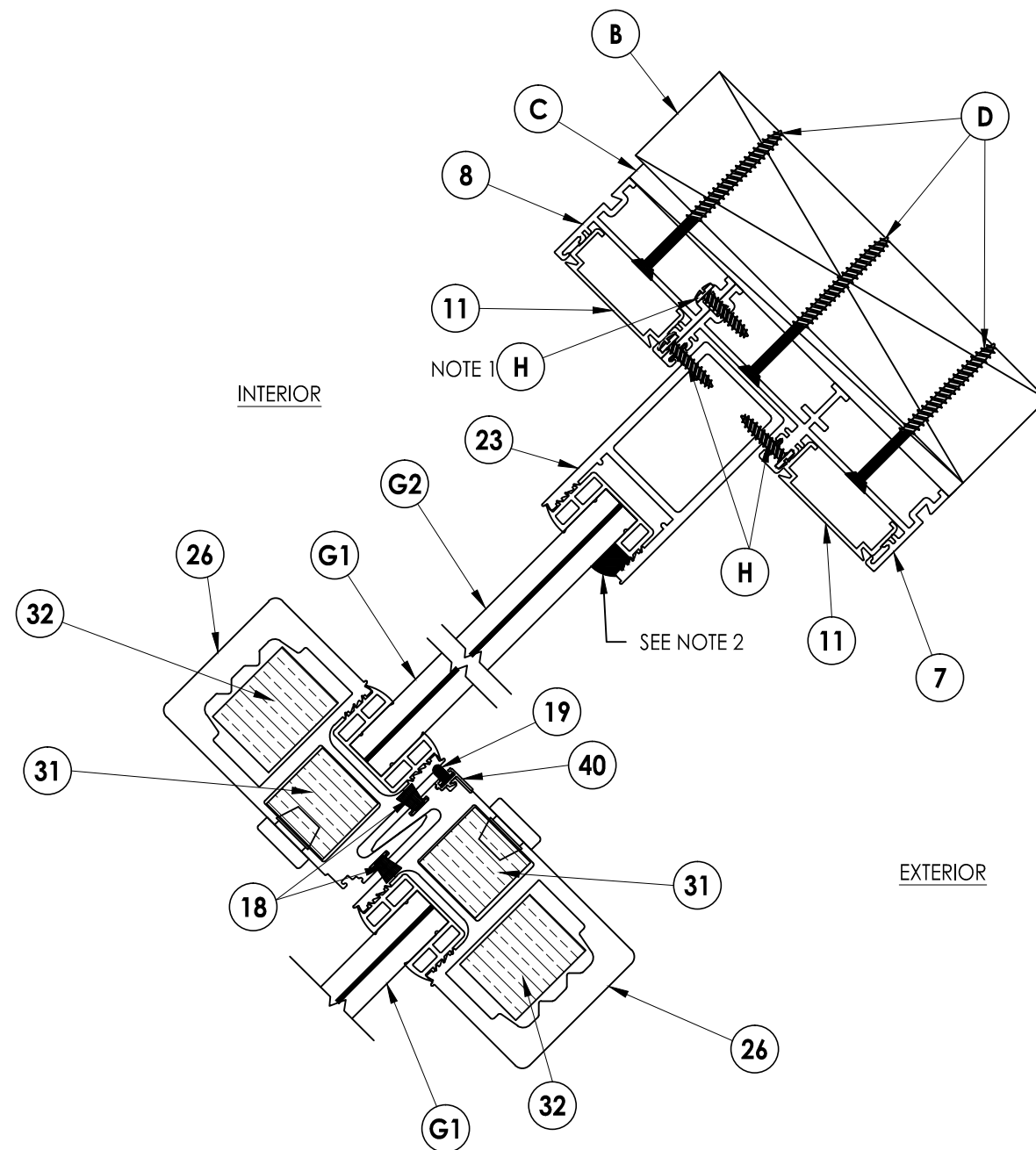

1  
6 **HORIZONTAL CROSS SECTION**

NOTE:  
 1. 1" from each end then 60" on center  
 2. Interior or exterior (gasket cut 2" from top rail and bottom rail on stile).

 Architectural Testing	Report #:	E8384-301-44
	Date:	04/01/16
	Verified by:	<i>[Signature]</i>

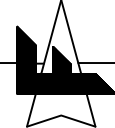
MATERIAL:	SERIES 3070-HI	DATE:	6/22/15	REVISIONS		COMMENTS	
CUSTOMER:	FLEETWOOD WINDOWS AND DOORS	DRAWN BY:	BL				
JOB NAME:	FLEETWOOD TAS & AAMA TEST	JOB NUMBER:	385199-V2				
<b>FLEETWOOD</b> <b>WINDOWS AND DOORS</b> <small>1 FLEETWOOD WAY CORONA, CALIFORNIA 92709 - www.fleetwoodusa.com</small>				SCALE ↓ DO NOT SCALE		DRAWING NO. ↓ #	
		SHEET ↓ 6 OF 12					

NOTE:  
1. 1" from each end then  
60" on center

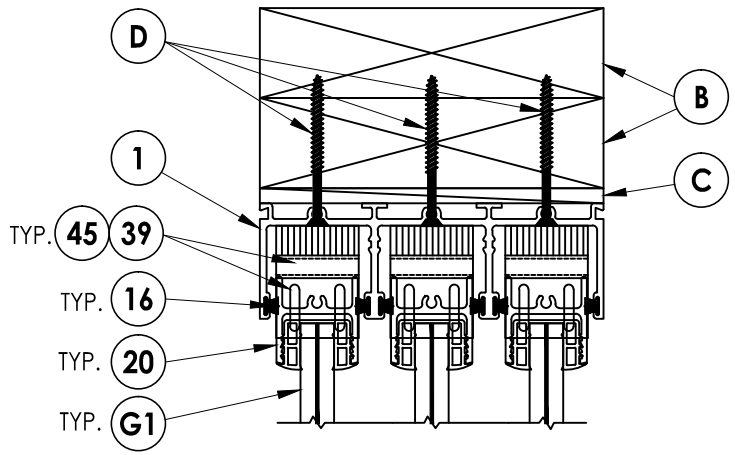

EXTERIOR

INTERIOR

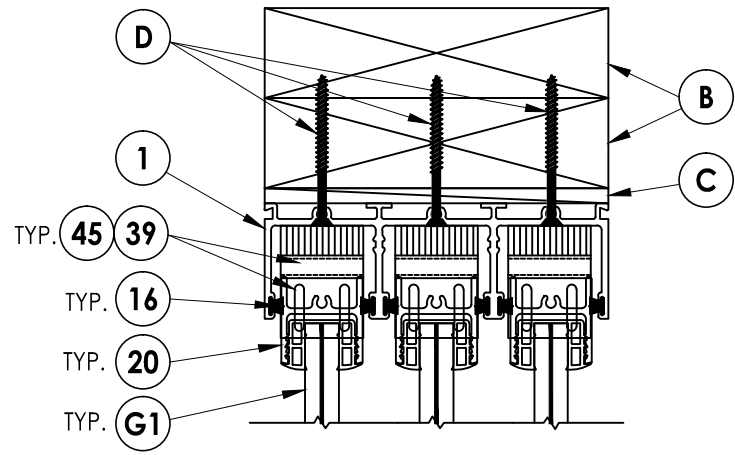

EXTERIOR

INTERIOR

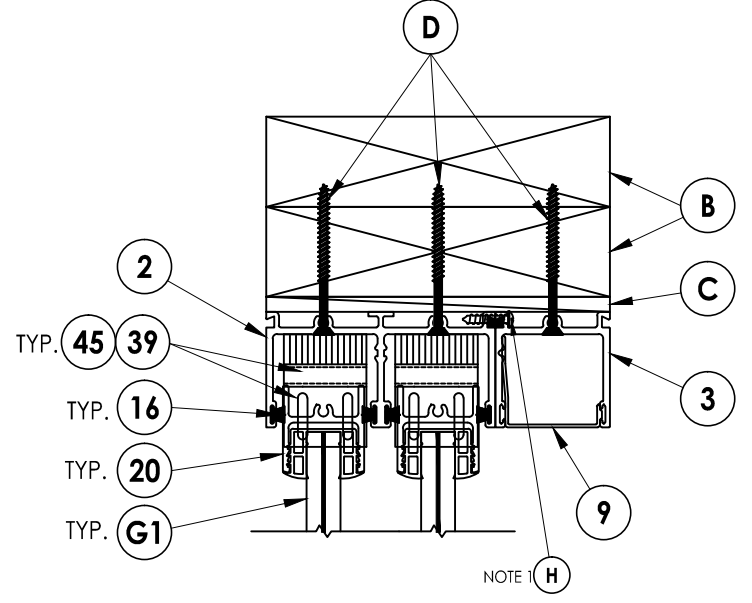

EXTERIOR

INTERIOR

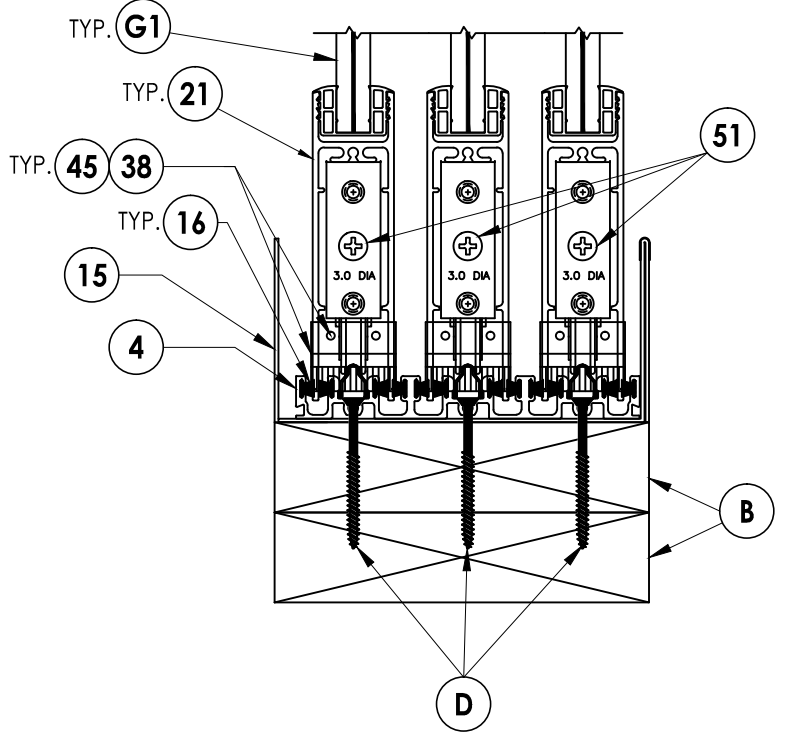

**1** VERTICAL CROSS SECTION  
**7**

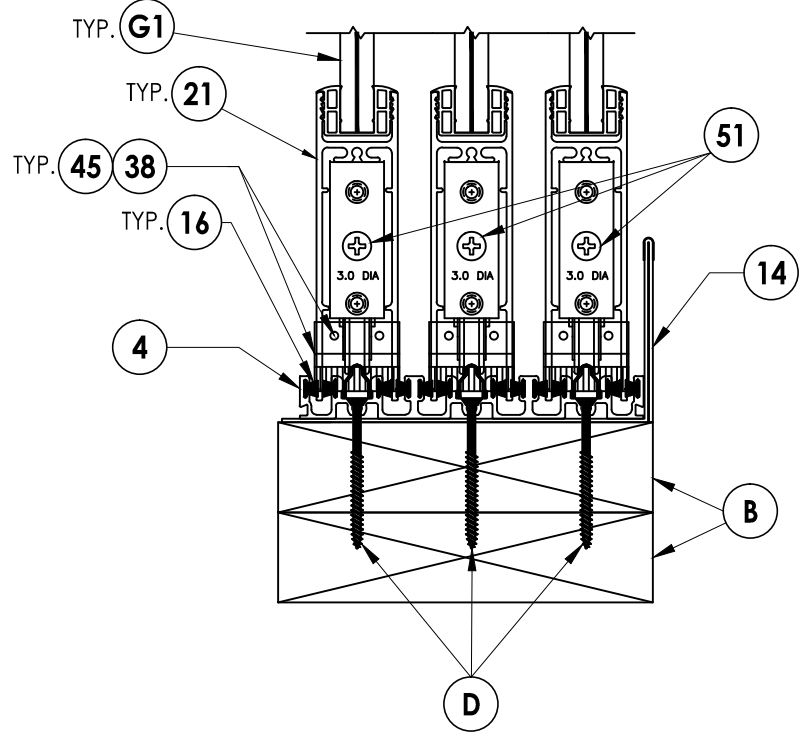

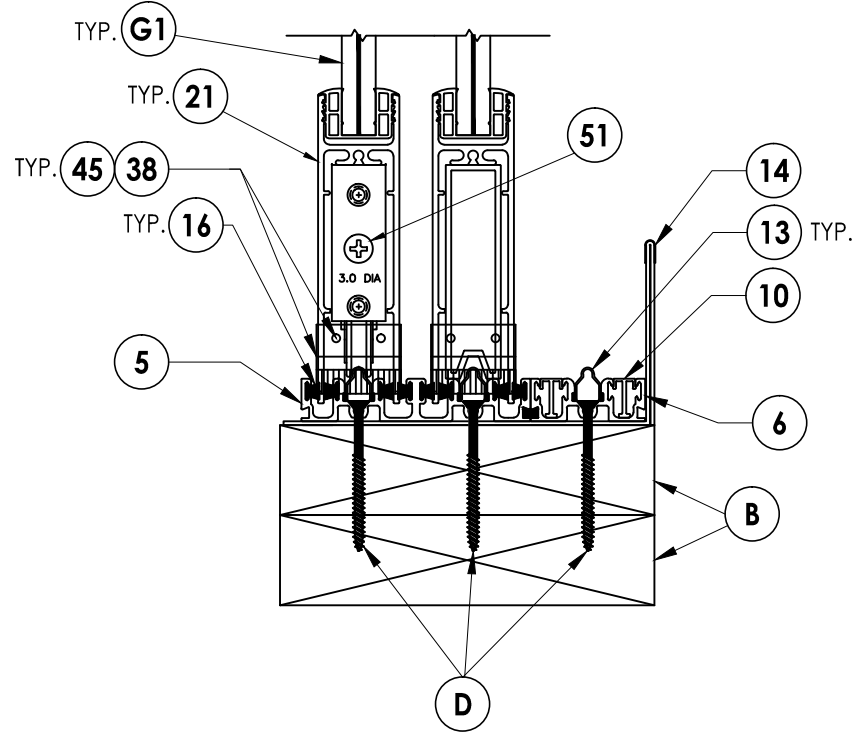

**2** VERTICAL CROSS SECTION  
**7**

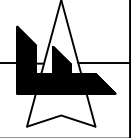

**3** VERTICAL CROSS SECTION  
**7**

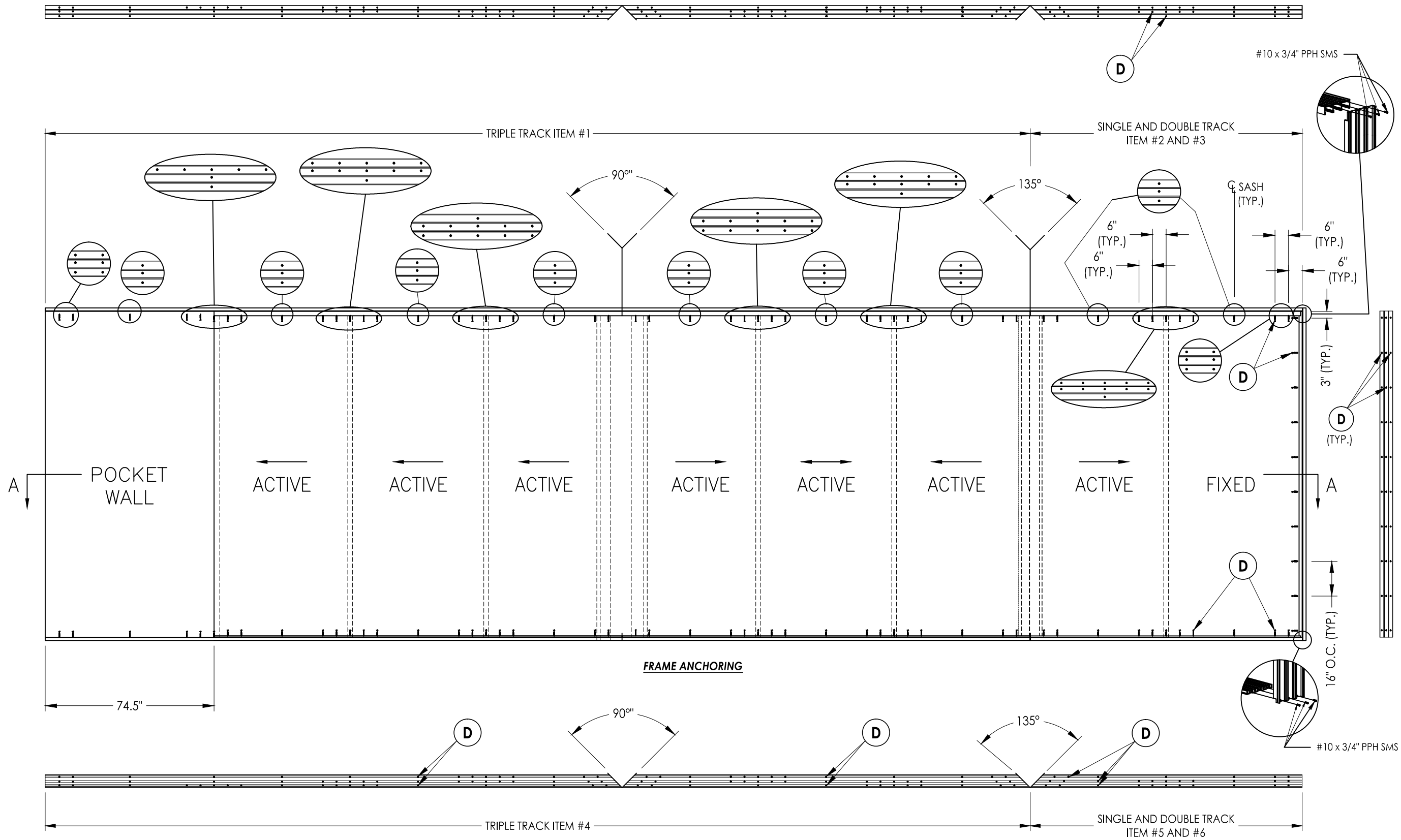
COMMENTS				
DRAWN BY				
DATE				
REVISIONS				
DATE:	6/22/15			
DRAWN BY:	BL			
JOB NUMBER:	385199-V2			
MATERIAL:	SERIES 3070-HI			
CUSTOMER:	FLEETWOOD WINDOWS AND DOORS			
JOB NAME:	FLEETWOOD TAS & AAMA TEST			
 FLEETWOOD WINDOWS AND DOORS <small>1 FLEETWOOD WAY CORONA, CALIFORNIA 92709 - www.fleetwoodusa.com</small>				
				
SCALE ↓ DO NOT SCALE				
DRAWING NO. ↓ #				
SHEET ↓ 7 OF 12				

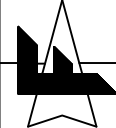

COMMENTS					
DRAWN BY					
DATE					
REVISIONS					
DATE:	6/22/15				
DRAWN BY:	BL				
JOB NUMBER:	385199-V2				
MATERIAL:	SERIES 3070-HI				
CUSTOMER:	FLEETWOOD WINDOWS AND DOORS				
JOB NAME:	FLEETWOOD TAS & AAMA TEST				
 FLEETWOOD WAY CORONA, CALIFORNIA 92709 - www.fleetwoodusa.com					
					
SCALE: DO NOT SCALE					
DRAWING NO. #					
SHEET 8 OF 12					



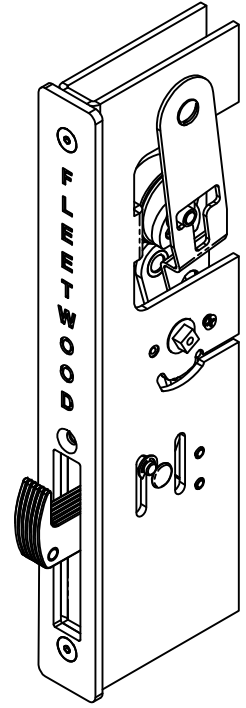
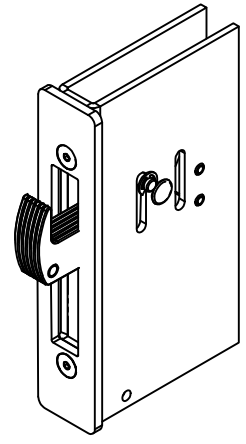
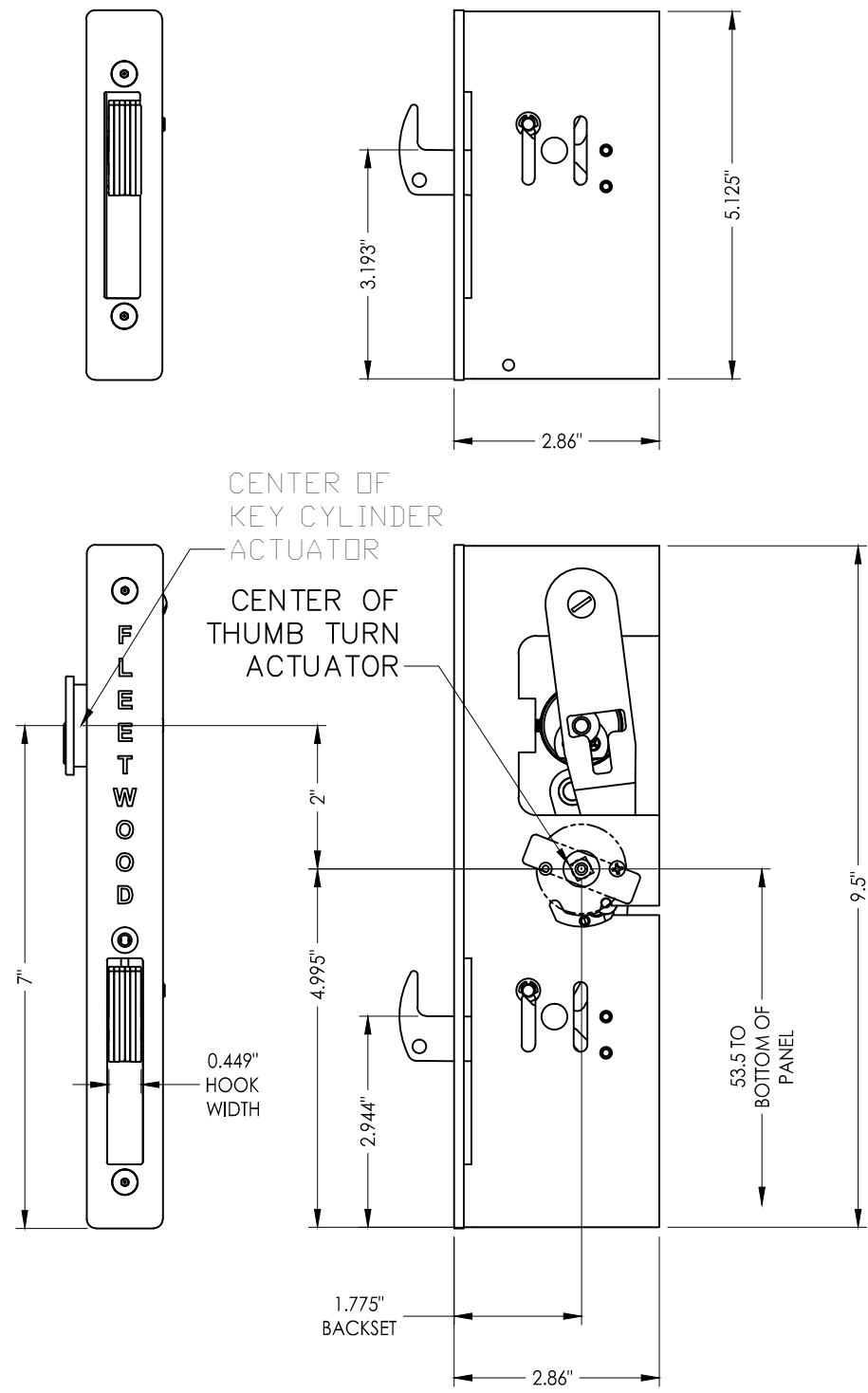

50 ARCHETYPE LOCK

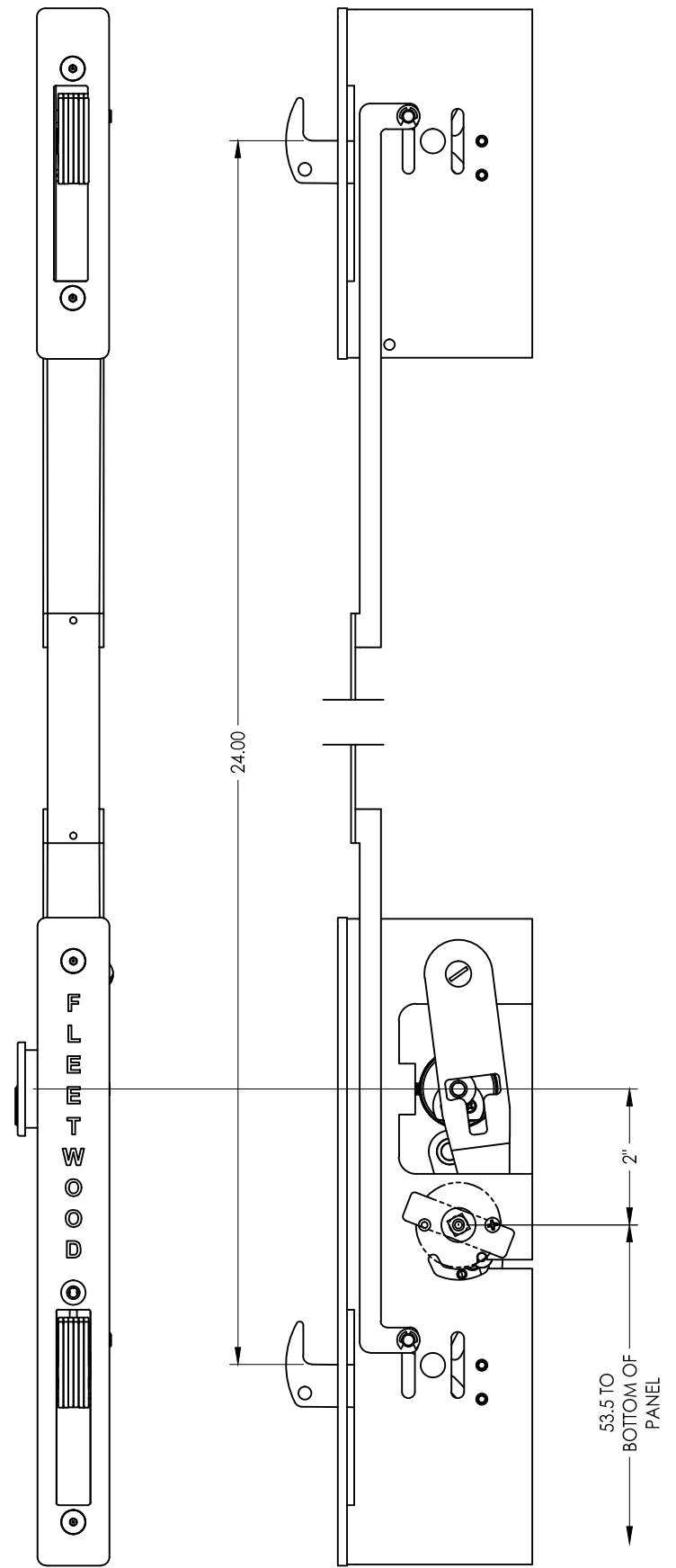

MATERIAL: SERIES 3070-HI		DATE: 6/22/15	REVISIONS	DATE	DRAWN BY	COMMENTS
CUSTOMER: FLEETWOOD WINDOWS AND DOORS		DATE: 04/01/16				
JOB NAME: FLEETWOOD TAS & AAMA TEST		JOB NUMBER: 385199-V2				
 <b>FLEETWOOD</b> <b>WINDOWS AND DOORS</b> <small>1 FLEETWOOD WAY CORONA, CALIFORNIA 92779 - www.fleetwoodusa.com</small>						
SCALE: DO NOT SCALE		DRAWING NO.:				
#						
SHEET: 10 OF 12						

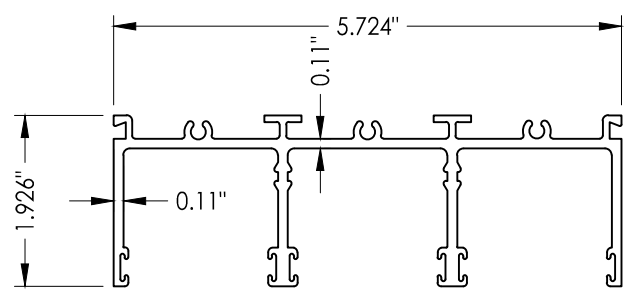

**1 HEAD TRACK**  
(3 Track)

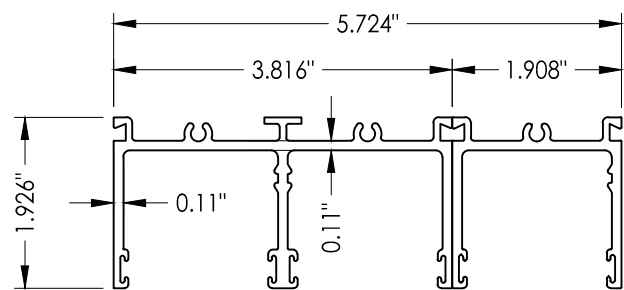

**2 HEAD TRACK**  
(2 Track)

**3 HEAD TRACK**  
(Single Track)

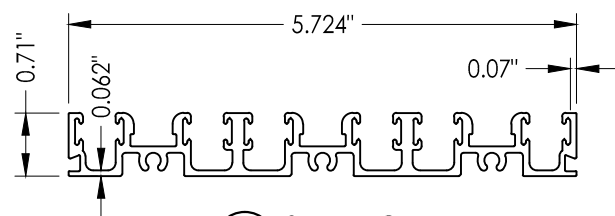

**4 SILL TRACK**  
(3 Tracks)

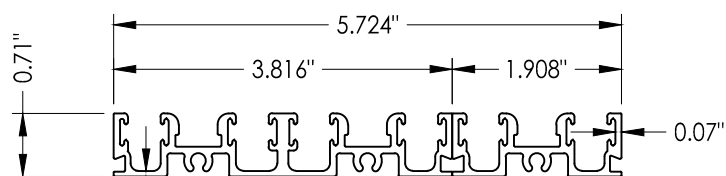

**5 SILL TRACK**  
(2 Tracks)

**6 SILL TRACK**  
(Single Track)

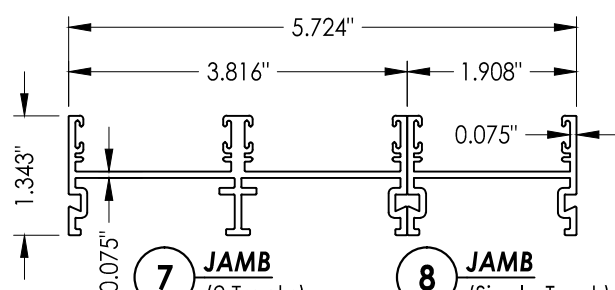

**7 JAMB**  
(2 Tracks)

**8 JAMB**  
(Single Track)

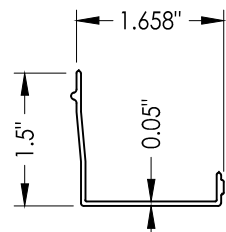

**9 HEAD FILLER**

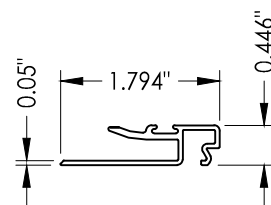

**12 J-TYPE POST INTERLOCK**

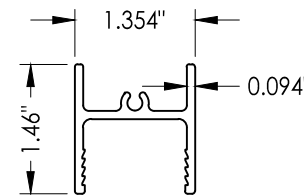

**20 TOP RAIL**

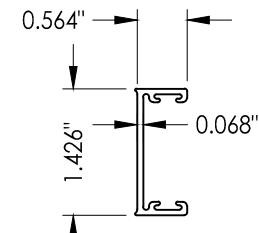

**27 FEMALE YOKE**

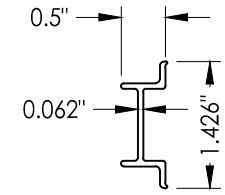

**28 MALE YOKE**

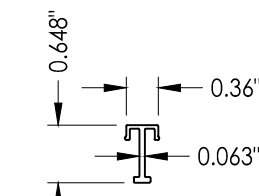

**10 SILL FILLER**

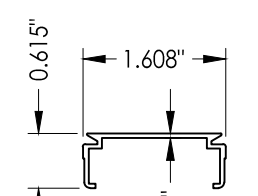

**11 JAMB FILLER**

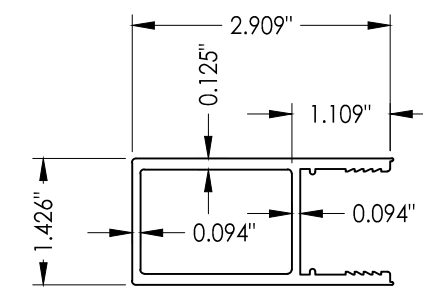

**23 NARROW LOCK STILE/ WIDE FIXED STILE**

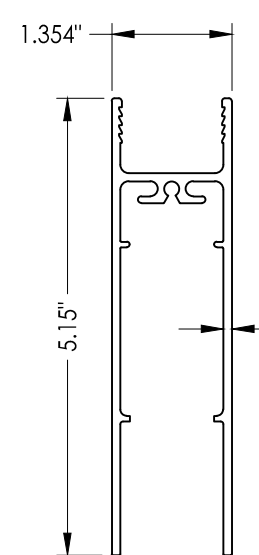

**21 BOTTOM RAIL**

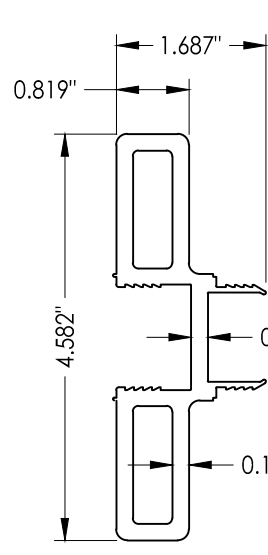

**30 HP ADAPTOR**

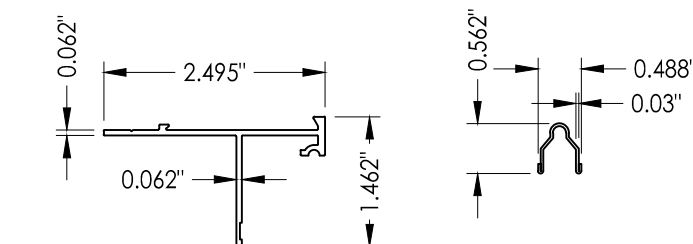

**47 POST INTERLOCKER NAIL-FIN**

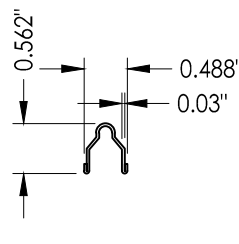

**13 TRACK**

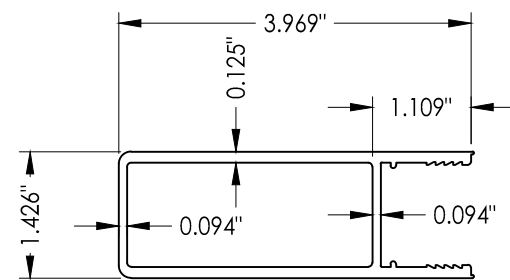

**22 LOCK STYLE**

	Report #:	E8384-301-44
	Date:	04/01/16
	Verified by:	<i>[Signature]</i>

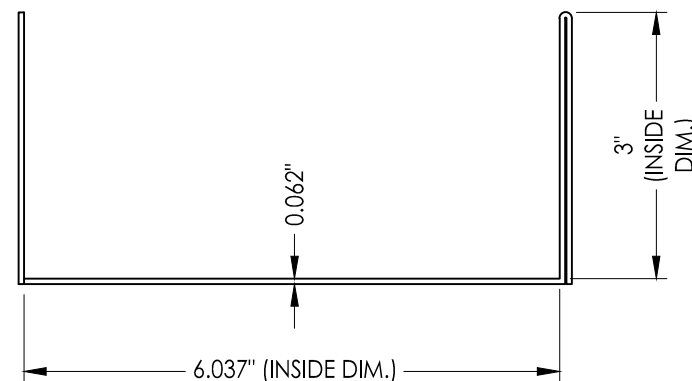

**15 SILLPAN - 3 TRACK**  
(Pocket)

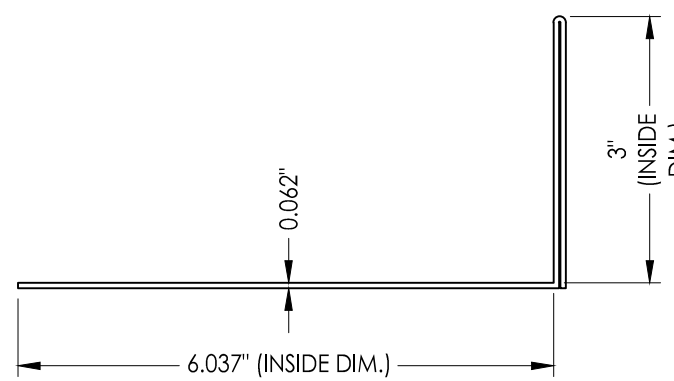

**14 SILLPAN - 3 TRACK**

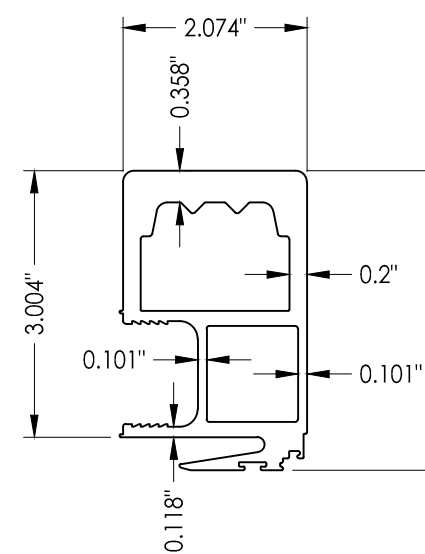

**26 HP INTERLOCKER**

REVISIONS	DATE	DRAWN BY	COMMENTS

MATERIAL:	SERIES 3070-HI
CUSTOMER:	FLEETWOOD WINDOWS AND DOORS
JOB NAME:	FLEETWOOD TAS & AAMA TEST
DRAWN BY:	BL
DATE:	6/22/15
JOB NUMBER:	385199-V2

<b>FLEETWOOD</b> <b>WINDOWS AND DOORS</b> <small>1 FLEETWOOD WAY CORONA, CALIFORNIA 92709 - www.fleetwoodusa.com</small>	
SCALE	↓
DO NOT SCALE	↓
DRAWING NO. :	#
SHEET :	#
11	OF 12

BILL OF MATERIALS			
ITEM #	DESCRIPTION	PART#	MATERIAL
B	2X BUCK SG >= 0.55	N/A	WOOD
C	1/4" MAX. SHIM SPACE	N/A	-
D	#10 x 2-1/2" PFH WOOD SCREW	N/A	STEEL
F	#10 x 2" PPH WOOD SCREW	N/A	STEEL
G	#8 x 1-1/2" PFH WOOD SCREW	N/A	STEEL
H	#8 x 3/4" PPH SMS	N/A	STEEL
1	M/S HEAD (3 TRACK)	3703	6063-T6 ALUM
2	M/S HEAD (2 TRACK)	3702	6063-T6 ALUM
3	M/S HEAD (SINGLE TRACK)	3046	6063-T6 ALUM
4	M/S SILL (3 TRACK)	3743	6063-T6 ALUM
5	M/S SILL (2 TRACK)	3742	6063-T6 ALUM
6	M/S SILL (SINGLE TRACK)	3741	6063-T6 ALUM
7	JAMB (2 TRACK)	3712	6063-T6 ALUM
8	JAMB (1 TRACK)	3048	6063-T6 ALUM
9	HEAD FILLER	3014	STAINLESS STEEL
10	SILL FILLER	3747	STAINLESS STEEL
11	JAMB FILLER	3710	STAINLESS STEEL
12	J-POST INTERLOCKER SNAP-IN	3755	STAINLESS STEEL
13	S.S. TRACK	FW1020	-
14	SILL PAN (3-TRACK)	3720-3	-
15	SILL PAN (3-TRACK)(POCKET)	3720-3	-
16	SMALL FIN SEAL .230	19118	6063-T6 ALUM
17	9/16" GLAZING VINYL (ASTM C864)	25033	6063-T6 ALUM
18	LARGE FIN SEAL .290	19117	6063-T6 ALUM
19	Q-LON (U5212)	19120	6063-T6 ALUM
20	TOP RAIL	3004	6063-T6 ALUM
21	BOTTOM RAIL	3027	6063-T6 ALUM
22	LOCK STILE	3767	6063-T6 ALUM
23	NARROW LOCK STILE/WIDE FIXED STILE	3005	6061-T6 ALUM
24	90° MEETING STILE	3771	6061-T6 ALUM
25	2-1/2" POCKET SIGHTLINE INTERLOCKER	3704	6061-T6 ALUM
26	HP INTERLOCKER	3034	6061-T6 ALUM
27	FEMALE YOKE	3040	6061-T6 ALUM
28	MALE YOKE	3039	6061-T6 ALUM
29	WINDLOAD ADAPTOR	3715	6061-T6 ALUM
30	HP ADAPTOR	3716	STAINLESS STEEL
31	1" X 1" SOLID ALUMINUM	N/A	6061-T6 ALUM
32	1" X 1.25" SOLID ALUMINUM	N/A	6061-T6 ALUM
33	135° SOLID YOKE BLOCK (ALUMINUM)	N/A	6061-T6 ALUM
36	.25" X .75" SOLID ALUMINUM	N/A	6061-T6 ALUM
37	.75" X 1.25" SOLID ALUMINUM	N/A	6061-T6 ALUM
38	AIR BARRIER (SILL)	25383	-
39	AIR BARRIER (HEAD)	24097	-
40	6" AIR BARRIER FOR HP INTERLOCKER	25562	-
41	STRIKE PLATE	24980	STEEL
42	BACK UP PLATE	24981	STEEL
43	10-32 X .5" FHP	N/A	STEEL
44	#10 X 1" PHP	N/A	STEEL
45	#8 TEK X 1/2"	N/A	STEEL
46	DOW 995 SILICONE	N/A	-
47	POST INTERLOCKER NAIL-FIN	3756	6061-T6 ALUM
48	FLUSH PULL	-	S.S.
49	ARCHETYPE NARROW LOCK	-	-
50	ARCHETYPE LOCK	-	-
51	ARCHETYPE ROLLERS	-	-

 Report #: E8384-301-44  
 Date: 04/01/16  
 Verified by: *[Signature]*

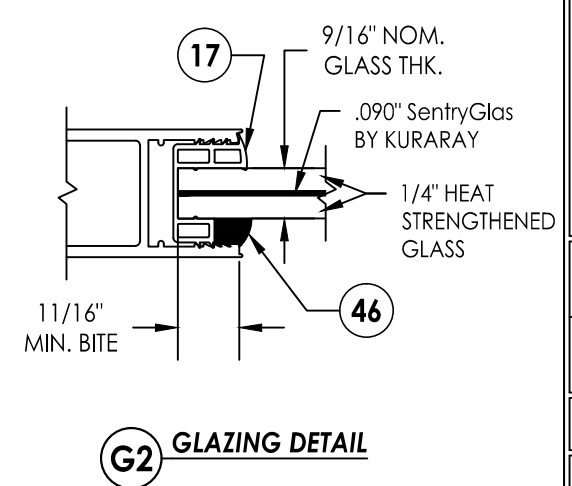
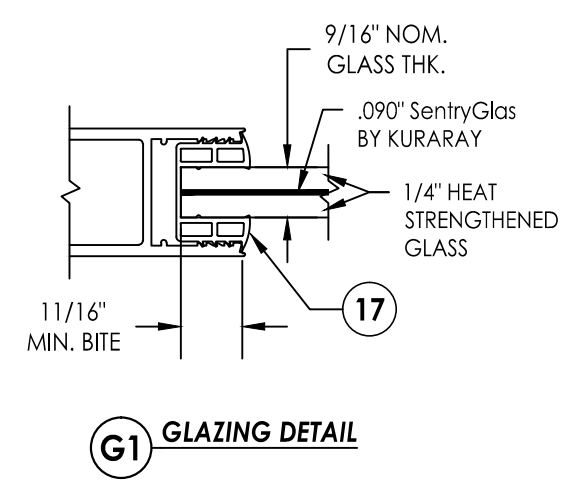
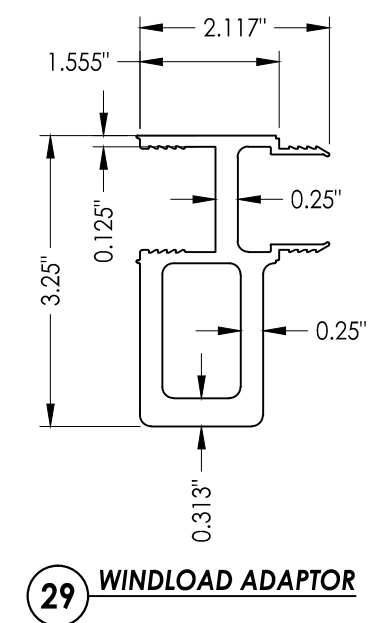
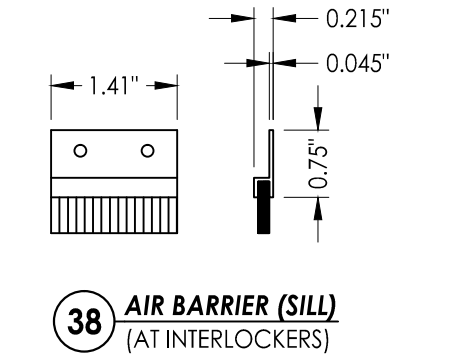
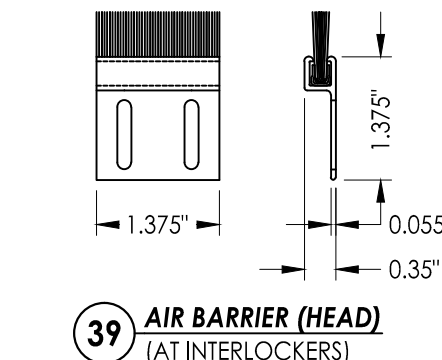
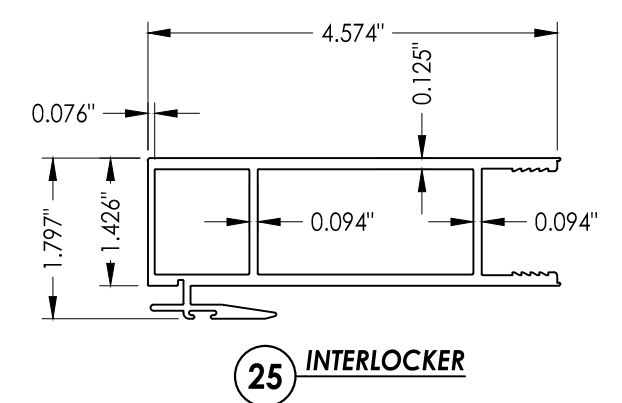
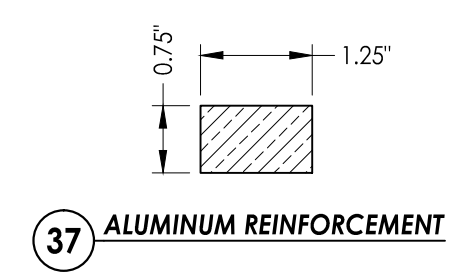
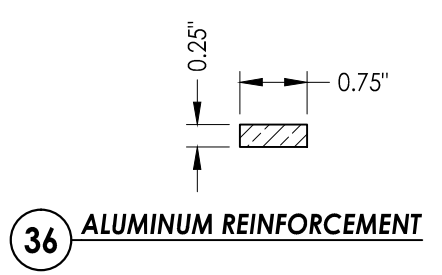
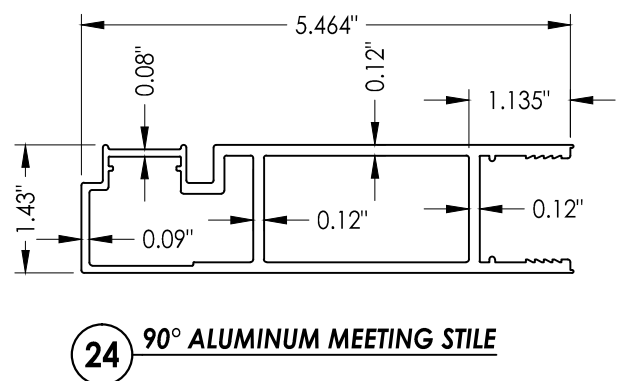
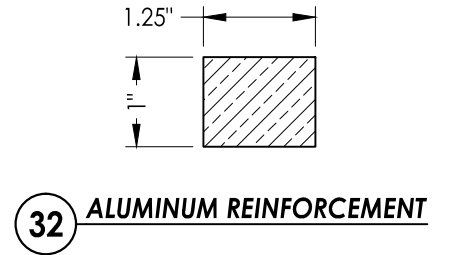
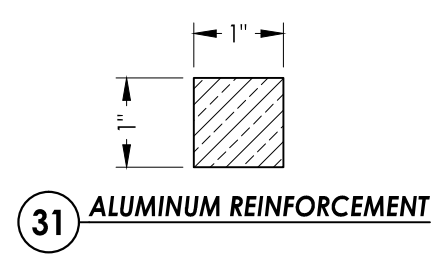
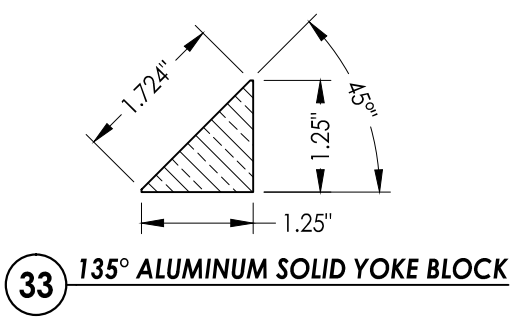

COMMENTS: \_\_\_\_\_  
 DRAWN BY: \_\_\_\_\_  
 DATE: \_\_\_\_\_  
 REVISIONS: \_\_\_\_\_  
 DATE: 6/22/15  
 DRAWN BY: BL  
 JOB NUMBER: 385199-V2  
 MATERIAL: SERIES 3070-HI  
 CUSTOMER: FLEETWOOD WINDOWS AND DOORS  
 JOB NAME: FLEETWOOD TAS & AAMA TEST  
**FLEETWOOD WINDOWS AND DOORS**  
 1 FLEETWOOD WAY CORONA, CALIFORNIA 92709 - www.fleetwoodusa.com  
 SCALE: DO NOT SCALE  
 DRAWING NO.: #  
 SHEET: 12 OF 12