



# Testing Evaluation Laboratories, Inc.

2002 Wood Court Suite 1 – Plant City, FL 33563  
Phone: 813-754-9887

## TEST RESULTS

Dade Lab Certification Number: 11-1213.01  
Test Notification Number: TEL 13-005

Report No: TEL 01990816  
Test Dates: September 23-27, 2013  
Report Date: October 31, 2013

### Issued to:

Fleetwood Windows and Doors  
1 Fleetwood Way  
Corona, CA 92879

**Project Summary:** Testing Evaluation Laboratories, Inc. (TEL) was contracted by Fleetwood Windows and Doors to perform tests on the Kona 3800 Casement and Awning Windows at TEL's Plant City, FL test facility.

Test specimen descriptions and results are reported herein.

**Test Specifications:** The test specimens were evaluated in accordance with the following:

*High Velocity Hurricane Zone Protocols TAS 202-94, TAS 201-94 and TAS 203-94*

### Test Specimen Description:

<b>Series / Model:</b>	Kona 3800 Casement and Awning Windows
<b>Type:</b>	Aluminum Casement and Awning Windows
<b>Overall Size:</b>	42.00" x 84.00" – Specimens 1, 1a, 1b, 1c, 1e, 2,2a, 5, 5a, 6 and 6a – (X) 42.00" x 65.00" – Specimens 3 and 3a – (X) 125.00" x 84.00" – Specimen 4 – (XXX) 42.00" x 180.00" – Specimen 7 - (X/O/X) 42.00" x 180.00" – Specimens 8 and 8a - (O/X/O) 42.00" x 72.00" – Specimens 12 and 12a – (X)
<b>Daylight Opening:</b>	33.063"x 75.13" – Specimens 1, 1a, 1b, 1c, 1e, 2,2a, 5, 5a, 6 and 6a – (X) 33.625" x 56.50" – Specimens 3 and 3a – (X) 38.88" x 75.06" – Specimen 4 – (XXX) – All Panels 33.13" x 37.875" – Specimen 7 - Top Active Panel (X) 39.062" x 81.625" – Specimen 7 - Center Fixed Panel (O) 33.13" x 41.375" – Specimen 7 - Bottom Active Panel (X)

**Test Specimen Description: Continued**

**Daylight Opening:** 39.062" x 9.312" – Specimens 8 and 8a - Top Fixed Panel (O)  
33.13" x 76.062" – Specimens 8 and 8a - Center Active Panel (X)  
39.062" x 81.625" – Specimens 8 and 8a - Bottom Fixed Panel (O)  
32.88" x 56.06" – Specimens 12 and 12a – (X)

**Glazing Detail:** See attached drawing numbers L-7031, L-7032, L-7032A and L-7033  
For glazing details.

**Frame Material:** Aluminum

**Finish:** Mill Finish

**For Tested Elevation, Vertical Cross Sections, Horizontal Cross Sections, Components, Frame Anchoring, Glazing Detail and Bill of Materials See Attached Drawing numbers L-7031, L-7032, L-7032A and L-7033.**

**SEQUENCE OF TESTS PERFORMED:**

**STRUCTURAL TESTS (TAS 202)**

**Specimen 1 – 42.0” x 84.0” Aluminum Casement Window (X) – Tested with (4) Hinges**

**Design Pressure                      Positive 65.0      Negative 65.0**

Air Infiltration (ASTM E283-04)	Pressure	SCFM/Ft <sup>2</sup>	Result
	1.57 PSF	0.065	Pass
Air Infiltration (ASTM E283-04)	Pressure	SCFM/Ft <sup>2</sup>	Result
	6.24 PSF	0.158	Pass

**Structural Loads (ASTM E330-02)**

Range	Time (sec)	Load (psf)
Half Test Positive	30	32.50
Design Positive	30	65.00
Half Test Negative	30	32.50
Design Negative	30	65.00

Water Infiltration (ASTM E331-00)	Pressure	Time	Result
	9.75 PSF	15.0 Min.	Pass

**Note #1: Water Infiltration performed after Positive and Negative half and design loads.**

**Structural Loads (ASTM E330-02)**

Range	Time (sec)	Load (psf)	Location	Deflection	Set	Allowable (Set)
Half Proof Positive	10	48.75				
Test Positive	30	97.50	1	0.032"	0.010"	0.150"
Half Proof Negative	10	48.75				
Test Negative	30	97.50	1	0.033"	0.004"	0.150"

**Deflection Locations:**

**Location 1 – Center of Top Rail**

**Forced Entry**                      Passed – No Entry

**Conclusion:** TEL observed no signs of failure in any area of this test specimen during the Uniform Static Load Test. In addition, specimen met the permanent set requirements. Therefore, this specimen satisfies the uniform static load test requirements of TAS 202-94.

James Hayhurst, Test Technicians

**SEQUENCE OF TESTS PERFORMED:**

**STRUCTURAL TESTS (TAS 202)**

**Specimen 1 (e) – 42.0" x 84.0" Aluminum Casement Window (X) – Tested with (5) Hinges**

**Design Pressure                  Positive 65.0    Negative 85.0**

**Structural Loads (ASTM E330-02)**

<b>Range</b>	<b>Time (sec)</b>	<b>Load (psf)</b>
Half Test Positive	30	32.50
Design Positive	30	65.00
Half Test Negative	30	42.50
Design Negative	30	85.00

**Structural Loads (ASTM E330-02)**

<b>Range</b>	<b>Time (sec)</b>	<b>Load (psf)</b>	<b>Location</b>	<b>Deflection</b>	<b>Set</b>	<b>Allowable (Set)</b>
Half Proof Positive	10	48.75				
Test Positive	30	97.50	1	0.036"	0.011"	0.150"
Half Proof Negative	10	63.75				
Test Negative	30	127.50	1	0.095"	0.002"	0.150"

***Deflection Locations:***

***Location 1 – Center of Top Rail***

**Conclusion:** TEL observed no signs of failure in any area of this test specimen during the Uniform Static Load Test. In addition, specimen met the permanent set requirements. Therefore, this specimen satisfies the uniform static load test requirements of TAS 202-94.

James Hayhurst, Test Technicians

**SEQUENCE OF TESTS PERFORMED:**

**STRUCTURAL TESTS (TAS 202)**

**Specimen 2 – 42.0" x 84.0" Aluminum Casement Window (X)**

**Design Pressure                  Positive 65.0    Negative 85.0**

**Structural Loads (ASTM E330-02)**

<b>Range</b>	<b>Time (sec)</b>	<b>Load (psf)</b>
Half Test Positive	30	32.50
Design Positive	30	65.00
Half Test Negative	30	42.50
Design Negative	30	85.00

**Structural Loads (ASTM E330-02)**

<b>Range</b>	<b>Time (sec)</b>	<b>Load (psf)</b>	<b>Location</b>	<b>Deflection</b>	<b>Set</b>	<b>Allowable (Set)</b>
Half Proof Positive	10	48.75				
Test Positive	30	97.50	1	0.037"	0.002"	0.150"
Half Proof Negative	10	63.75				
Test Negative	30	127.50	1	0.063"	0.009"	0.150"

***Deflection Locations:***

***Location 1 – Center of Top Rail***

**Conclusion:** TEL observed no signs of failure in any area of this test specimen during the Uniform Static Load Test. In addition, specimen met the permanent set requirements. Therefore, this specimen satisfies the uniform static load test requirements of TAS 202-94.

James Hayhurst, Test Technicians

**SEQUENCE OF TESTS PERFORMED:**

**STRUCTURAL TESTS (TAS 202)**

**Specimen 3 – 42.0" x 65.0" Aluminum Casement Window (X)**

**Design Pressure                  Positive 65.0      Negative 85.0**

**Structural Loads (ASTM E330-02)**

<b>Range</b>	<b>Time (sec)</b>	<b>Load (psf)</b>
Half Test Positive	30	32.50
Design Positive	30	65.00
Half Test Negative	30	42.50
Design Negative	30	85.00

**Structural Loads (ASTM E330-02)**

<b>Range</b>	<b>Time (sec)</b>	<b>Load (psf)</b>	<b>Location</b>	<b>Deflection</b>	<b>Set</b>	<b>Allowable (Set)</b>
Half Proof Positive	10	48.75				
Test Positive	30	97.50	1	0.019"	0.005"	0.150"
Half Proof Negative	10	63.75				
Test Negative	30	127.50	1	0.027"	0.008"	0.150"

***Deflection Locations:***

***Location 1 – Center of Top Rail***

**Conclusion:** TEL observed no signs of failure in any area of this test specimen during the Uniform Static Load Test. In addition, specimen met the permanent set requirements. Therefore, this specimen satisfies the uniform static load test requirements of TAS 202-94.

James Hayhurst, Test Technicians

**STRUCTURAL TESTS (TAS 202)**

**Specimen 4 – 125.0” x 84.0” Muller Aluminum Casement Windows (XXX)**

**Design Pressure                      Positive 65.0      Negative 65.0**

Air Infiltration (ASTM E283-04)	Pressure	SCFM/Ft <sup>2</sup>	Result
	1.57 PSF	0.018	Pass
Air Infiltration (ASTM E283-04)	Pressure	SCFM/Ft <sup>2</sup>	Result
	6.24 PSF	0.035	Pass

**Structural Loads (ASTM E330-02)**

Range	Time (sec)	Load (psf)	Location	Deflection	Allowable (Def)
Half Test Positive	30	32.50			
Design Positive	30	65.00	1	0.175"	0.450"
Half Test Negative	30	32.50			
Design Negative	30	65.00	1	0.206"	0.450"

Water Infiltration (ASTM E331-00)	Pressure	Time	Result
	9.75 PSF	15.0 Min.	Pass

**Note #1: Water Infiltration performed after Positive and Negative half and design loads.**

**Structural Loads (ASTM E330-02)**

Range	Time (sec)	Load (psf)	Location	Deflection	Set	Allowable (Set)
Half Proof Positive	10	48.75				
Test Positive	30	97.50	1	0.343"	0.005"	0.324"
Half Proof Negative	10	48.75				
Test Negative	30	97.50	1	0.278"	0.016"	0.324"

**Deflection Locations:**

**Location 1 – Center of Mullion**

**Forced Entry**                      Passed – No Entry

**Conclusion:** TEL observed no signs of failure in any area of this test specimen during the Uniform Static Load Test. In addition, specimen met the permanent set requirements. Therefore, this specimen satisfies the uniform static load test requirements of TAS 202-94.

James Hayhurst, Test Technicians

**SEQUENCE OF TESTS PERFORMED:**

**STRUCTURAL TESTS (TAS 202)**

**Specimen 5 – 42.0” x 84.0” Aluminum Casement Window (X)**

**Design Pressure                  Positive 65.0      Negative 65.0**

**Structural Loads (ASTM E330-02)**

<b>Range</b>	<b>Time (sec)</b>	<b>Load (psf)</b>
Half Test Positive	30	32.50
Design Positive	30	65.00
Half Test Negative	30	32.50
Design Negative	30	65.00

**Structural Loads (ASTM E330-02)**

<b>Range</b>	<b>Time (sec)</b>	<b>Load (psf)</b>	<b>Location</b>	<b>Deflection</b>	<b>Set</b>	<b>Allowable (Set)</b>
Half Proof Positive	10	48.75				
Test Positive	30	97.50	1	0.012"	0.004"	0.150"
Half Proof Negative	10	48.75				
Test Negative	30	97.50	1	0.018"	0.001"	0.150"

***Deflection Locations:***

***Location 1 – Center of Top Rail***

**Conclusion:** TEL observed no signs of failure in any area of this test specimen during the Uniform Static Load Test. In addition, specimen met the permanent set requirements. Therefore, this specimen satisfies the uniform static load test requirements of TAS 202-94.

James Hayhurst, Test Technicians

**SEQUENCE OF TESTS PERFORMED:**

**STRUCTURAL TESTS (TAS 202)**

**Specimen 6 – 42.0” x 84.0” Aluminum Casement Window (X)**

**Design Pressure                  Positive 65.0    Negative 65.0**

**Structural Loads (ASTM E330-02)**

<b>Range</b>	<b>Time (sec)</b>	<b>Load (psf)</b>
Half Test Positive	30	32.50
Design Positive	30	65.00
Half Test Negative	30	32.50
Design Negative	30	65.00

**Structural Loads (ASTM E330-02)**

<b>Range</b>	<b>Time (sec)</b>	<b>Load (psf)</b>	<b>Location</b>	<b>Deflection</b>	<b>Set</b>	<b>Allowable (Set)</b>
Half Proof Positive	10	48.75				
Test Positive	30	97.50	1	0.032"	0.001"	0.150"
Half Proof Negative	10	48.75				
Test Negative	30	97.50	1	0.066"	0.012"	0.150"

***Deflection Locations:***

***Location 1 – Center of Top Rail***

**Conclusion:** TEL observed no signs of failure in any area of this test specimen during the Uniform Static Load Test. In addition, specimen met the permanent set requirements. Therefore, this specimen satisfies the uniform static load test requirements of TAS 202-94.

James Hayhurst, Test Technicians

**SEQUENCE OF TESTS PERFORMED:**

**STRUCTURAL TESTS (TAS 202)**

**Specimen 7 – 42.0" x 180.0" Stacked Aluminum Awning/Fixed/Awning Window (X/O/X)**

Design Pressure	Positive 65.0	Negative 65.0		
Air Infiltration (ASTM E283-04)	Pressure 1.57 PSF	SCFM/Ft <sup>2</sup> 0.0249	Result Pass	
Air Infiltration (ASTM E283-04)	Pressure 6.24 PSF	SCFM/Ft <sup>2</sup> 0.149	Result Pass	

**Structural Loads (ASTM E330-02)**

Range	Time (sec)	Load (psf)	Location	Deflection	Allowable (Def)
Half Test Positive	30	32.50			
Design Positive	30	65.00	1	0.012"	0.233"
Half Test Negative	30	32.50			
Design Negative	30	65.00	1	0.014"	0.233"

Water Infiltration (ASTM E331-00)	Pressure 9.75 PSF	Time 15.0 Min.	Result Pass
-----------------------------------	----------------------	-------------------	----------------

**Note #1: Water Infiltration performed after Positive and Negative half and design loads.**

**Structural Loads (ASTM E330-02)**

Range	Time (sec)	Load (psf)	Location	Deflection	Set	Allowable (Set)
Half Proof Positive	10	48.75				
Test Positive	30	97.50	1	0.021"	0.004"	0.168"
			2	0.011"	0.006"	0.018"
Half Proof Negative	10	48.75				
Test Negative	30	97.50	1	0.034"	0.015"	0.168"
			2	0.019"	0.007"	0.018"

**Deflection Locations:**

**Location 1 – Center of Mullion**  
**Location 2 – Between Anchors on Fixed Unit**

**Forced Entry** Passed – No Entry

**Conclusion:** TEL observed no signs of failure in any area of this test specimen during the Uniform Static Load Test. In addition, specimen met the permanent set requirements. Therefore, this specimen satisfies the uniform static load test requirements of TAS 202-94.

James Hayhurst, Test Technicians

**SEQUENCE OF TESTS PERFORMED:**

**STRUCTURAL TESTS (TAS 202)**

**Specimen 8 – 42.0" x 180.0" Stacked Aluminum Fixed/Awning/Fixed Window (O/X/O)**

**Design Pressure                      Positive 65.0      Negative 65.0**

Air Infiltration (ASTM E283-04)	Pressure 1.57 PSF	SCFM/Ft <sup>2</sup> 0.021	Result Pass
Air Infiltration (ASTM E283-04)	Pressure 6.24 PSF	SCFM/Ft <sup>2</sup> 0.019	Result Pass

**Structural Loads (ASTM E330-02)**

<b>Range</b>	<b>Time (sec)</b>	<b>Load (psf)</b>	<b>Location</b>	<b>Deflection</b>	<b>Allowable (Def)</b>
Half Test Positive	30	32.50			
Design Positive	30	65.00	1	0.005"	0.233"
Half Test Negative	30	32.50			
Design Negative	30	65.00	1	0.007"	0.233"

Water Infiltration (ASTM E331-00)	Pressure 9.75 PSF	Time 15.0 Min.	Result Pass
-----------------------------------	----------------------	-------------------	----------------

**Note #1: Water Infiltration performed after Positive and Negative half and design loads.**

**Structural Loads (ASTM E330-02)**

<b>Range</b>	<b>Time (sec)</b>	<b>Load (psf)</b>	<b>Location</b>	<b>Deflection</b>	<b>Set</b>	<b>Allowable (Set)</b>
Half Proof Positive	10	48.75				
Test Positive	30	97.50	1	0.020"	0.002"	0.168"
			2	0.018"	0.006"	0.028"
Half Proof Negative	10	48.75				
Test Negative	30	97.50	1	0.044"	0.011"	0.168"
			2	0.015"	0.004"	0.028"

**Deflection Locations:**

- Location 1 – Center of Mullion**
- Location 2 – Between Anchors on Fixed Unit**

**Forced Entry**                      Passed – No Entry

**Conclusion:** TEL observed no signs of failure in any area of this test specimen during the Uniform Static Load Test. In addition, specimen met the permanent set requirements. Therefore, this specimen satisfies the uniform static load test requirements of TAS 202-94.  
James Hayhurst, Test Technicians

**SEQUENCE OF TESTS PERFORMED:**

**STRUCTURAL TESTS (TAS 202)**

**Specimen 12 – 42.0” x 72.0” Aluminum Casement Window (X)**

**Design Pressure                  Positive 65.0    Negative 65.0**

**Structural Loads (ASTM E330-02)**

<b>Range</b>	<b>Time (sec)</b>	<b>Load (psf)</b>
Half Test Positive	30	32.50
Design Positive	30	65.00
Half Test Negative	30	32.50
Design Negative	30	65.00

**Structural Loads (ASTM E330-02)**

<b>Range</b>	<b>Time (sec)</b>	<b>Load (psf)</b>	<b>Location</b>	<b>Deflection</b>	<b>Set</b>	<b>Allowable (Set)</b>
Half Proof Positive	10	48.75				
Test Positive	30	97.50	1	0.079"	0.049"	0.150"
Half Proof Negative	10	48.75				
Test Negative	30	97.50	1	0.112"	0.063"	0.150"

***Deflection Locations:***

***Location 1 – Center of Top Rail***

**Conclusion:** TEL observed no signs of failure in any area of this test specimen during the Uniform Static Load Test. In addition, specimen met the permanent set requirements. Therefore, this specimen satisfies the uniform static load test requirements of TAS 202-94.

James Hayhurst, Test Technicians

## IMPACT AND CYCLING TESTS (TAS 201/203)

### Specimen 1A – 42.0” x 84.0” Aluminum Casement Window – (X)

#### TAS 201 and 203 – Large Missile Impact (2 x 4 Southern Yellow Pine)

Cond. Temp Of Specimen	Missile Level	Missile Weight	Missile Length	Muzzle Distance From Specimen
77°F	D	9.0 lbs, 2 oz	8'-1/4"	17'1"

Impact Location	Results	X - Measurement	Y - Measurement	Speed
1	Pass	21.0"	42.0"	49.9 fps
2	Pass	31.0"	11.0"	49.7 fps
Orientation of Missile at Impact was within +/-5° of horizontal. None of the impacts penetrated the specimens. "X" measurement is from the left edge of test specimen. "Y" measurement is from the bottom edge of test specimen.				

#### TAS 201 and 203– Fatigue Load Cycling      Design Pressure +65.0 psf / -65.0 psf

Positive % of Test Load	Positive Pressure Range (psf)	Number Of Cycles	Average Cycle Time (Sec)
20% to 50%	13.0 to 32.5	3500	2.54
0% to 60%	0.0 to 39.0	300	2.49
50% to 80%	32.5 to 52.0	600	1.69
30% to 100%*	19.5 to 65.0	100	2.98

Negative % of Test Load	Negative Pressure Range (psf)	Number Of Cycles	Average Cycle Time (Sec)
30% to 100%*	19.5 to 65.0	50	2.87
50% to 80%	32.5 to 52.0	1050	1.54
0% to 60%	0.0 to 39.0	50	2.51
20% to 50%	13.0 to 32.5	3350	2.62

\*Panel deflected 2.50" from original plane at 100% Positive load and 2.38" from original plane at 100% Negative load. At the completion of cycles the door panel was operable. There were no tears in the film. In our opinion, the tape and film used to seal for air leakage did not influence the results of the test.

Jarrett Wright and James Hayhurst, Test Technicians

Mfg Observers – Joe Zammit

## IMPACT AND CYCLING TESTS (TAS 201/203)

### Specimen 1B – 42.0” x 84.0” Aluminum Casement Window – (X)

#### TAS 201 and 203 – Large Missile Impact (2 x 4 Southern Yellow Pine)

Cond. Temp Of Specimen	Missile Level	Missile Weight	Missile Length	Muzzle Distance From Specimen
77°F	D	9.0 lbs, 2 oz	8'-1/4"	17'1"

Impact Location	Results	X - Measurement	Y - Measurement	Speed
1	Pass	20.75"	42.25"	49.9 fps
2	Pass	30.75"	10.75"	49.9 fps
Orientation of Missile at Impact was within +/-5° of horizontal. None of the impacts penetrated the specimens. "X" measurement is from the left edge of test specimen. "Y" measurement is from the bottom edge of test specimen.				

#### TAS 201 and 203– Fatigue Load Cycling Design Pressure +65.0 psf / -65.0 psf

Positive % of Test Load	Positive Pressure Range (psf)	Number Of Cycles	Average Cycle Time (Sec)
20% to 50%	13.0 to 32.5	3500	2.13
0% to 60%	0.0 to 39.0	300	2.83
50% to 80%	32.5 to 52.0	600	1.58
30% to 100%*	19.5 to 65.0	100	2.00

Negative % of Test Load	Negative Pressure Range (psf)	Number Of Cycles	Average Cycle Time (Sec)
30% to 100%*	19.5 to 65.0	50	2.29
50% to 80%	32.5 to 52.0	1050	1.58
0% to 60%	0.0 to 39.0	50	1.79
20% to 50%	13.0 to 32.5	3350	1.73
*Panel deflected 2.38" from original plane at 100% Positive load and 2.75" from original plane at 100% Negative load. At the completion of cycles the door panel was operable. There were no tears in the film. In our opinion, the tape and film used to seal for air leakage did not influence the results of the test.			

Jarrett Wright and James Hayhurst, Test Technicians

Mfg Observers – Joe Zammit

## IMPACT AND CYCLING TESTS (TAS 201/203)

### Specimen 1C – 42.0” x 84.0” Aluminum Casement Window – (X)

#### TAS 201 and 203 – Large Missile Impact (2 x 4 Southern Yellow Pine)

Cond. Temp Of Specimen	Missile Level	Missile Weight	Missile Length	Muzzle Distance From Specimen
77°F	D	9.0 lbs, 2 oz	8'-1/4"	17'1"

Impact Location	Results	X - Measurement	Y - Measurement	Speed
1	Pass	21.25"	41.75"	49.9 fps
2	Pass	10.50"	75.00"	50.0 fps
Orientation of Missile at Impact was within +/-5° of horizontal. None of the impacts penetrated the specimens. "X" measurement is from the left edge of test specimen. "Y" measurement is from the bottom edge of test specimen.				

#### TAS 201 and 203– Fatigue Load Cycling Design Pressure +65.0 psf / -65.0 psf

Positive % of Test Load	Positive Pressure Range (psf)	Number Of Cycles	Average Cycle Time (Sec)
20% to 50%	13.0 to 32.5	3500	2.79
0% to 60%	0.0 to 39.0	300	2.62
50% to 80%	32.5 to 52.0	600	1.70
30% to 100%*	19.5 to 65.0	100	2.95

Negative % of Test Load	Negative Pressure Range (psf)	Number Of Cycles	Average Cycle Time (Sec)
30% to 100%*	19.5 to 65.0	50	2.94
50% to 80%	32.5 to 52.0	1050	1.60
0% to 60%	0.0 to 39.0	50	2.71
20% to 50%	13.0 to 32.5	3350	1.82
*Panel deflected 2.25" from original plane at 100% Positive load and 2.00" from original plane at 100% Negative load. At the completion of cycles the door panel was operable. There were no tears in the film. In our opinion, the tape and film used to seal for air leakage did not influence the results of the test.			

Jarrett Wright and James Hayhurst, Test Technicians

Mfg Observers – Joe Zammit

# IMPACT AND CYCLING TESTS (TAS 201/203)

## Specimen 2A – 42.0” x 84.0” Aluminum Casement Window with Nail Fin – (X)

### TAS 201 and 203 – Large Missile Impact (2 x 4 Southern Yellow Pine)

Cond. Temp Of Specimen	Missile Level	Missile Weight	Missile Length	Muzzle Distance From Specimen
77°F	D	9.0 lbs, 2 oz	8'-1/4"	17'1"

Impact Location	Results	X - Measurement	Y - Measurement	Speed
1	Pass	22.00"	43.00"	50.1 fps
2	Pass	32.50"	11.25"	50.0 fps
Orientation of Missile at Impact was within +/-5° of horizontal. None of the impacts penetrated the specimens. "X" measurement is from the left edge of test specimen. "Y" measurement is from the bottom edge of test specimen.				

### TAS 201 and 203– Fatigue Load Cycling      Design Pressure +65.0 psf / -70.0 psf

Positive % of Test Load	Positive Pressure Range (psf)	Number Of Cycles	Average Cycle Time (Sec)
20% to 50%	13.0 to 32.5	3500	2.31
0% to 60%	0.0 to 39.0	300	2.51
50% to 80%	32.5 to 52.0	600	1.98
30% to 100%*	19.5 to 65.0	100	2.88

Negative % of Test Load	Negative Pressure Range (psf)	Number Of Cycles	Average Cycle Time (Sec)
30% to 100%*	21.0 to 70.0	50	2.91
50% to 80%	35.0 to 55.0	1050	2.03
0% to 60%	0.0 to 42.0	50	2.32
20% to 50%	14.0 to 35.0	3350	1.82
*Panel deflected 1.75" from original plane at 100% Positive load and 1.88" from original plane at 100% Negative load. At the completion of cycles the door panel was operable. There were no tears in the film. In our opinion, the tape and film used to seal for air leakage did not influence the results of the test.			

Jarrett Wright and James Hayhurst, Test Technicians

Mfg Observers – Joe Zammit

## IMPACT AND CYCLING TESTS (TAS 201/203)

### Specimen 3A – 42.0" x 65.0" Aluminum Casement Window – (X)

#### TAS 201 and 203 – Large Missile Impact (2 x 4 Southern Yellow Pine)

Cond. Temp Of Specimen	Missile Level	Missile Weight	Missile Length	Muzzle Distance From Specimen
76°F	D	9.0 lbs, 3 oz	8'-0"	17'0"

Impact Location	Results	X - Measurement	Y - Measurement	Speed
1	Pass	21.00"	33.00"	49.8 fps
2	Pass	11.00"	11.00"	49.9 fps
Orientation of Missile at Impact was within +/-5° of horizontal. None of the impacts penetrated the specimens. "X" measurement is from the left edge of test specimen. "Y" measurement is from the bottom edge of test specimen.				

#### TAS 201 and 203– Fatigue Load Cycling      Design Pressure +65.0 psf / -65.0 psf

Positive % of Test Load	Positive Pressure Range (psf)	Number Of Cycles	Average Cycle Time (Sec)
20% to 50%	13.0 to 32.5	3500	1.50
0% to 60%	0.0 to 39.0	300	2.25
50% to 80%	32.5 to 52.0	600	1.25
30% to 100%*	19.5 to 65.0	100	2.07

Negative % of Test Load	Negative Pressure Range (psf)	Number Of Cycles	Average Cycle Time (Sec)
30% to 100%*	19.5 to 65.0	50	2.27
50% to 80%	32.5 to 52.0	1050	1.63
0% to 60%	0.0 to 39.0	50	1.70
20% to 50%	13.0 to 32.5	3350	1.36
*Panel deflected 1.75" from original plane at 100% Positive load and 2.00" from original plane at 100% Negative load. At the completion of cycles the door panel was operable. There were no tears in the film. In our opinion, the tape and film used to seal for air leakage did not influence the results of the test.			

Jarrett Wright and James Hayhurst, Test Technicians

Mfg Observers – Joe Zammit

## IMPACT AND CYCLING TESTS (TAS 201/203)

Specimen 5A – 42.0" x 84.0" Aluminum Casement Window with Nail Fin – (X)

### TAS 201 and 203 – Large Missile Impact (2 x 4 Southern Yellow Pine)

Cond. Temp Of Specimen	Missile Level	Missile Weight	Missile Length	Muzzle Distance From Specimen
76°F	D	9.0 lbs, 2 oz	8'-1/4"	17'1"

Impact Location	Results	X - Measurement	Y - Measurement	Speed
1	Pass	21.00"	42.00"	49.7 fps
2	Pass	11.00"	75.00"	50.0 fps
Orientation of Missile at Impact was within +/-5° of horizontal. None of the impacts penetrated the specimens. "X" measurement is from the left edge of test specimen. "Y" measurement is from the bottom edge of test specimen.				

### TAS 201 and 203– Fatigue Load Cycling Design Pressure +65.0 psf / -65.0 psf

Positive % of Test Load	Positive Pressure Range (psf)	Number Of Cycles	Average Cycle Time (Sec)
20% to 50%	13.0 to 32.5	3500	2.08
0% to 60%	0.0 to 39.0	300	1.83
50% to 80%	32.5 to 52.0	600	1.72
30% to 100%*	19.5 to 65.0	100	2.31

Negative % of Test Load	Negative Pressure Range (psf)	Number Of Cycles	Average Cycle Time (Sec)
30% to 100%*	19.5 to 65.0	50	2.89
50% to 80%	32.5 to 52.0	1050	2.27
0% to 60%	0.0 to 39.0	50	2.68
20% to 50%	13.0 to 32.5	3350	2.00

\*Panel deflected 1.50" from original plane at 100% Positive load and 1.50" from original plane at 100% Negative load. At the completion of cycles the door panel was operable. There were no tears in the film. In our opinion, the tape and film used to seal for air leakage did not influence the results of the test.

Jarrett Wright and James Hayhurst, Test Technicians

Mfg Observers – Joe Zammit

## IMPACT AND CYCLING TESTS (TAS 201/203)

Specimen 6A – 42.0" x 84.0" Aluminum Casement Window –Direct Mount – (X)

### TAS 201 and 203 – Large Missile Impact (2 x 4 Southern Yellow Pine)

Cond. Temp Of Specimen	Missile Level	Missile Weight	Missile Length	Muzzle Distance From Specimen
76°F	D	9.0 lbs, 2 oz	8'-1/4"	17'1"

Impact Location	Results	X - Measurement	Y - Measurement	Speed
1	Pass	20.75"	42.00"	49.9 fps
2	Pass	11.25"	74.75"	50.0 fps
Orientation of Missile at Impact was within +/-5° of horizontal. None of the impacts penetrated the specimens. "X" measurement is from the left edge of test specimen. "Y" measurement is from the bottom edge of test specimen.				

### TAS 201 and 203– Fatigue Load Cycling Design Pressure +65.0 psf / -65.0 psf

Positive % of Test Load	Positive Pressure Range (psf)	Number Of Cycles	Average Cycle Time (Sec)
20% to 50%	13.0 to 32.5	3500	2.41
0% to 60%	0.0 to 39.0	300	2.79
50% to 80%	32.5 to 52.0	600	2.05
30% to 100%*	19.5 to 65.0	100	2.26

Negative % of Test Load	Negative Pressure Range (psf)	Number Of Cycles	Average Cycle Time (Sec)
30% to 100%*	19.5 to 65.0	50	2.95
50% to 80%	32.5 to 52.0	1050	1.55
0% to 60%	0.0 to 39.0	50	2.09
20% to 50%	13.0 to 32.5	3350	1.68
*Panel deflected 2.50" from original plane at 100% Positive load and 2.88" from original plane at 100% Negative load. At the completion of cycles the door panel was operable. There were no tears in the film. In our opinion, the tape and film used to seal for air leakage did not influence the results of the test.			

Jarrett Wright and James Hayhurst, Test Technicians

Mfg Observers – Joe Zammit

## IMPACT AND CYCLING TESTS (TAS 201/203)

Specimen 8A – 42.0" x 180.0" Aluminum Stacked Fixed/Awning/Fixed Window – (O/X/O)

### TAS 201 and 203 – Large Missile Impact (2 x 4 Southern Yellow Pine)

Cond. Temp Of Specimen	Missile Level	Missile Weight	Missile Length	Muzzle Distance From Specimen
76°F	D	9.0 lbs, 3 oz	8'-0"	17'0"

Impact Location	Results	X - Measurement	Y - Measurement	Speed
1	Pass	32.00"	11.00"	49.9 fps
2	Pass	21.00"	43.00"	49.7 fps
3	Pass	21.00"	84.00"	49.9 fps
4	Pass	32.00"	94.00"	50.0 fps
5	Pass	21.00"	126.00"	49.8 fps
<p>Orientation of Missile at Impact was within +/-5° of horizontal.                      None of the impacts penetrated the specimens.                      "X" measurement is from the left edge of test specimen.                      "Y" measurement is from the bottom edge of test specimen.</p>				

### TAS 201 and 203– Fatigue Load Cycling      Design Pressure +65.0 psf / -65.0 psf

Positive % of Test Load	Positive Pressure Range (psf)	Number Of Cycles	Average Cycle Time (Sec)
20% to 50%	13.0 to 32.5	3500	2.93
0% to 60%	0.0 to 39.0	300	2.81
50% to 80%	32.5 to 52.0	600	1.75
30% to 100%*	19.5 to 65.0	100	2.65

Negative % of Test Load	Negative Pressure Range (psf)	Number Of Cycles	Average Cycle Time (Sec)
30% to 100%*	19.5 to 65.0	50	2.81
50% to 80%	32.5 to 52.0	1050	1.65
0% to 60%	0.0 to 39.0	50	2.10
20% to 50%	13.0 to 32.5	3350	2.28
<p>*Panel deflected 2.25" from original plane at 100% Positive load and 2.75" from original plane at 100% Negative load. At the completion of cycles the door panel was operable. There were no tears in the film. In our opinion, the tape and film used to seal for air leakage did not influence the results of the test.</p>			

Jarrett Wright and James Hayhurst, Test Technicians

Mfg Observers – Joe Zammit

## IMPACT AND CYCLING TESTS (TAS 201/203)

Specimen 12A – 42.0” x 72.0” Aluminum Casement Window – (X)

### TAS 201 and 203 – Large Missile Impact (2 x 4 Southern Yellow Pine)

Cond. Temp Of Specimen	Missile Level	Missile Weight	Missile Length	Muzzle Distance From Specimen
76°F	D	9.0 lbs, 2 oz	8'-1/4"	17'1"

Impact Location	Results	X - Measurement	Y - Measurement	Speed
1	Pass	21.00"	36.00"	49.8 fps
2	Pass	9.00"	9.50"	50.1 fps
Orientation of Missile at Impact was within +/-5° of horizontal. None of the impacts penetrated the specimens. "X" measurement is from the left edge of test specimen. "Y" measurement is from the bottom edge of test specimen.				

### TAS 201 and 203– Fatigue Load Cycling      Design Pressure +65.0 psf / -65.0 psf

Positive % of Test Load	Positive Pressure Range (psf)	Number Of Cycles	Average Cycle Time (Sec)
20% to 50%	13.0 to 32.5	3500	2.12
0% to 60%	0.0 to 39.0	300	1.71
50% to 80%	32.5 to 52.0	600	1.65
30% to 100%*	19.5 to 65.0	100	2.26

Negative % of Test Load	Negative Pressure Range (psf)	Number Of Cycles	Average Cycle Time (Sec)
30% to 100%*	19.5 to 65.0	50	2.17
50% to 80%	32.5 to 52.0	1050	1.37
0% to 60%	0.0 to 39.0	50	1.93
20% to 50%	13.0 to 32.5	3350	2.69
*Panel deflected 1.75" from original plane at 100% Positive load and 1.75" from original plane at 100% Negative load. At the completion of cycles the door panel was operable. There were no tears in the film. In our opinion, the tape and film used to seal for air leakage did not influence the results of the test.			

Jarrett Wright and James Hayhurst, Test Technicians

Mfg Observers – Joe Zammit

## Conditions, Terms, and General Notes Regarding These Tests

The product tested Has Been compared to the detailed drawing, bill of materials and fabrication information supplied by the client so named herein. Our analysis, which includes dimensional and component description comparisons, indicate the tested product and engineering information supplied by the client "Are Equivalent". The report and representative samples will be retained for four years from the date of initial test.

These test results were obtained by employing all requirements of the designated test methods with no Deviations unless explicitly noted in test report. The test results and specimen supplied for testing are in compliance with the reference.

The test results are specific to the product tested by this laboratory and of the sample supplied by the client named herein, and they relate to no other product either manufactured by the client, a fabricator of the client or of the client or of installed field performance.

This test report does not constitute certification of this product, but only that the above test results were obtained using the designated test methods and they indicate compliance with the performance requirements (paragraphs as listed) of the above referenced specifications.

Testing Evaluation Laboratories, Inc. makes no opinions or endorsements regarding this product and its performance. This report may not be reproduced or quoted in partial form without the expressed written approval of Testing Evaluation Laboratories, Inc.

Testing Evaluation Laboratories, Inc.'s letter, reports, its name or insignia or mark are for the exclusive use of the client so named herein and any other use is strictly prohibited. The report, letters and the name of Testing Evaluation Laboratories, Inc., its seal or mark shall not be used in any circumstance to the general public or in any advertising.

Limitation of liability: Due diligence was used in performing the tests and reporting the results. By acceptance of this report, this client agrees to hold harmless and indemnify Testing Evaluation Laboratories, Inc., its employees, sub-contractors, officers and owners against all claims and demands of any kind whatsoever, which arise out of or in any manner connected with the performance of work referred to herein.

Testing Evaluation Laboratories, Inc.



Vivian K. Wright,  
President

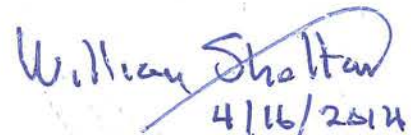

William B. Shelton, P.E.  
Florida P.E. # 26686

**Revision Log**

Rev No.	Date	Page(s)	Revision(s)
0	10/21/2013	NA	Original Report Issue





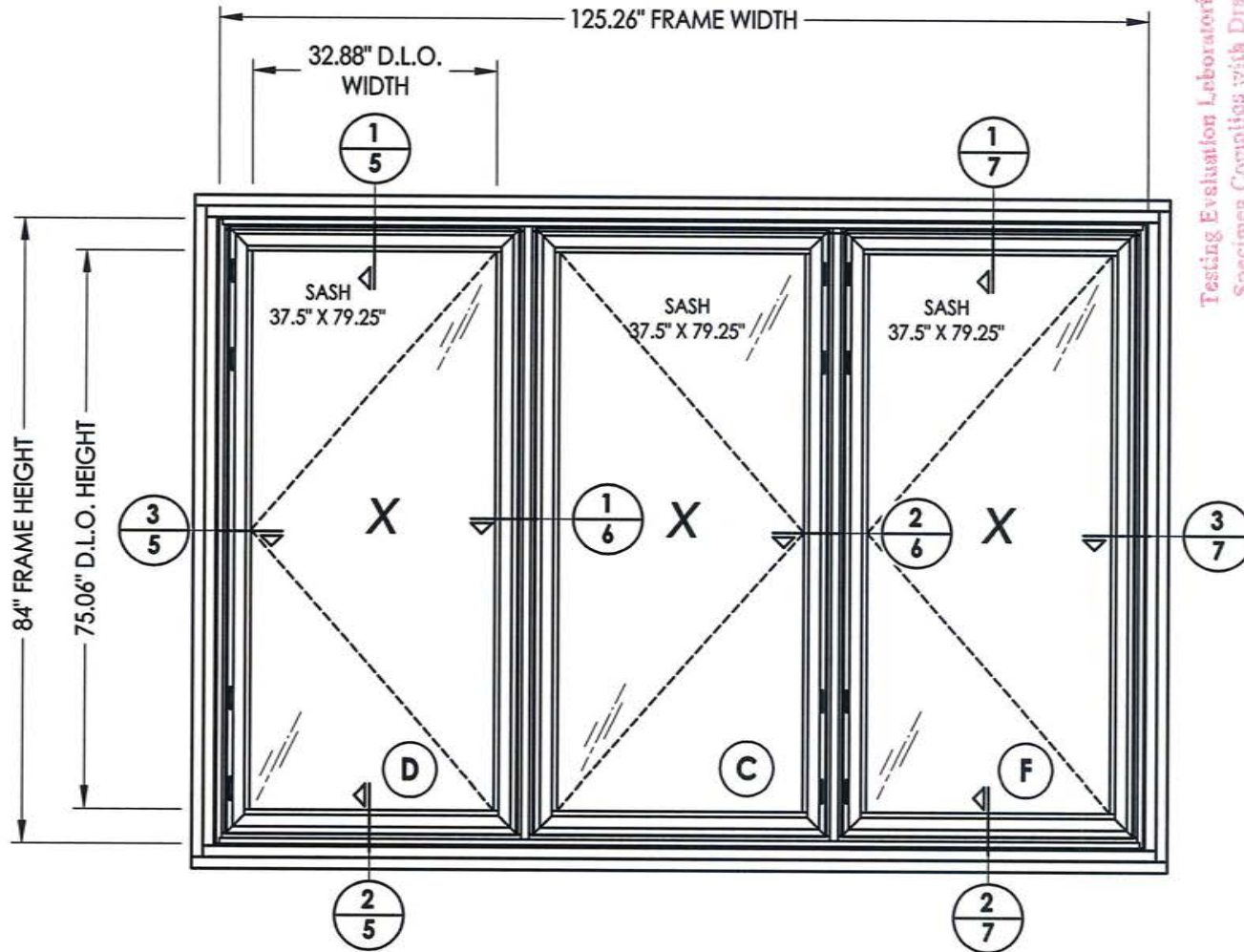

Testing Evaluation Laboratories Inc  
 Specimens Complies with Drawing  
 Deviations Noted - TEL # 01990816  
 Date 10/31/13 verified by *Y. Liu*

**SPEC. #4, 4A**

PRODUCT:		FLEETWOOD KONA 3800 CASEMENT WINDOW	
PART OR ASSEMBLY:		TEST ELEVATION	
NO.	DATE	REVISIONS	BY
RW BUILDING CONSULTANTS, INC. 813.659.9197			
DATE: 9/25/13			
SCALE: N.T.S.			
DWG. BY: JK			
CHK. BY: LFS			
DRAWING NO.: L-7031			
SHEET 3 OF 13			

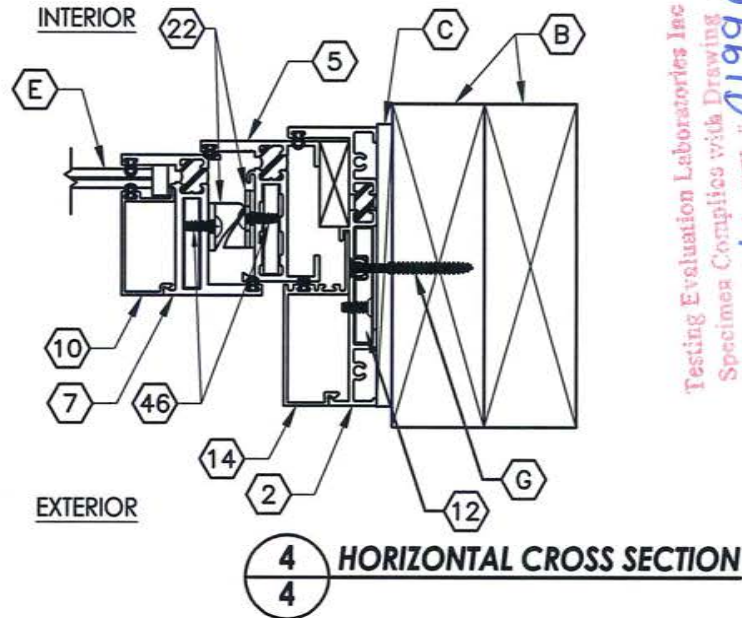
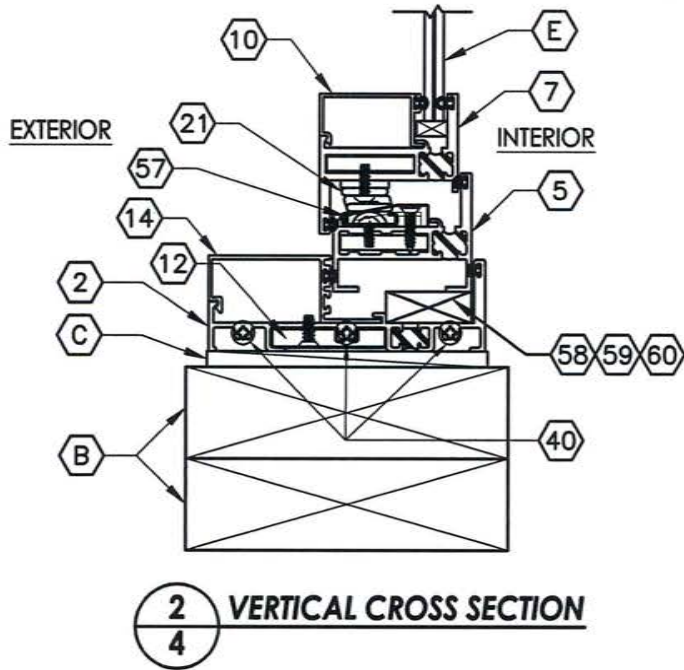
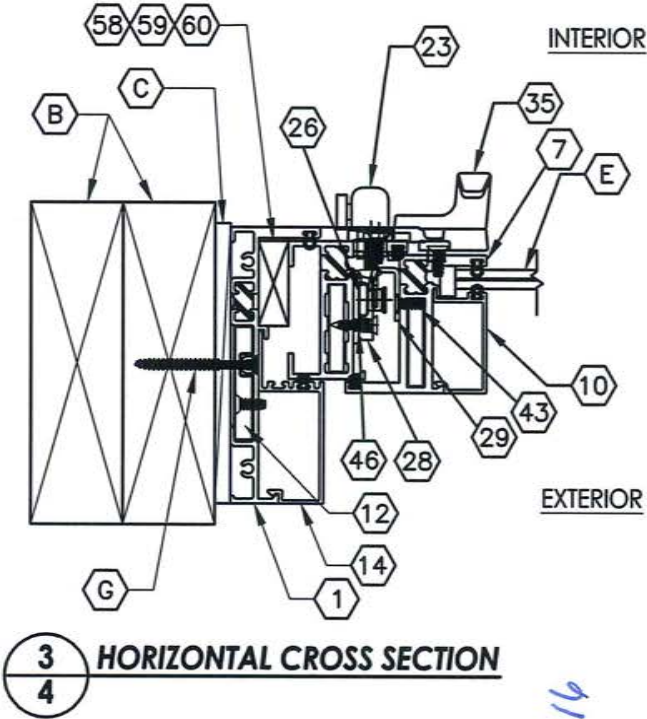
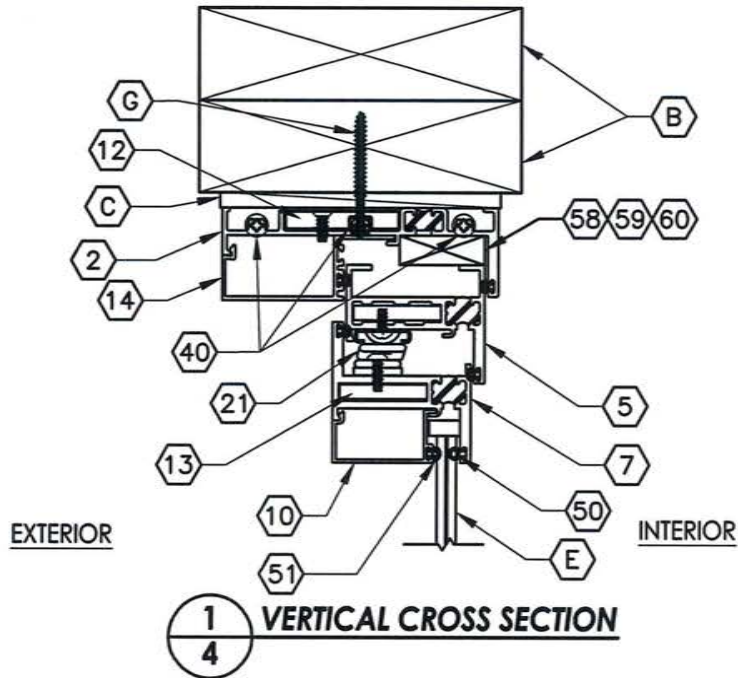

Testing Evaluation Laboratories Inc  
 Specimen Complies with Drawing  
 Deviation No. 01990814  
 Date 10/31/13 Verified by JLM

PRODUCT: FLEETWOOD KONA 3800 CASEMENT WINDOW		PART OR ASSEMBLY: HORIZONTAL AND VERTICAL CROSS SECTIONS	
NO.	DATE	REVISIONS	BY
RW BUILDING CONSULTANTS, INC. 813.659.9197			
DATE: 9/25/13			
SCALE: N.T.S.			
DWG. BY: JK			
CHK. BY: LFS			
DRAWING NO.: L-7031			
SHEET 4 OF 13			

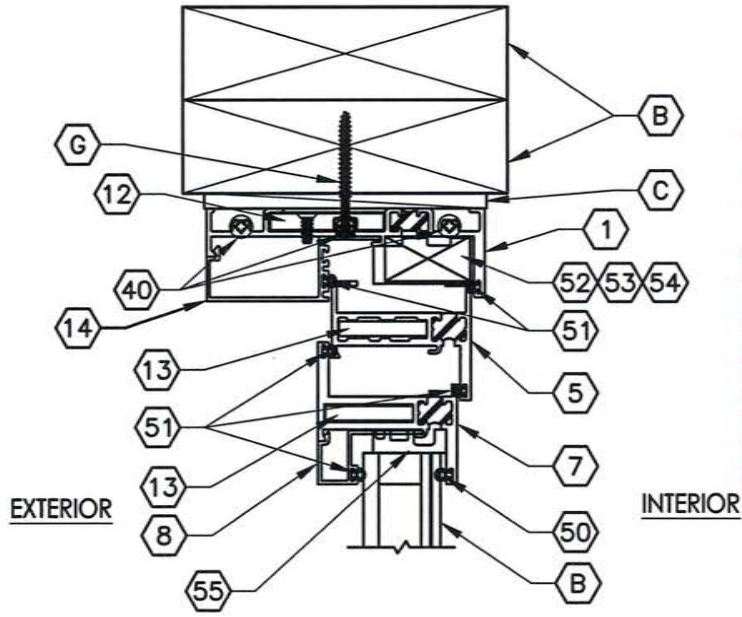

**1** VERTICAL CROSS SECTION  
**5**

Testing Evaluation Laboratories Inc  
Specimen Complies with Drawing  
Deviation Noted - TEL #01990816  
Date: 10/31/13

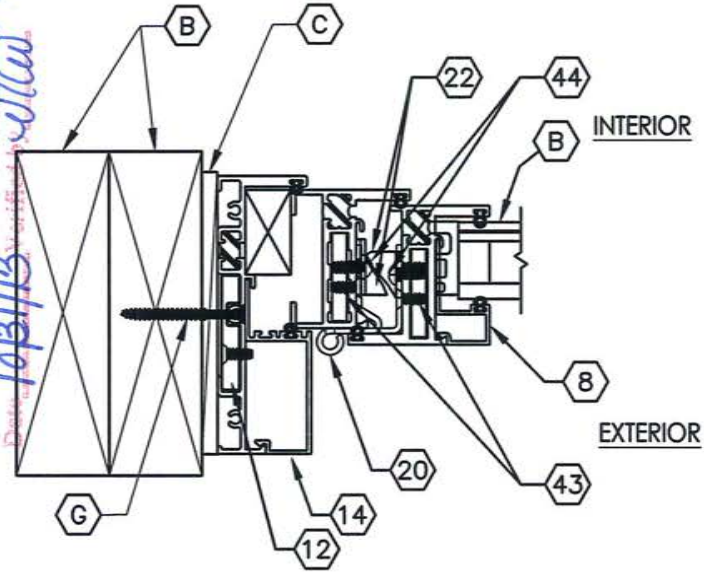

**3** HORIZONTAL CROSS SECTION  
**5**

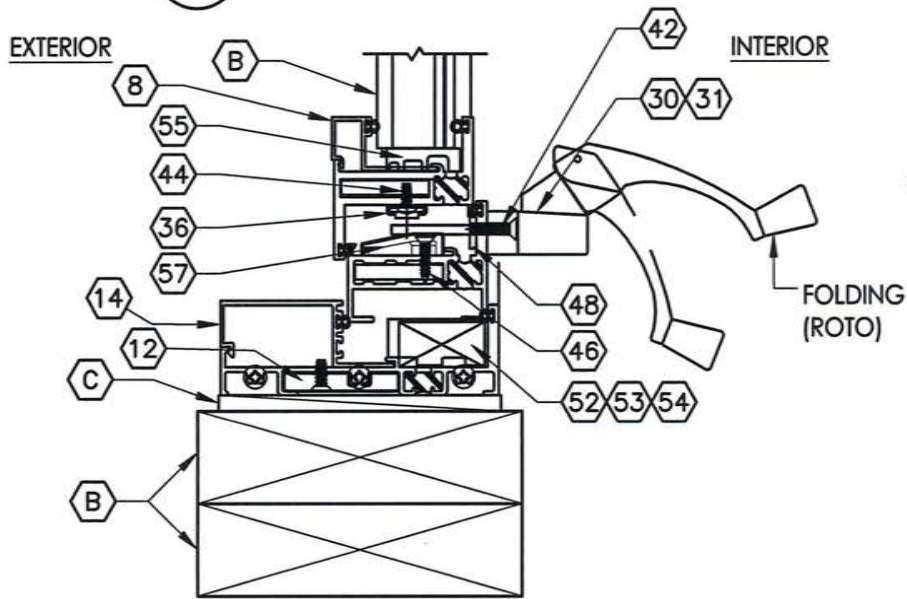

**2** VERTICAL CROSS SECTION  
**5**

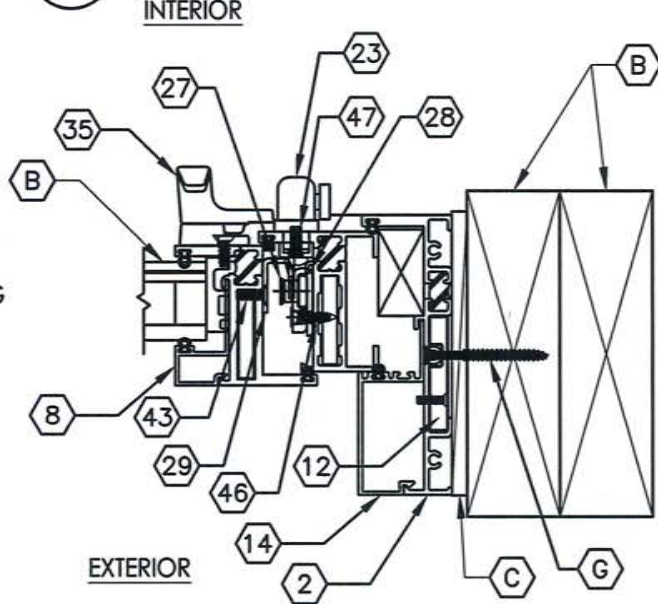

**4** HORIZONTAL CROSS SECTION  
**5**

PRODUCT:		FLEETWOOD KONA 3800 CASEMENT WINDOW	
PART OR ASSEMBLY:		HORIZONTAL AND VERTICAL CROSS SECTIONS	
NO.	DATE	REVISIONS	BY
 RW BUILDING CONSULTANTS, INC. 813.659.9197			
DATE: 9/25/13			
SCALE: N.T.S.			
DWG. BY: JK			
CHK. BY: LFS			
DRAWING NO.: L-7031			
SHEET 5 OF 13			

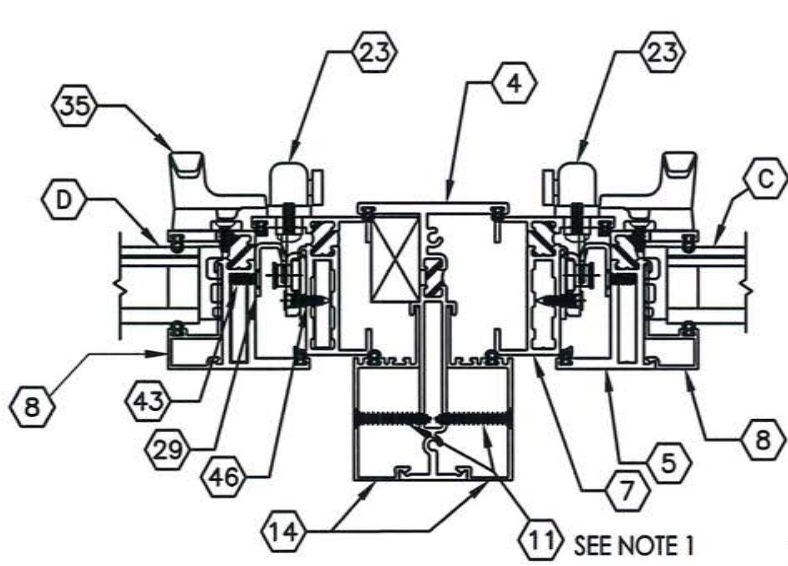

**1**  
**6** **HORIZONTAL CROSS SECTION**

INTERIOR

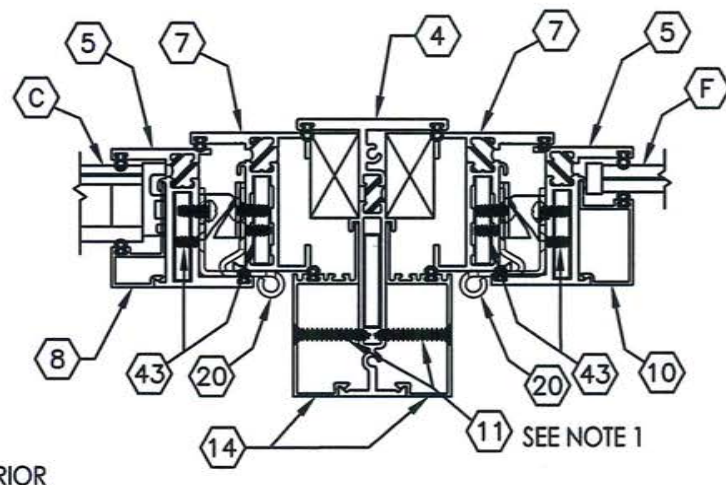

**2**  
**6** **HORIZONTAL CROSS SECTION**

EXTERIOR

Testing Evaluation Laboratories Inc  
 Specimen Complies with Drawing  
 Deviation Noted - TEL # 01990816  
 Date: 10/31/13 Verified by: *[Signature]*

**NOTE:**

- Item #11 located 4" from each end then 12" on center for (8) total.

PRODUCT:		FLEETWOOD KONA 3800 CASEMENT WINDOW	
PART OR ASSEMBLY:		HORIZONTAL CROSS SECTIONS	
NO.	DATE	REVISIONS	BY
 RW BUILDING CONSULTANTS, INC. 813.659.9197			
DATE: 9/25/13		SCALE: N.T.S.	
DWG. BY: JK		CHK. BY: LFS	
DRAWING NO.: L-7031		SHEET 6 OF 13	

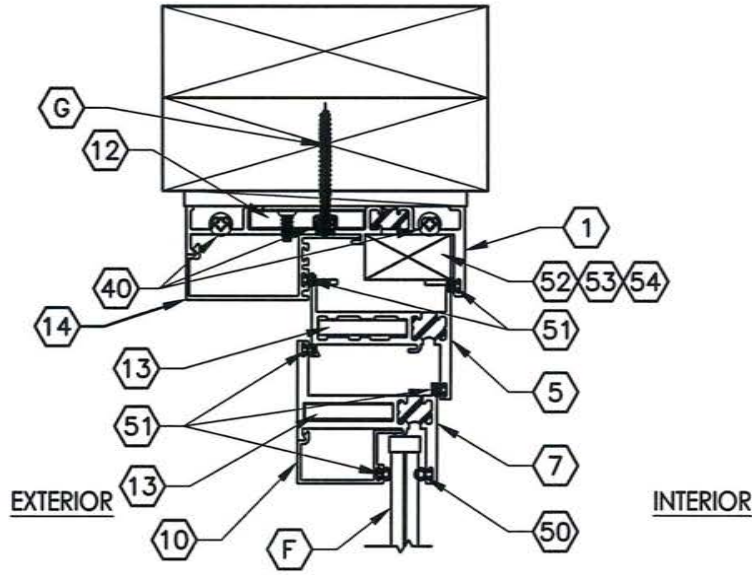

**1**  
**7** VERTICAL CROSS SECTION

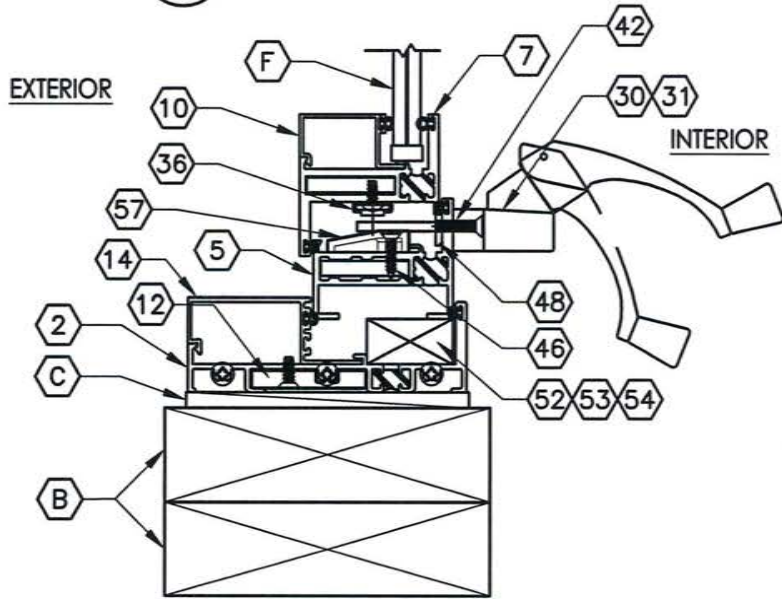

**2**  
**7** VERTICAL CROSS SECTION

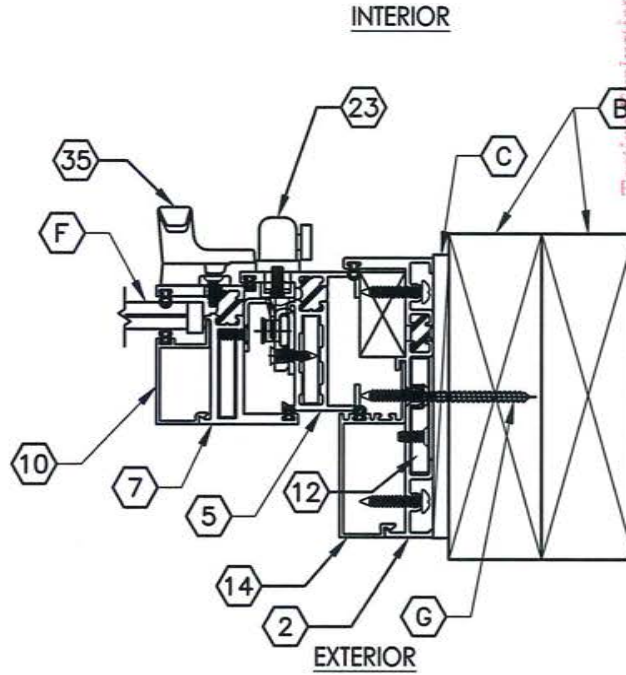

**3**  
**7** HORIZONTAL CROSS SECTION

Testimonial Laboratories Inc  
 Specimens Complies with Drawing  
 Deviation Noted - TEL # 019990816  
 Date 10/31/13 verified by *W. Cal*

PRODUCT:		FLEETWOOD KONA 3800 CASEMENT WINDOW	
PART OR ASSEMBLY:		HORIZONTAL AND VERTICAL CROSS SECTIONS	
NO.	DATE	REVISIONS	BY
RW BUILDING CONSULTANTS, INC. 813.659.9197			
DATE:		9/25/13	
SCALE:		N.T.S.	
DWG. BY:		JK	
CHK. BY:		LFS	
DRAWING NO.:		L-7031	
SHEET		7 OF 13	

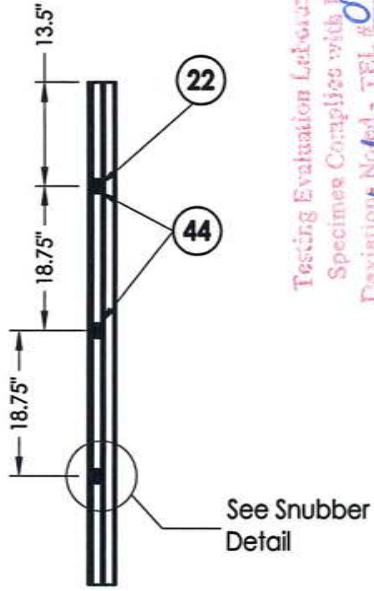

**SNUBBERS JAMB**

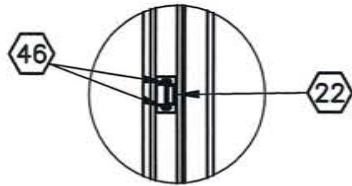

**SNUBBER DETAIL**

Testing Evaluation Laboratories Inc  
 Specimens Complies with Drawing  
 Deviation Noted - TEL # 01990814  
 Date 10/31/13 Verified by JWW

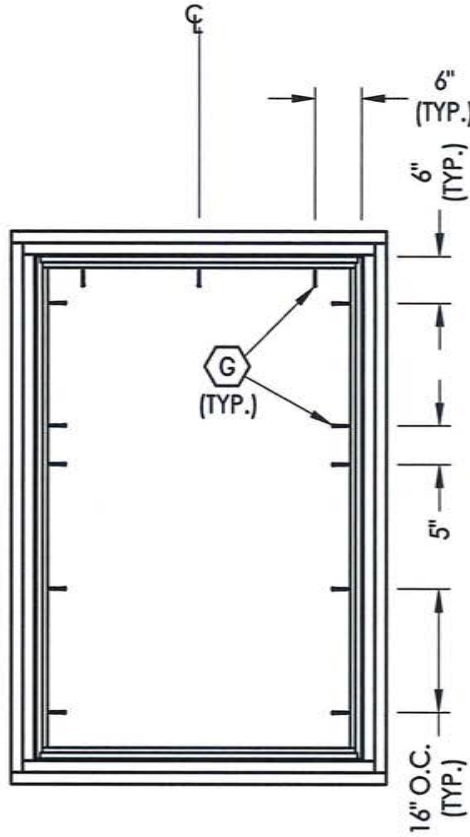

**FRAME ANCHORING**  
 2X buck construction

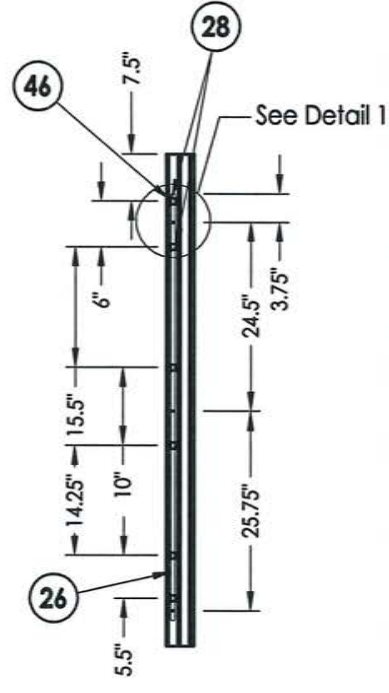

**LOCK JAMB**  
 Locking Points (3)

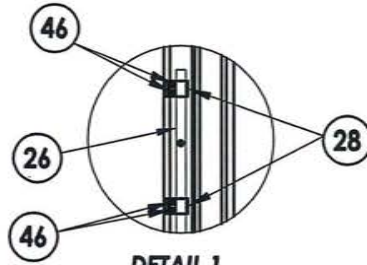

**DETAIL 1**

PRODUCT:		FLEETWOOD KONA 3800 CASEMENT WINDOW	
PART OR ASSEMBLY:		FRAME ANCHORING	
NO.	DATE	BY	REVISIONS
 RW BUILDING CONSULTANTS, INC. 813.659.9197			
DATE: 9/25/13			
SCALE: N.T.S.			
DWG. BY: JK			
CHK. BY: LFS			
DRAWING NO.: L-7031			
SHEET 8 OF 13			

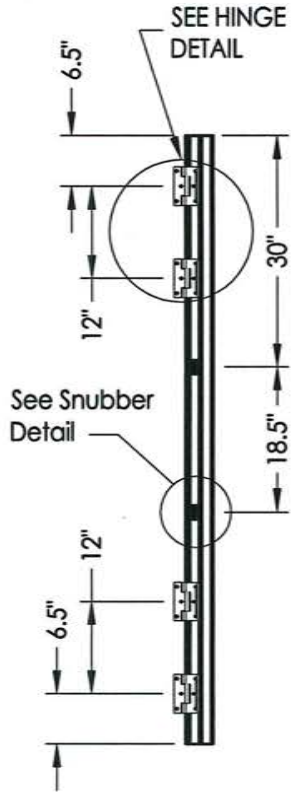
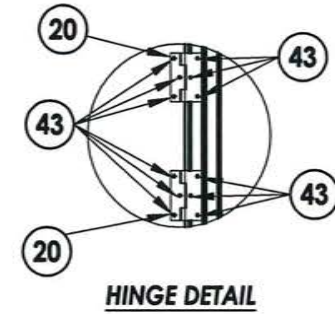

Testing Evaluation Laboratories Inc  
 Specimen Complies with Drawing  
 Deviations/Notes: TEL # 019990814  
 Date: 11/31/13 certified by JKW

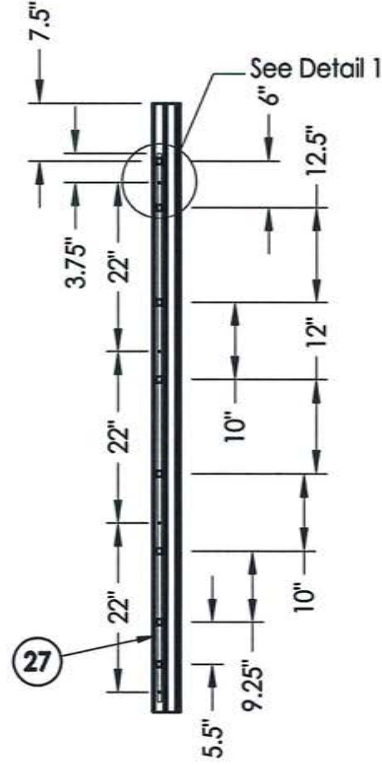
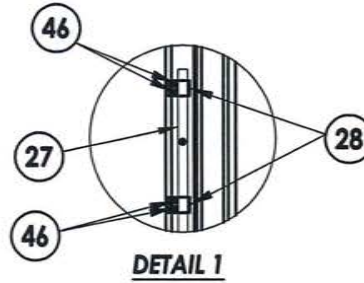
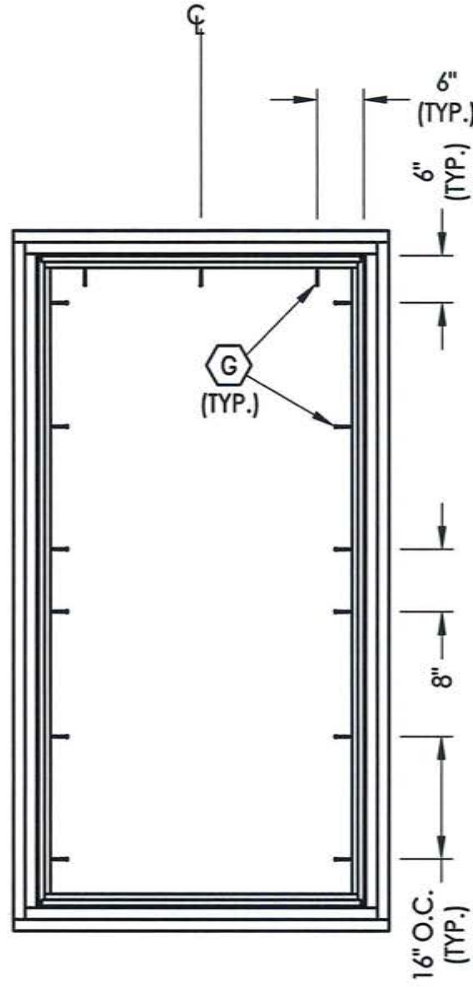
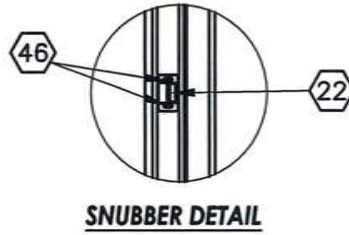

PRODUCT:		FLEETWOOD KONA 3800 CASEMENT WINDOW	
PART OR ASSEMBLY:		FRAME ANCHORING	
NO.	DATE	REVISIONS	BY
DATE: 9/25/13			
SCALE: N.T.S.			
DWG. BY: JK			
CHK. BY: LFS			
DRAWING NO.: L-7031			
SHEET 9 OF 13			

Testing Evaluation Laboratories Inc  
 Specimen Complies with Drawing  
 Deviations Noted - TEL # 01990816  
 Date 10/31/13 Verified by *WAW*

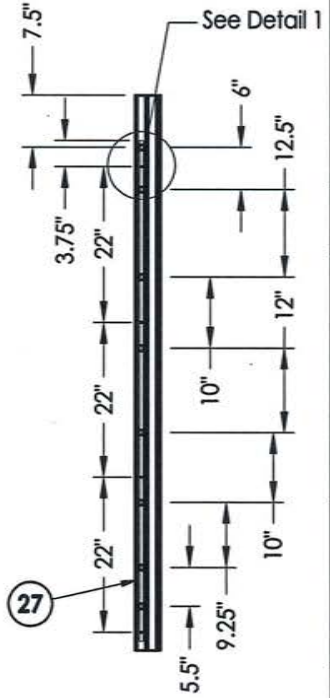
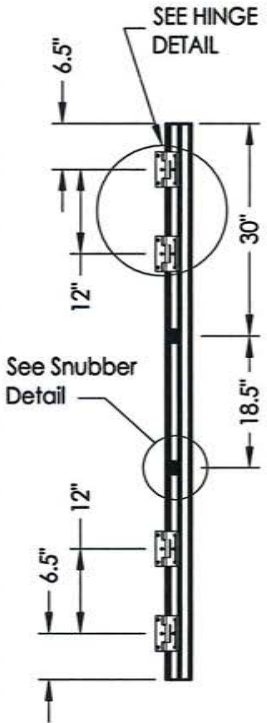
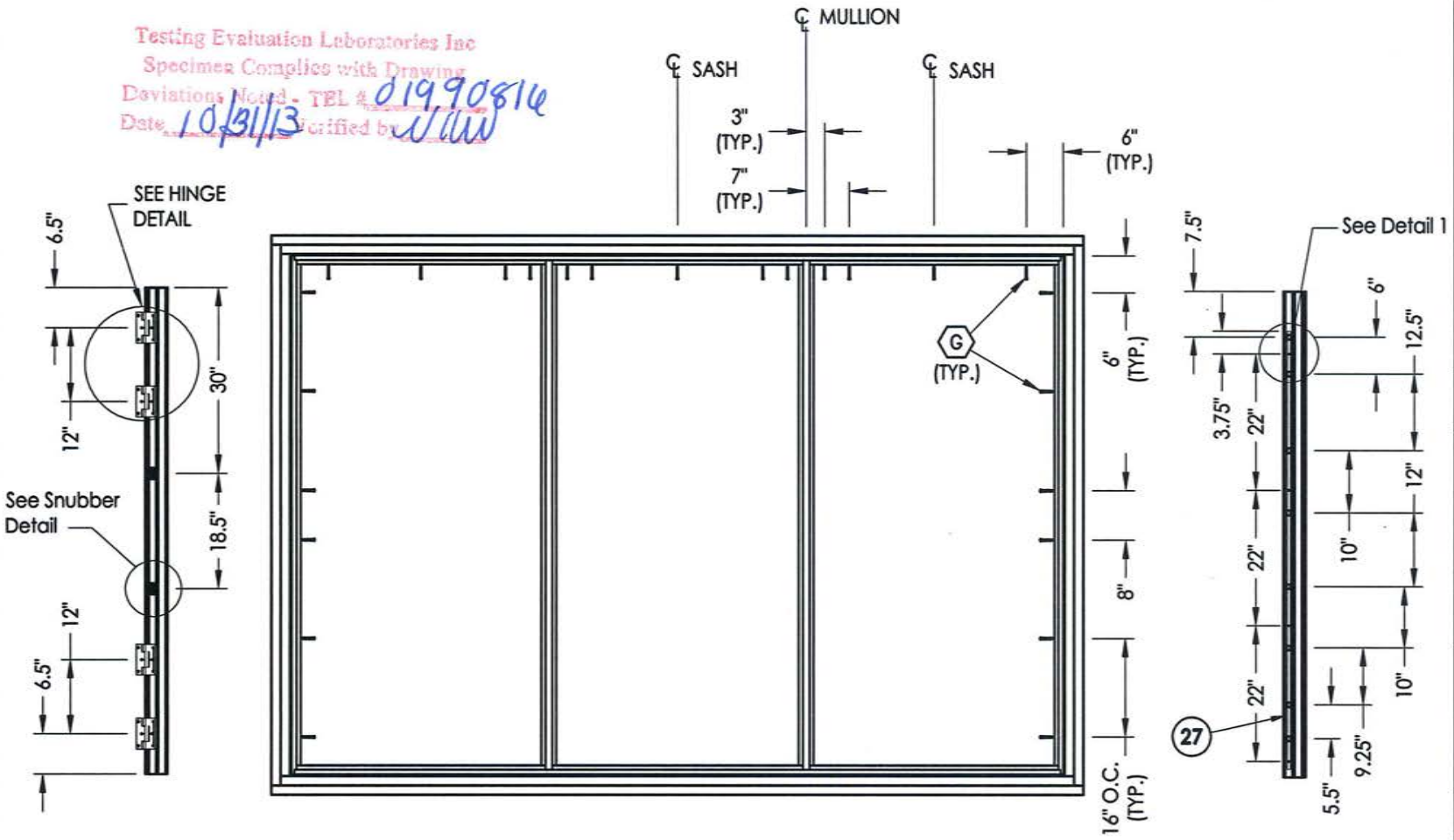

**HINGE JAMB**

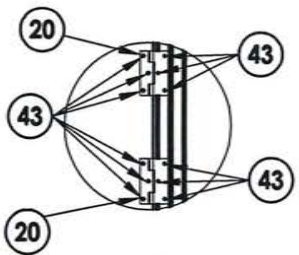

**HINGE DETAIL**

**FRAME ANCHORING**  
 2X buck construction



**SNUBBER DETAIL**

**LOCK JAMB**

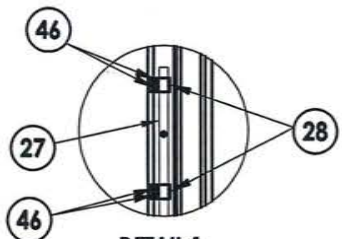

**DETAIL 1**

PRODUCT: <b>FLEETWOOD                  KONA 3800                  CASEMENT WINDOW</b>	
PART OR ASSEMBLY: <b>FRAME ANCHORING</b>	
NO.	DATE
BY	REVISIONS
RW BUILDING CONSULTANTS, INC. 813.659.9197	
DATE:	9/25/13
SCALE:	N.T.S.
DWG. BY:	JK
CHK. BY:	LFS
DRAWING NO.:	L-7031
SHEET	10 OF 13

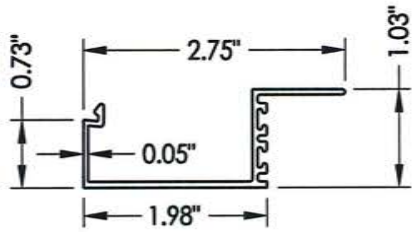

**14** **INSERT STOP**  
011448

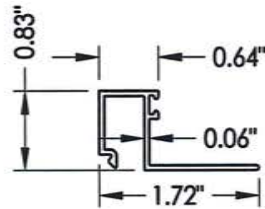

**8** **GLASS STOP 1-1/4"**  
901487

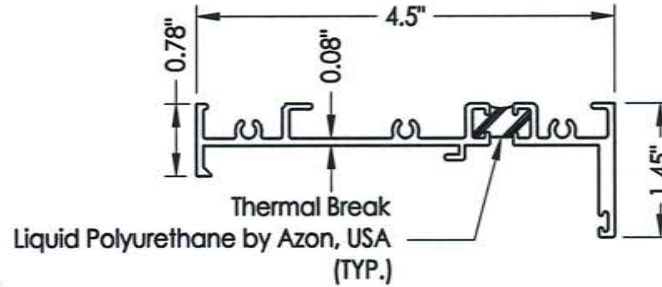

**2** **KONA BLOCK FRAME**  
011239

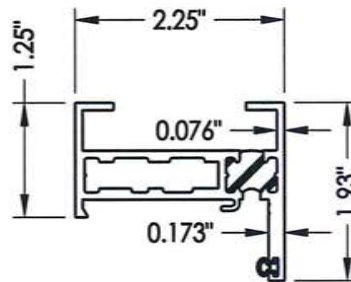

**5** **BLOCK FRAME**  
5278C1

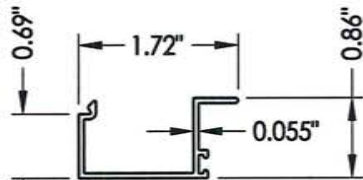

**10** **GLASS STOP 5/16\", 7/16"**  
007930

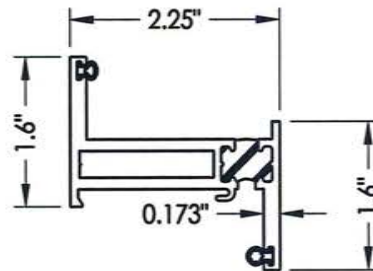

**7** **ZEE BAR (PANEL)**  
H006733

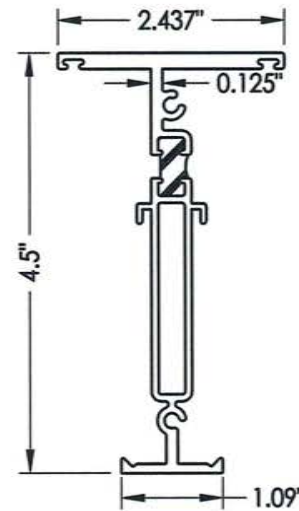

**4** **MULLION**  
H011241

Testing Evaluation Laboratories Inc  
Specimen Complies with Drawing  
Deviations Noted - TEL # 01990816  
Date 10/31/13 Verified by [Signature]

PRODUCT: FLEETWOOD KONA 3800 CASEMENT WINDOW		PART OR ASSEMBLY: COMPONENTS	
NO.	DATE	REVISIONS	BY
DATE: 9/25/13			
SCALE: N.T.S.			
DWG. BY: JK			
CHK. BY: LFS			
DRAWING NO.: L-7031			
SHEET 11 OF 13			

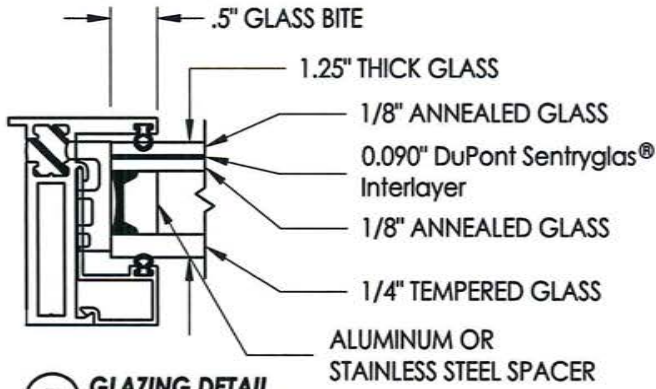

**B** GLAZING DETAIL

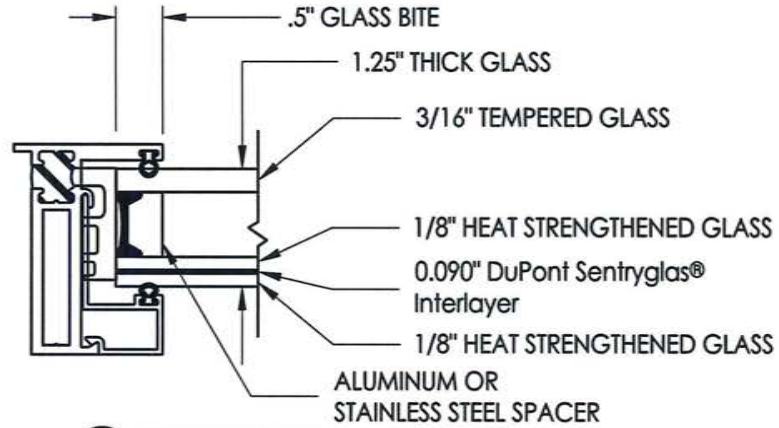

**C** GLAZING DETAIL

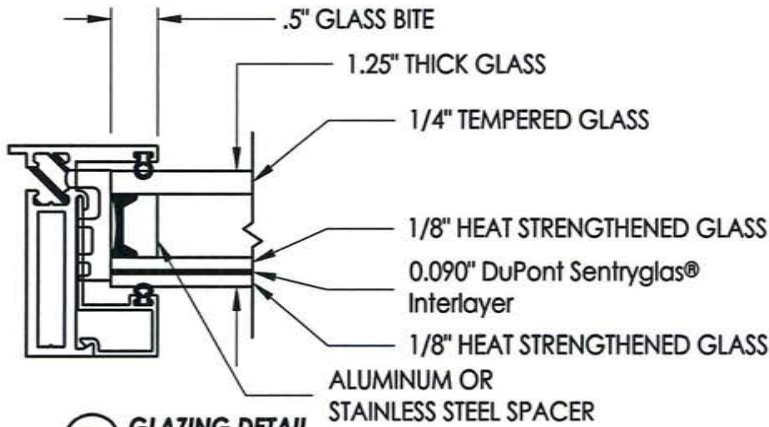

**D** GLAZING DETAIL

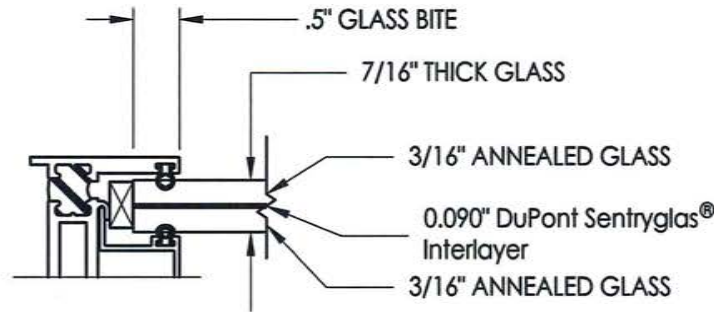

**F** GLAZING DETAIL

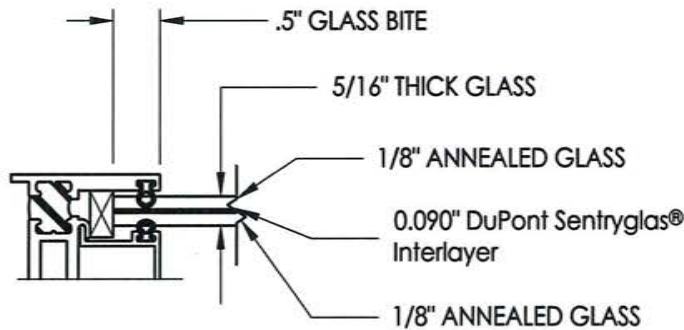

**E** GLAZING DETAIL

Testing Evaluation Laboratories Inc  
 Specimen Complies with Drawing  
 Deviations Noted - TEL # 0199.0816  
 Date 10/31/13 Verified by [Signature]

PRODUCT:		FLEETWOOD KONA 3800 CASEMENT WINDOW	
PART OR ASSEMBLY:		GLAZING DETAILS	
NO.	DATE	REVISIONS	BY
RW BUILDING CONSULTANTS, INC. 813.659.9197			
DATE: 9/25/13			
SCALE: N.T.S.			
DWG. BY: JK			
CHK. BY: LFS			
DRAWING NO.: L-7031			
SHEET 12 OF 13			

**BILL OF MATERIALS**

ITEM #	DESCRIPTION	MATERIAL
B	2X BUCK SG >= 0.55	WOOD
C	1/4" MAX. SHIM SPACE	-
G	#10 x 2" PPH WOOD SCREW	STEEL
2	KONA BLOCK FRAME	6063-T6 ALUM
4	MULLION	6063-T6 ALUM
5	WESTWOOD BLOCK FRAME	6063-T6 ALUM
7	WESTWOOD ZEE BAR (PANEL)	6063-T6 ALUM
8	GLASS STOP (1-1/4")	6063-T6 ALUM
9	GLASS STOP (1/4")	6063-T6 ALUM
10	GLASS STOP (5/16", 7/16")	6063-T6 ALUM
11	#8 x 1-1/2" PFH SMS	STEEL
12	SHEAR BLOCK	ALUM
13	CORNER KEY	ALUM
14	INSERT STOP	6063-T6 ALUM
20	SS. BUTT HINGE	SS
21	4 BAR HINGE	SS
22	SNUBBER-COMMERCIAL PULL-IN BLOCK	SS
23	MULTIPOINT LOCK HANDLE	SS
26	3 POINTS LOCKING BAR	SS
27	4 POINTS LOCKING BAR	SS
28	TIE BAR GUIDE	-
29	KEEPER	SS
30	CASEMENT ROTOR GEAR 13.5"	SS
35	CAM HANDLE / STRIKE PLATE	SS

36	CASEMENT SS. TRACK	SS
40	#10 X 1" PPH SMS	STEEL
42	MACHINE SCREW NO 10-32, FHP .75"	STEEL
43	SCREW NO 10 , UFHP .5"	STEEL
44	SCREW NO 8, PHP, .50"	STEEL
46	SCREW NO 8, FHP, .750"	STEEL
47	MACHINE SCREW NO 10-32, PHP .5"	STEEL
48	BACK UP NUTS	STEEL
50	BULB VINYL (EPDM 70 DUROMETER)-TREMCO	-
51	MINI BULB VINYL(EPDM 70 DUROMETER)-TREMCO	-
52	WOOD BLOCK .750" X 1.250"	-
53	ALUMINUM BLOCK .750" X 1.250"	-
54	PVC BLOCK .750" X 1.250"	-
55	SETTING BLOCK	-
56	SETTING BLOCK 4" x 1/2" x 1"	-
57	PIVOT SHIM	-
58	WOOD BLOCK .50" X 1.250"	-
59	ALUMINUM BLOCK .50" X 1.250"	-
60	PVC BLOCK .50" X 1.250"	-
61	SETTING BLOCK 4" x 1/8" x 1"	-

Testing Evaluation Laboratories Inc  
 Specimen Complies with Drawing  
 Deviation Noted - TEL # 0199.0814  
 Date 10/31/13 Verified by Jllw

<b>FLEETWOOD KONA 3800 CASEMENT WINDOW</b>	<b>BILL OF MATERIALS</b>	
PRODUCT:	PART OR ASSEMBLY:	
	NO.	DATE
	BY	REVISIONS
 <b>RW BUILDING CONSULTANTS, INC.</b> 813.659.9197		
DATE:	9/25/13	
SCALE:	N.T.S.	
DWG. BY:	JK	
CHK. BY:	LFS	
DRAWING NO.:	L-7031	
SHEET	13 OF 13	





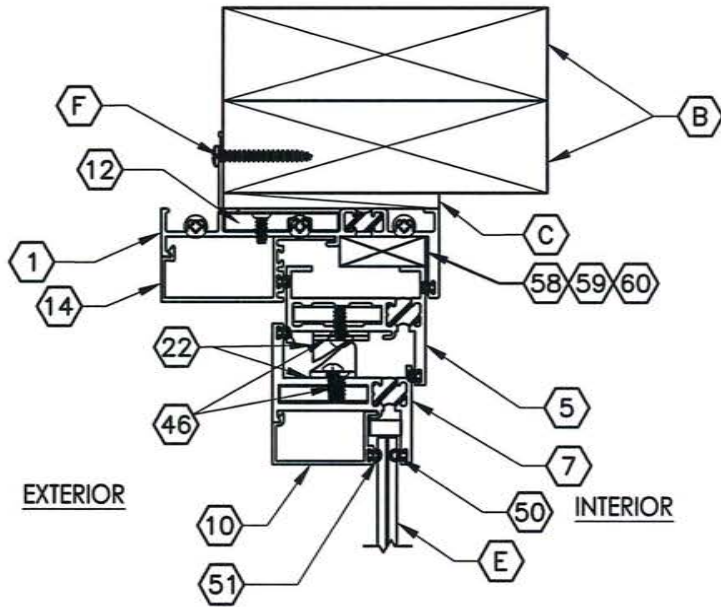

**1** VERTICAL CROSS SECTION  
**3**

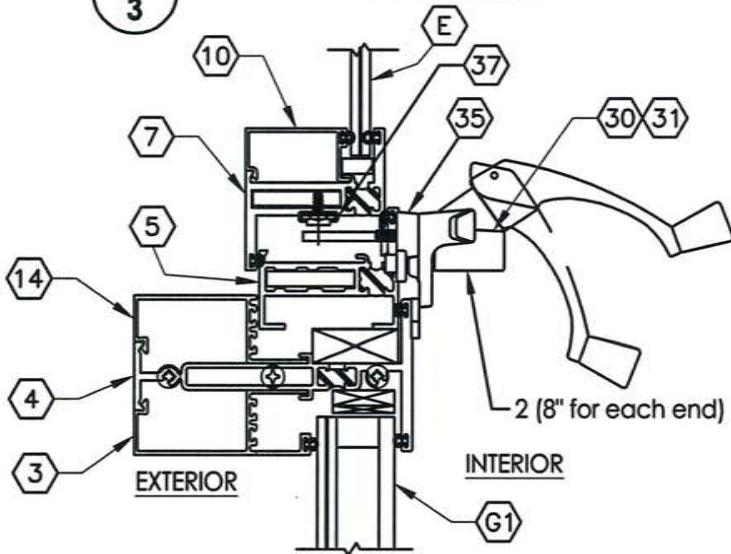

**2** VERTICAL CROSS SECTION  
**3**

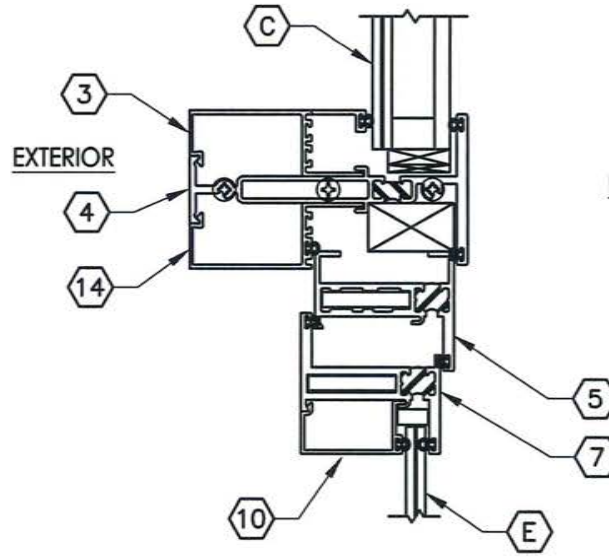

**3** VERTICAL CROSS SECTION  
**3**

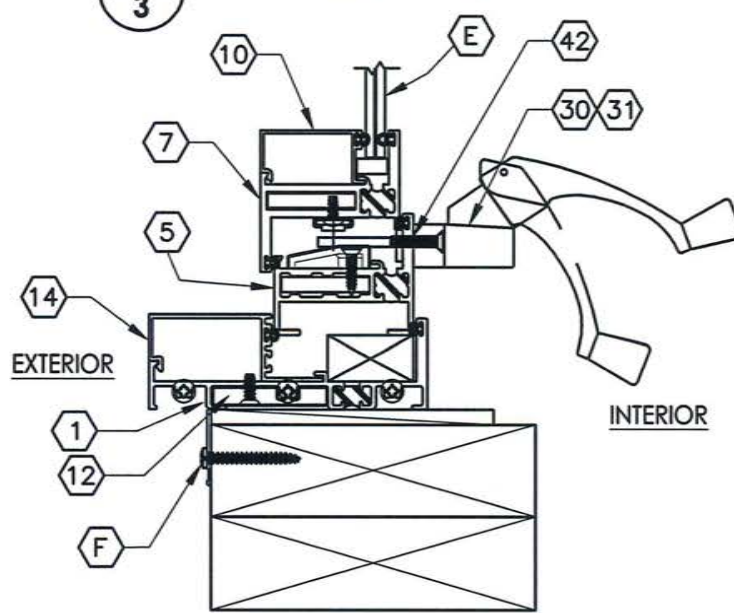

**4** VERTICAL CROSS SECTION  
**3**

Testing Evaluation Laboratories Inc  
Specimens Complies with Drawing  
Deviation Noted - TEL # 813.659.9197  
Date 10/31/13 Verified by JLM

PRODUCT:		FLEETWOOD KONA 3800 CASEMENT WINDOW	
PART OR ASSEMBLY:		VERTICAL CROSS SECTIONS	
NO.	DATE	REVISIONS	BY
 BUILDING CONSULTANTS, INC. 813.659.9197			
DATE: 9/25/13			
SCALE: N.T.S.			
DWG. BY: JK			
CHK. BY: LFS			
DRAWING NO.: L-7032			
SHEET 3 OF 12			

Testing Evaluation Laboratories Inc  
 Specimen Complies with Drawing  
 Deviation Noted - TEL # 019990816  
 Date: 10/31/13 Verified by: *WLL*

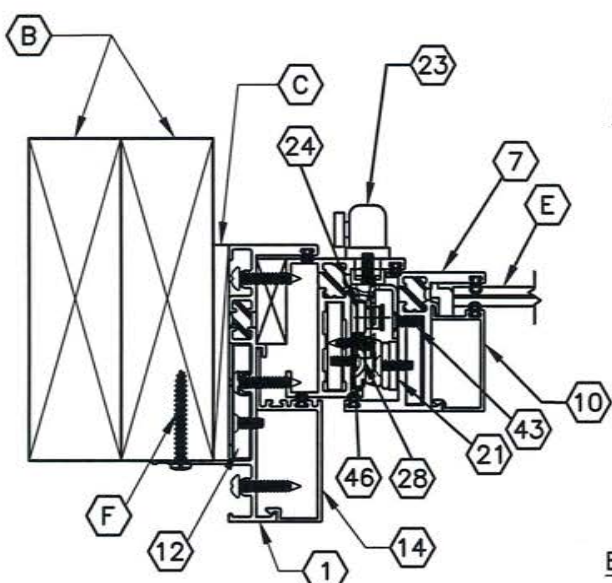

**1**  
**4** **HORIZONTAL CROSS SECTION**

INTERIOR

EXTERIOR

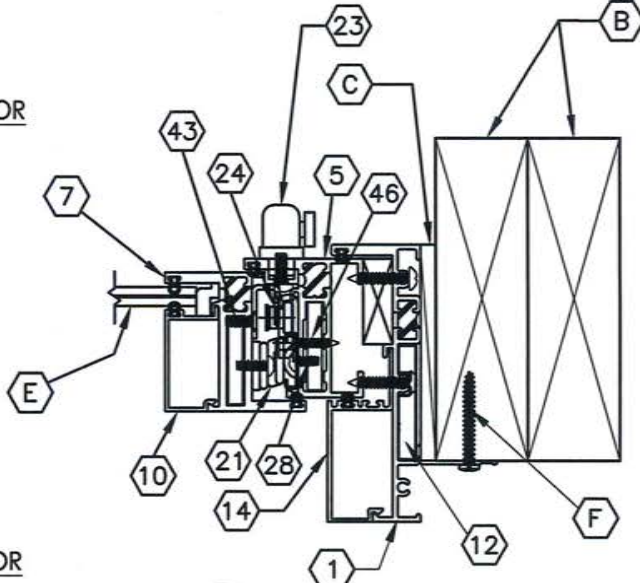

**2**  
**4** **HORIZONTAL CROSS SECTION**

INTERIOR

EXTERIOR

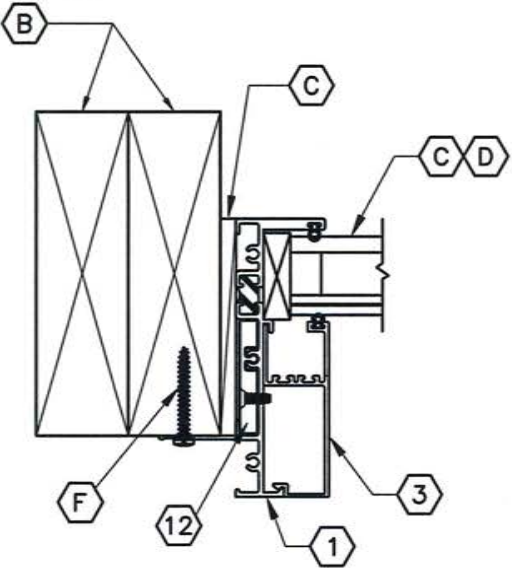

**3**  
**4** **HORIZONTAL CROSS SECTION**

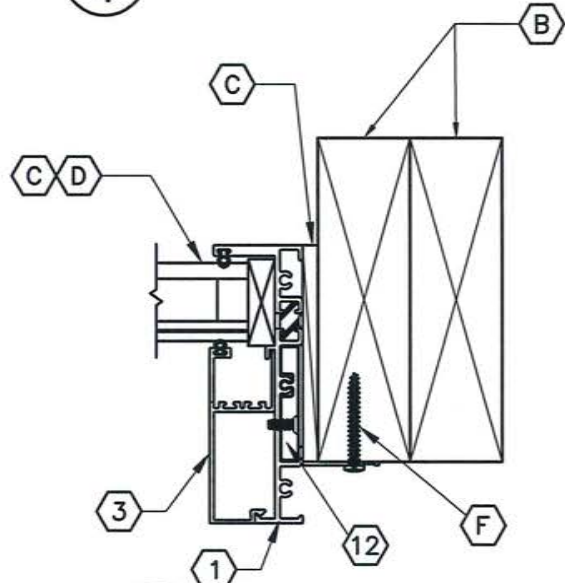

**4**  
**4** **HORIZONTAL CROSS SECTION**

PRODUCT:		FLEETWOOD KONA 3800 CASEMENT WINDOW	
PART OR ASSEMBLY:		HORIZONTAL CROSS SECTIONS	
NO.	DATE	BY	REVISIONS
 BUILDING CONSULTANTS, INC. 813.659.9197			
DATE: 9/25/13			
SCALE: N.T.S.			
DWG. BY: JK			
CHK. BY: LFS			
DRAWING NO.:			
L-7032			
SHEET 4 OF 12			

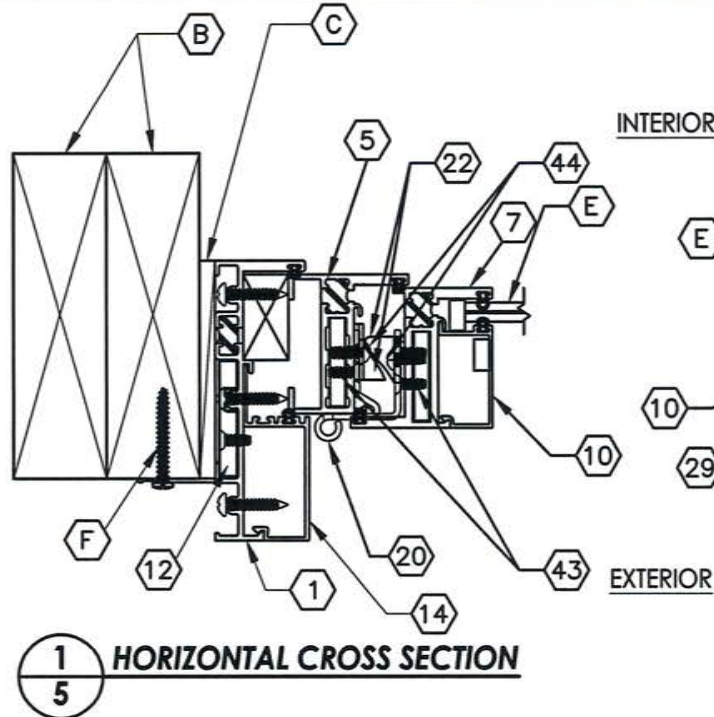

INTERIOR

EXTERIOR

**1**  
5 HORIZONTAL CROSS SECTION

INTERIOR

EXTERIOR

**3**  
5 HORIZONTAL CROSS SECTION

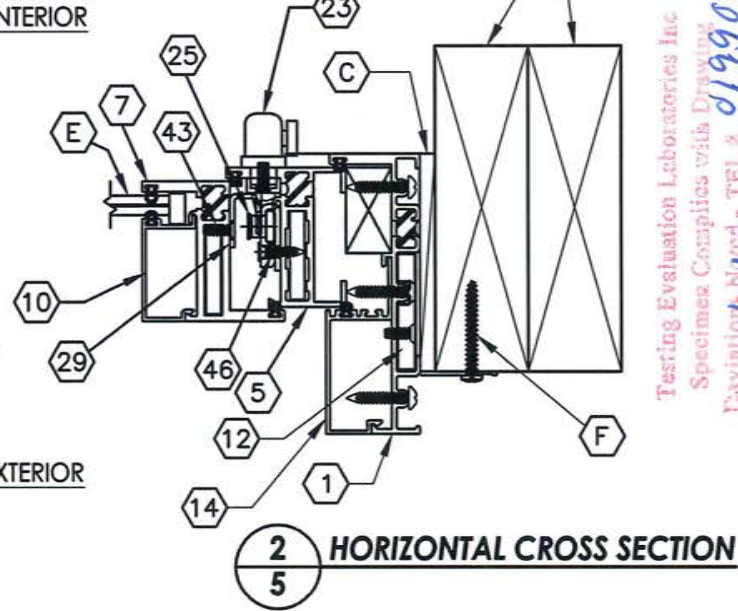

**2**  
5 HORIZONTAL CROSS SECTION

INTERIOR

EXTERIOR

**4**  
5 HORIZONTAL CROSS SECTION

Testing Evaluation Laboratories Inc  
 Specimen Complies with Drawing  
 Deviation Noted - TEL # 01990816  
 Date 10/21/13 M. J. W.

PRODUCT:		FLEETWOOD KONA 3800 CASEMENT WINDOW	
PART OR ASSEMBLY:		HORIZONTAL CROSS SECTIONS	
NO.	DATE	BY	REVISIONS
 RW BUILDING CONSULTANTS, INC. 813.659.9197			
DATE: 9/25/13			
SCALE: N.T.S.			
DWG. BY: JK			
CHK. BY: LFS			
DRAWING NO.: L-7032			
SHEET 5 OF 12			

Testing Evaluation Laboratories Inc  
 Specimen Complies with Drawing  
 Evaluations Noted - TEL # 800-871-1111  
 Date 10/31/13 Submitted by Jllw

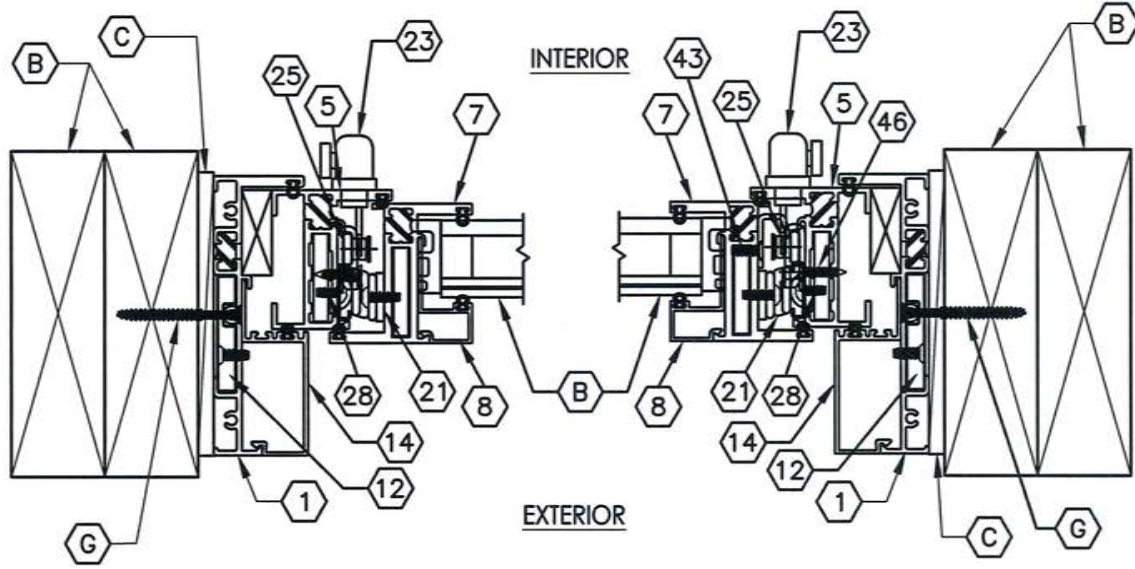

**1**  
6 **HORIZONTAL CROSS SECTION**

**2**  
6 **HORIZONTAL CROSS SECTION**

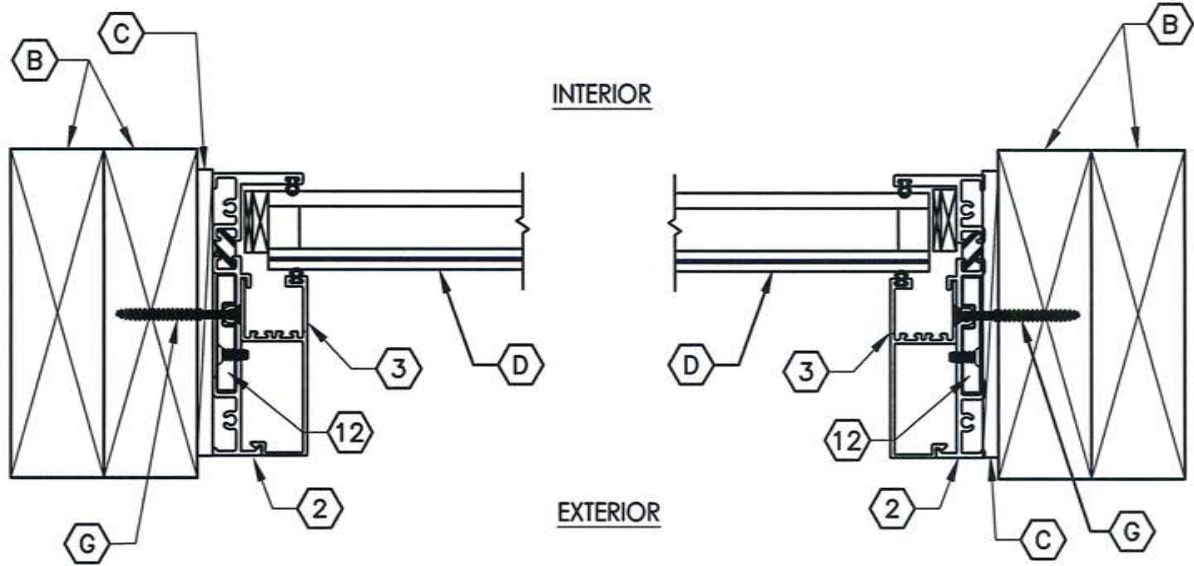

**3**  
6 **HORIZONTAL CROSS SECTION**

**4**  
6 **HORIZONTAL CROSS SECTION**

PRODUCT:		FLEETWOOD KONA 3800 CASEMENT WINDOW	
PART OR ASSEMBLY:		HORIZONTAL CROSS SECTIONS	
NO.	DATE	BY	REVISIONS
RW BUILDING CONSULTANTS, INC. 813.659.9197			
DATE: 9/25/13			
SCALE: N.T.S.			
DWG. BY: JK			
CHK. BY: LFS			
DRAWING NO.: L-7032			
SHEET 6 OF 12			

Testing Evaluation Laboratories Inc  
 Specimen Complies with Drawing  
 Deviation No. 01990816  
 Date 10/31/13  
 Approved by: DLU

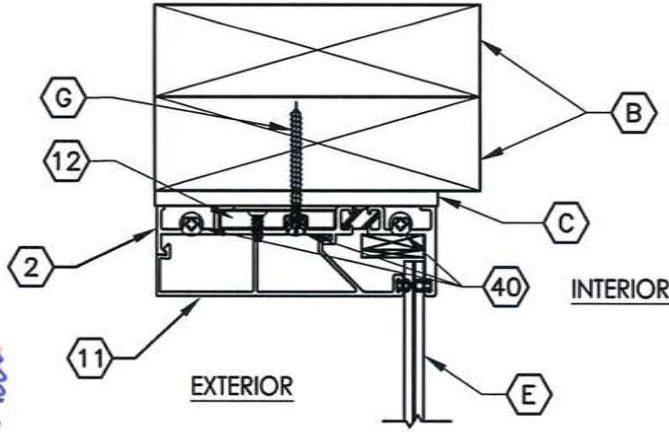

1  
7 **VERTICAL CROSS SECTION**

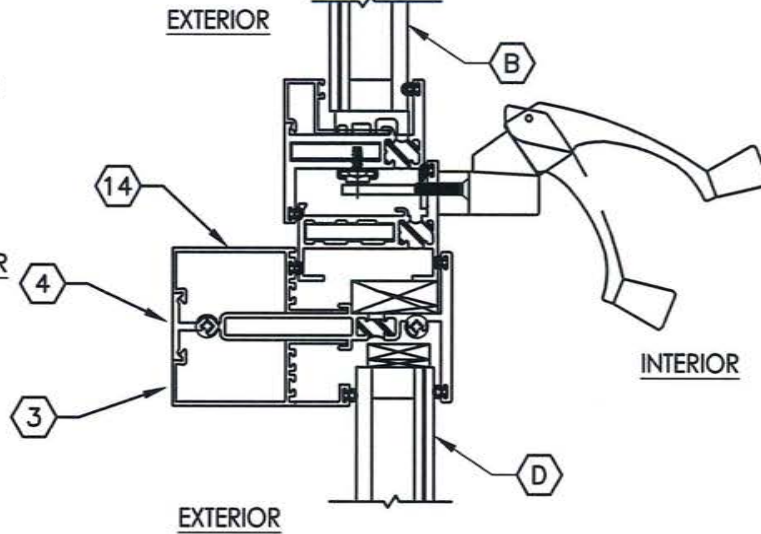

3  
7 **VERTICAL CROSS SECTION**

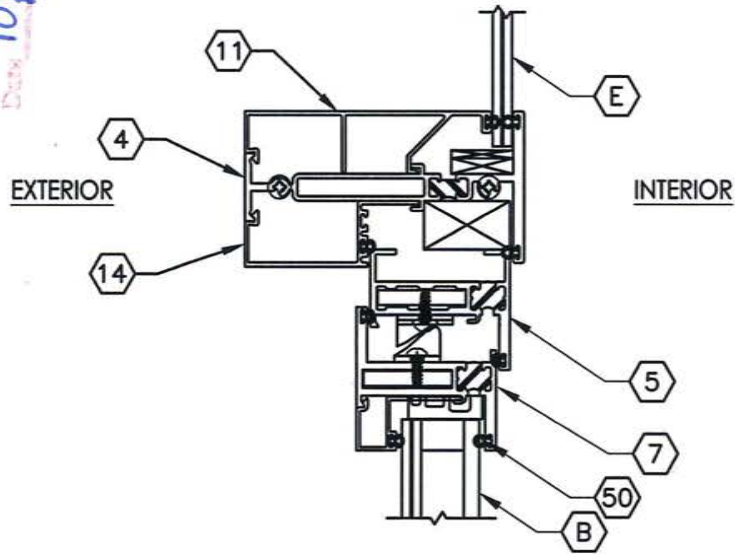

2  
7 **VERTICAL CROSS SECTION**

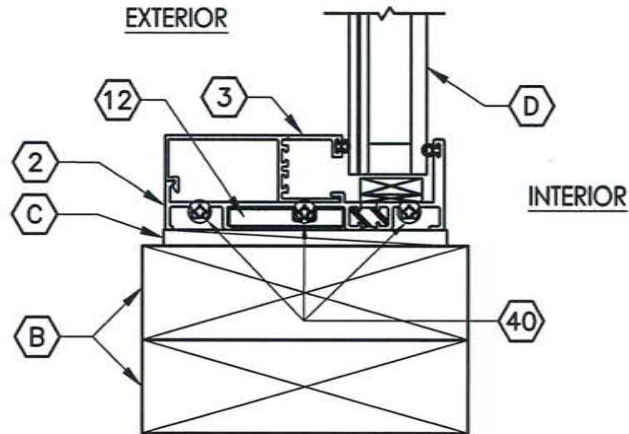

4  
7 **VERTICAL CROSS SECTION**

PRODUCT:		FLEETWOOD KONA 3800 CASEMENT WINDOW	
PART OR ASSEMBLY:		VERTICAL CROSS SECTIONS	
NO.	DATE	BY	REVISIONS
RW BUILDING CONSULTANTS, INC. 813.659.9197			
DATE: 9/25/13			
SCALE: N.T.S.			
DWG. BY: JK			
CHK. BY: LFS			
DRAWING NO.: L-7032			
SHEET 7 OF 12			

Testing Evaluation Laboratories Inc  
 Specimen Complies with  
 Deviation Noted - TEL. #  
 Date: 10/31/13 Validated by: elw

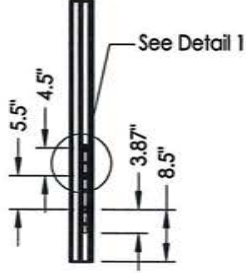
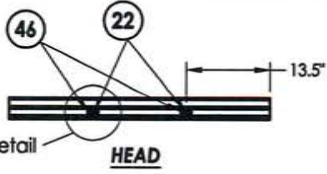

**LOCK JAMB**  
 Single Point Lock  
 (Jamb Sides Horizontal Awning)

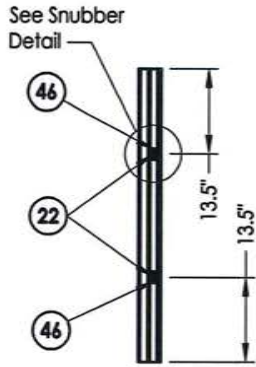
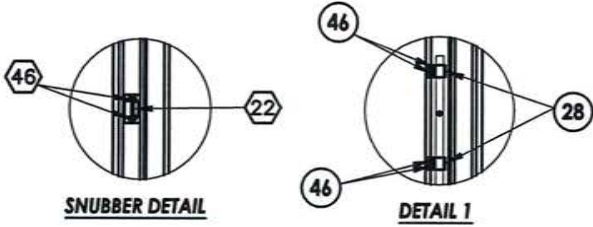

**SNUBBER JAMB**  
 (Casement)

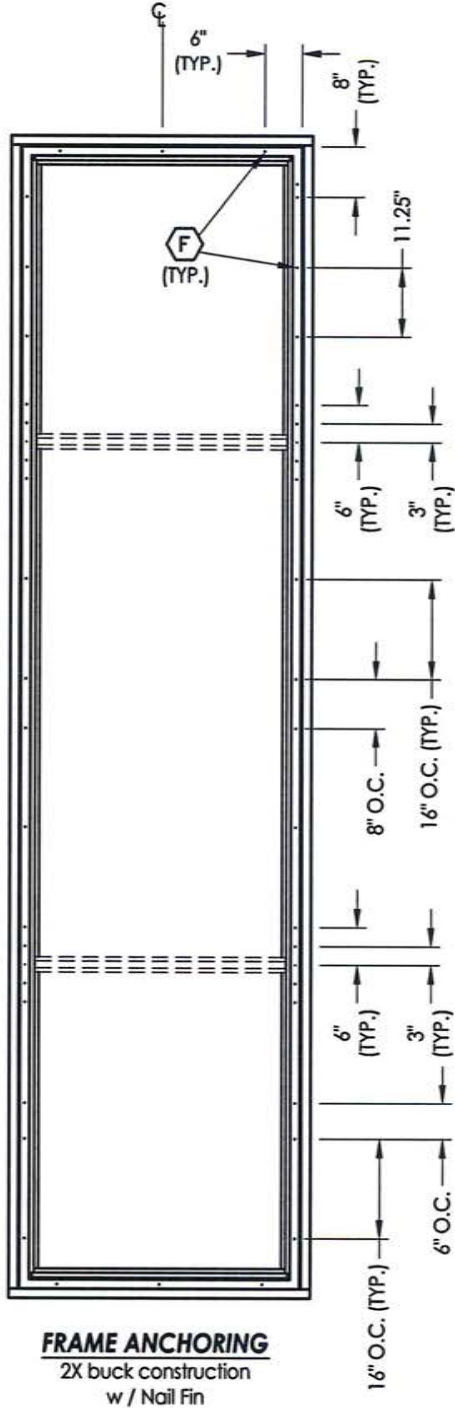

**FRAME ANCHORING**  
 2X buck construction  
 w / Nail Fin

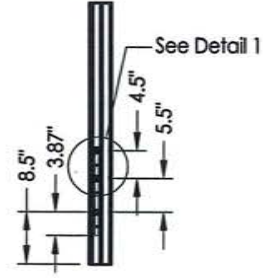

**LOCK JAMB**  
 Single Point Lock  
 (Jamb Sides Horizontal Awning)

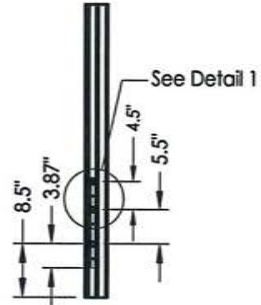

**LOCK JAMB**  
 Two Point Lock  
 (Casement)

<b>PRODUCT:</b>		FLEETWOOD KONA 3800 CASEMENT WINDOW	
<b>PART OR ASSEMBLY:</b>		FRAME ANCHORING	
NO.	DATE	REVISIONS	BY
DATE: 9/25/13			
SCALE: N.T.S.			
DWG. BY: JK			
CHK. BY: LFS			
DRAWING NO.: L-7032			
SHEET 8 OF 12			

Testing Evaluation Laboratories Inc  
 Specimen Complies with *ASTM E 2130*  
 Deviation Method - TEL # *019990814*  
 Date *10/31/13* Verified by *JLW*

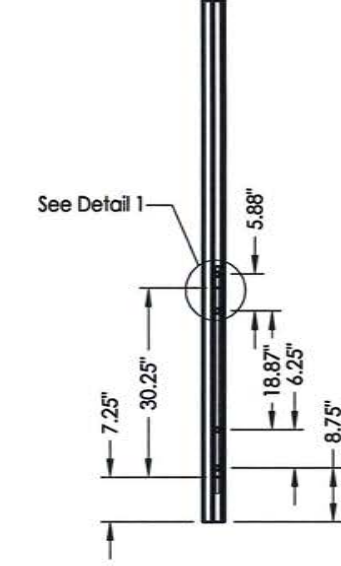
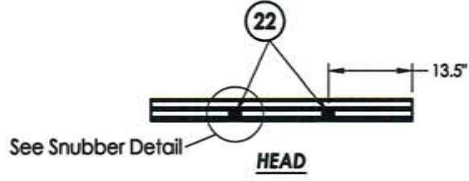

**LOCK JAMB**  
 Two Point Lock  
 (Casement)

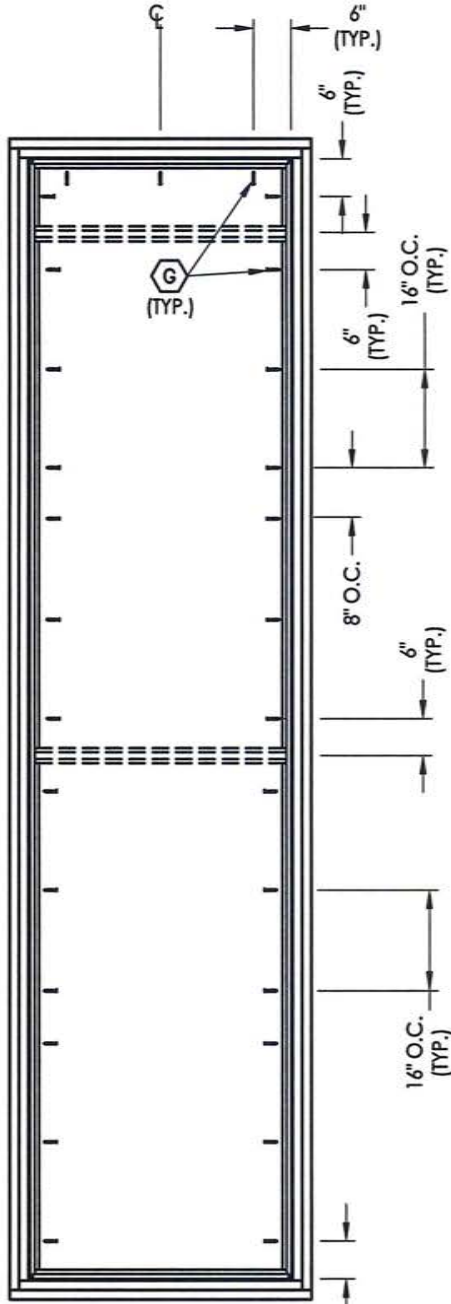
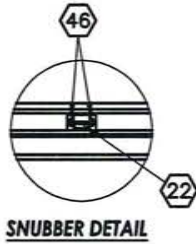

**FRAME ANCHORING**  
 2X buck construction

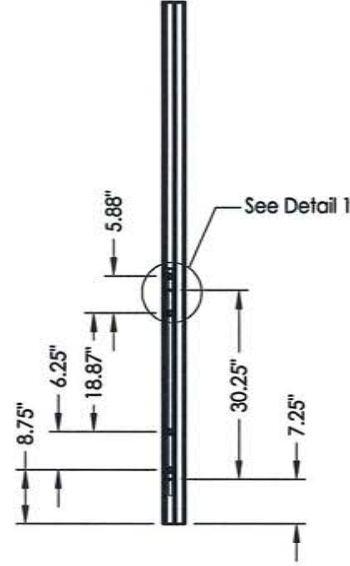

**LOCK JAMB**  
 Two Point Lock  
 (Casement)

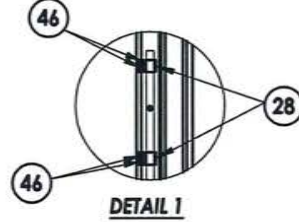

<b>PRODUCT:</b>		FLEETWOOD KONA 3800 CASEMENT WINDOW	
<b>PART OR ASSEMBLY:</b>		FRAME ANCHORING	
<b>NO.</b>	<b>DATE</b>	<b>REVISIONS</b>	<b>BY</b>
 RW BUILDING CONSULTANTS, INC. 813.659.9197			
<b>DATE:</b> 9/25/13			
<b>SCALE:</b> N.T.S.			
<b>DWG. BY:</b> JK			
<b>CHK. BY:</b> LFS			
<b>DRAWING NO.:</b> L-7032			
<b>SHEET</b> 9 <b>OF</b> 12			

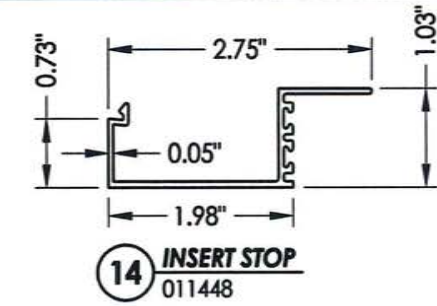

**14** INSERT STOP  
011448

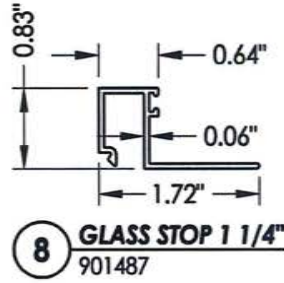

**8** GLASS STOP 1 1/4"  
901487

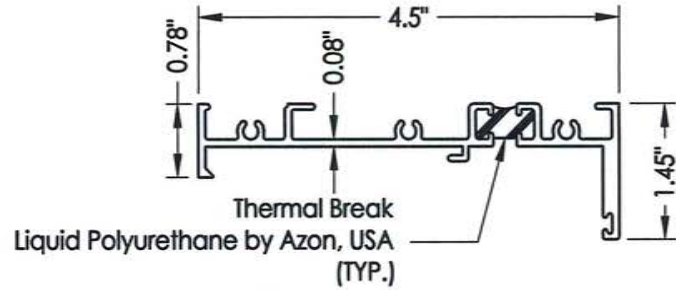

**2** KONA BLOCK FRAME  
011239

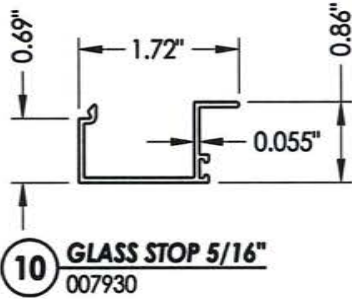

**10** GLASS STOP 5/16"  
007930

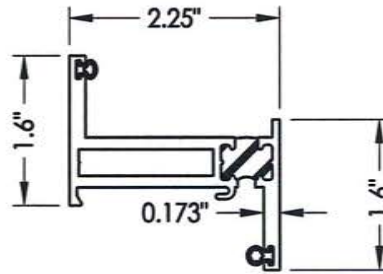

**7** ZEE BAR (PANEL)  
H006733

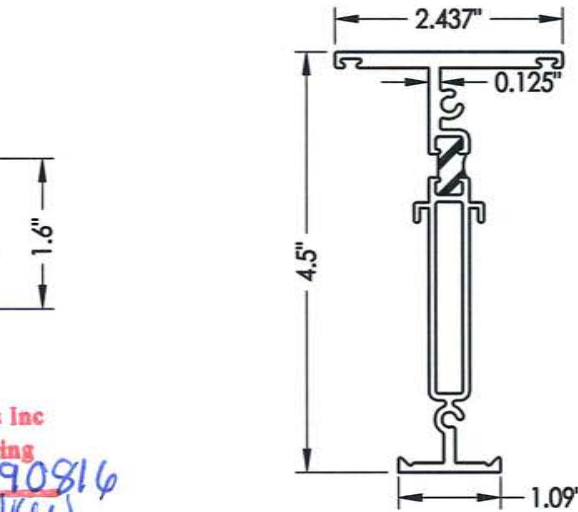

**4** MULLION  
H011241

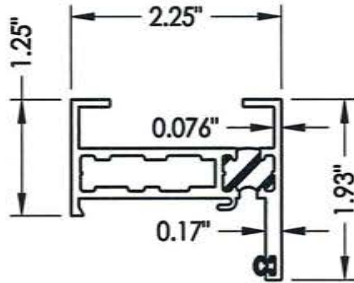

**5** BLOCK FRAME  
5278C1

Testing Evaluation Laboratories Inc  
Specimen Coraplies with Drawing  
Deviations Noted - TEL # 01990816  
Date 10/31/13 Verified by *eww*

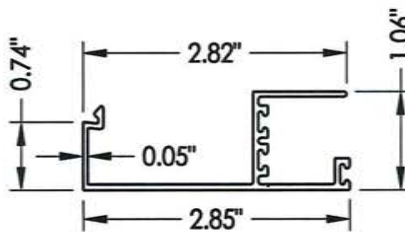

**3** GLASS STOP 1-1/4"  
011448

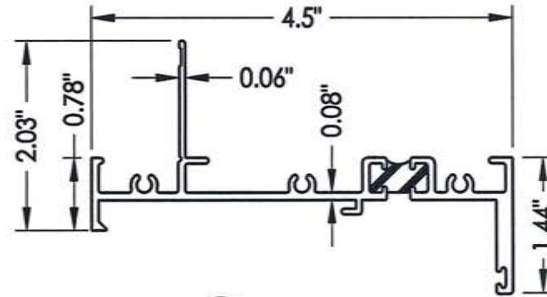

**1** KONA FIN FRAME  
011239

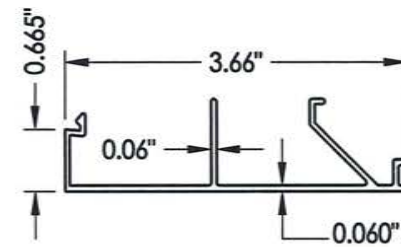

**11** GLASS STOP 5/16"  
011243

PRODUCT:		FLEETWOOD KONA 3800 CASEMENT WINDOW	
PART OR ASSEMBLY:		COMPONENTS	
NO.	DATE	REVISIONS	BY
 <b>RW BUILDING CONSULTANTS, INC.</b> 813.659.9197			
DATE: 9/25/13			
SCALE: N.T.S.			
DWG. BY: JK			
CHK. BY: LFS			
DRAWING NO.: L-7032			
SHEET 10 OF 12			

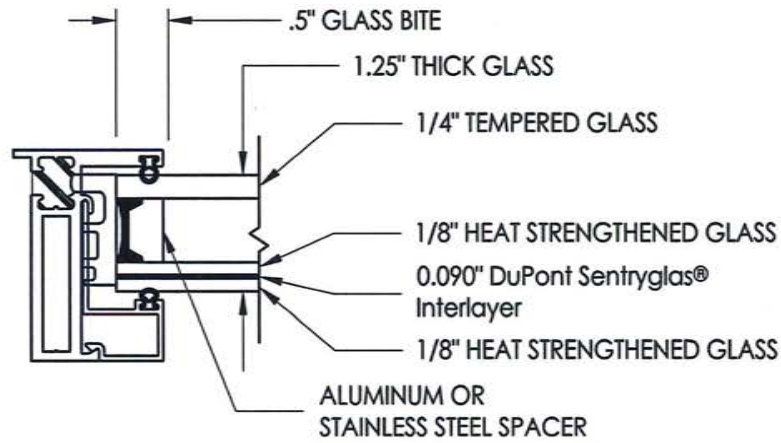
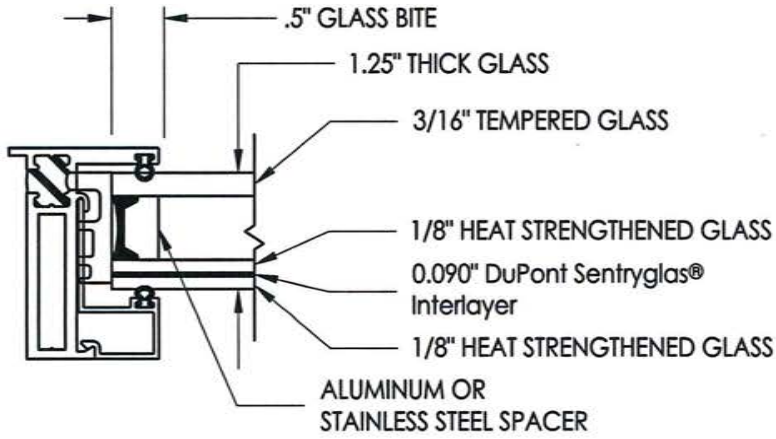
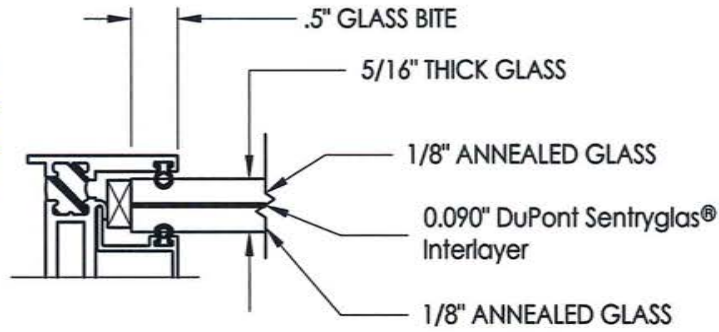
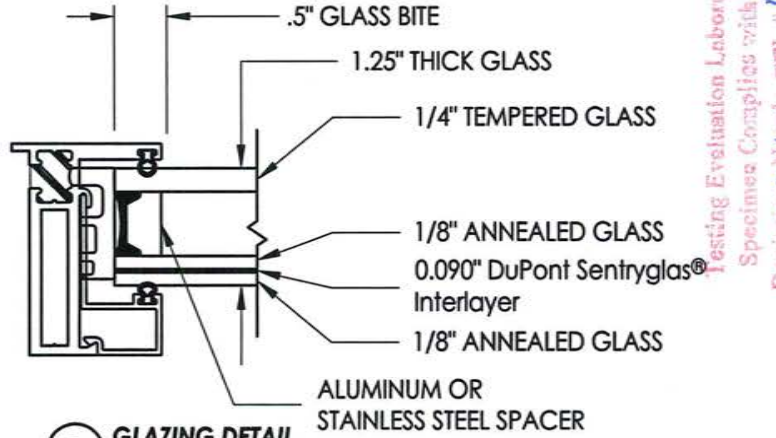

Testing Evaluation Laboratories Inc  
 Specimens Complies with Drawing  
 Deviation Noted - TEL # 01990814  
 Date 10/31/13 Verified by JKW

PRODUCT:		FLEETWOOD KONA 3800 CASEMENT WINDOW	
PART OR ASSEMBLY:		GLAZING DETAILS	
NO.	DATE	BY	REVISIONS
DATE: 9/25/13			
SCALE: N.T.S.			
DWG. BY: JK			
CHK. BY: LFS			
DRAWING NO.: L-7032			
SHEET 11 OF 12			

BILL OF MATERIALS		
ITEM #	DESCRIPTION	MATERIAL
B	2X BUCK SG >= 0.55	WOOD
C	1/4" MAX. SHIM SPACE	-
F	#10 x 1-1/2" PFH WOOD SCREW	STEEL
G	#10 x 2" PFH WOOD SCREW	STEEL
1	KONA FIN FRAME	6063-T6 ALUM
2	KONA BLOCK FRAME	6063-T6 ALUM
3	GLASS STOP 1 1/4"	6063-T6 ALUM
4	MULLION	6063-T6 ALUM
5	WESTWOOD BLOCK FRAME	6063-T6 ALUM
7	WESTWOOD ZEE BAR (PANEL)	6063-T6 ALUM
8	GLASS STOP 1 1/4"	6063-T6 ALUM
10	GLASS STOP 1/2"	6063-T6 ALUM
11	GLASS STOP 5/8"	6063-T6 ALUM
12	SHEAR BLOCK	ALUM
13	CORNER KEY	ALUM
14	INSERT STOP	ALUM
20	SS. BUTT HINGE	SS
21	4 BAR HINGE	SS
22	SNUBBER-COMMERCIAL PULL-IN BLOCK	ZINC ALLOY
23	MULTIPOINT LOCK HANDLE	SS
24	SINGLE POINT LOCKING BAR	SS
25	2 POINTS LOCKING BAR	SS
28	TIE BAR GUIDE	PLASTIC
29	KEEPER	SS
30	CASEMENT ROTOR GEAR 13.5"	SS
35	CAM HANDLE / STRIKE PLATE	SS
36	CASEMENT SS. TRACK	SS
37	AWNING SS. TRACK	SS
40	#10 X 1" PPH SMS	STEEL
42	MACHINE SCREW NO 10-32, FHP .75"	STEEL
43	SCREW NO 10 , UFHP .5"	STEEL
44	SCREW NO 8, PHP, .50"	STEEL

46	SCREW NO 8, FHP, .750"	STEEL
47	MACHINE SCREW NO 10-32, PHP .5"	STEEL
48	BACK UP NUTS	STEEL
50	BULB VINYL (EPDM 70 DUROMETER)-TREMCO	-
51	MINI BULB VINYL(EPDM 70 DUROMETER)-TREMCO	-
52	WOOD BLOCK .750" X 1.250"	-
53	ALUMINUM BLOCK .750" X 1.250"	-
54	PVC BLOCK .750" X 1.250"	-
55	SETTING BLOCK	-
56	SETTING BLOCK 4" x 1/4" x 1"	-
57	PIVOT SHIM	-
58	WOOD BLOCK .50" X 1.250"	-
59	ALUMINUM BLOCK .50" X 1.250"	-
60	PVC BLOCK .50" X 1.250"	-
61	SETTING BLOCK 4" x 1/8" x 1"	-

Testing Evaluation Laboratories Inc  
 Specimen Complies with Drawing  
 Deviations Noted - TEL # 01990816  
 Date 10/31/13 Verified by Uluw

PRODUCT:		FLEETWOOD KONA 3800 CASEMENT WINDOW	
PART OR ASSEMBLY:		BILL OF MATERIALS	
NO.	DATE	BY	REVISIONS
 RW BUILDING CONSULTANTS, INC. 813.659.9197			
DATE: 9/25/13			
SCALE: N.T.S.			
DWG. BY: JK			
CHK. BY: LFS			
DRAWING NO.: L-7032			
SHEET 12 OF 12			



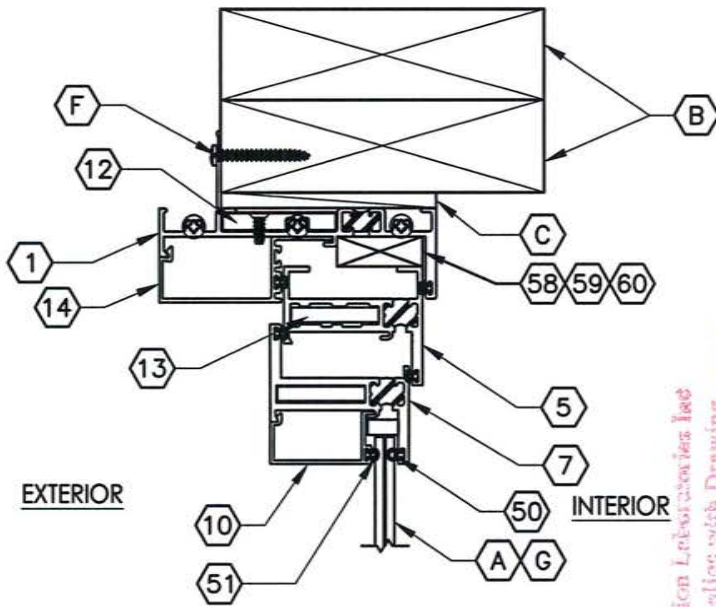

**1**  
**2** VERTICAL CROSS SECTION

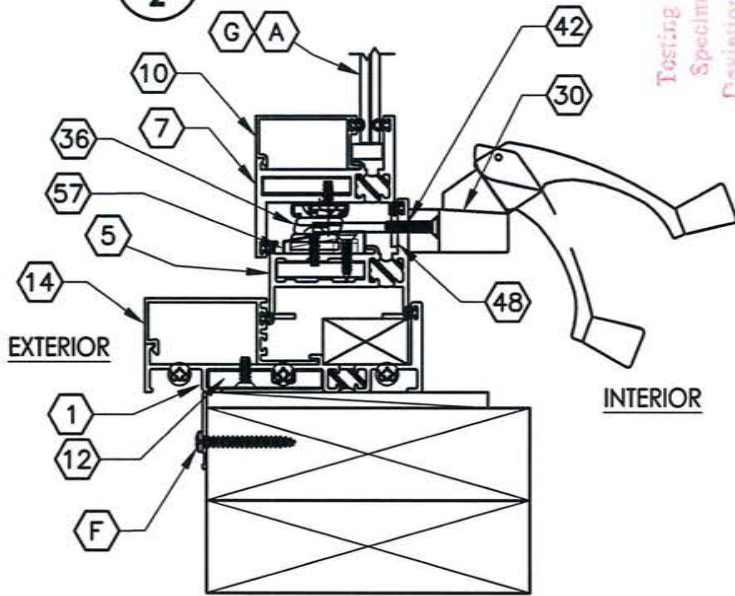

**2**  
**2** VERTICAL CROSS SECTION

Testing Evaluation Laboratories Inc  
 Specimen Complies with Drawing  
 Deviation Noted - TEL # 019990816  
 Date 10/14/13 Verified by JWC

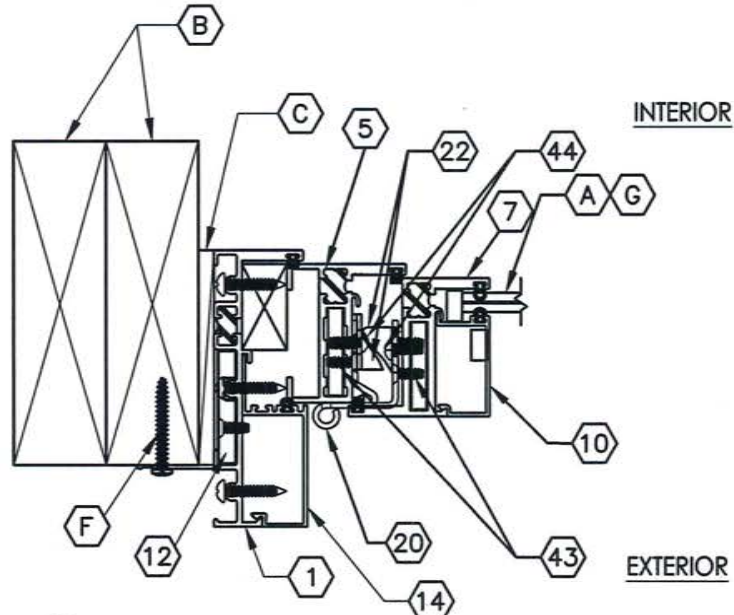

**3**  
**2** HORIZONTAL CROSS SECTION

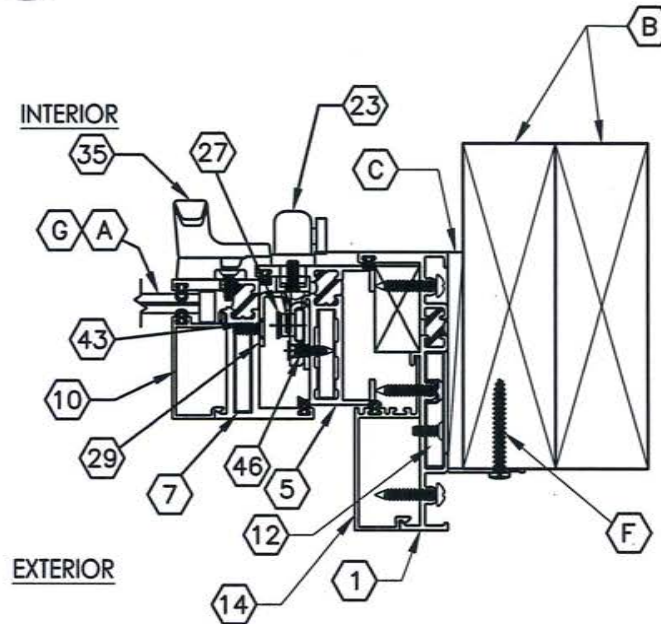

**4**  
**2** HORIZONTAL CROSS SECTION

PRODUCT:		FLEETWOOD KONA 3800 CASEMENT WINDOW	
PART OR ASSEMBLY:		HORIZONTAL AND VERTICAL CROSS SECTIONS	
NO.	DATE	BY	REVISIONS
 RW BUILDING CONSULTANTS, INC. 813.659.9197			
DATE: 9/25/13			
SCALE: N.T.S.			
DWG. BY: JK			
CHK. BY: LFS			
DRAWING NO.: L-7032A			
SHEET 2 OF 5			



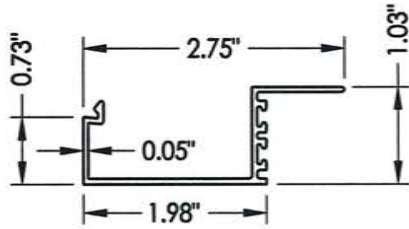

**14** **INSERT STOP**  
011448

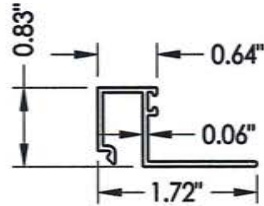

**8** **GLASS STOP 1-1/4"**  
901487

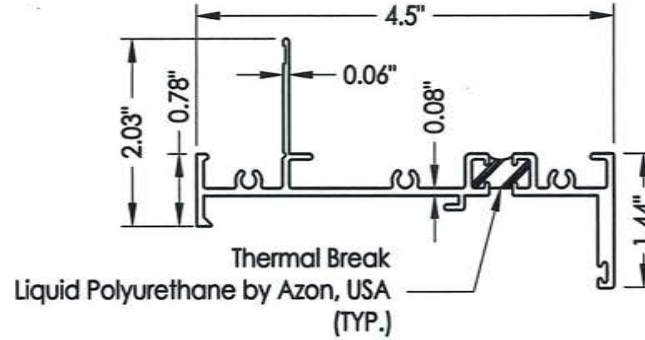

**1** **KONA FIN FRAME**  
011239

Testing Evaluation Laboratories Inc  
Specimen Complies with Drawing  
Deviations Noted - TEL # 01990816  
Date 10/31/13 Verified by WJL

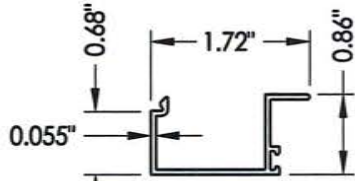

**10** **GLASS STOP 9/16"**  
007930

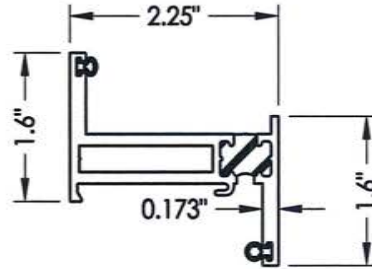

**7** **ZEE BAR (PANEL)**  
H006733

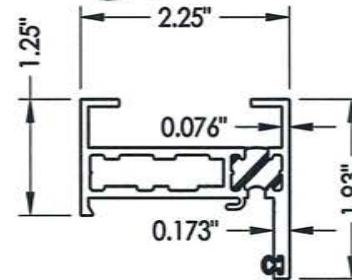

**5** **BLOCK FRAME**  
5278C1

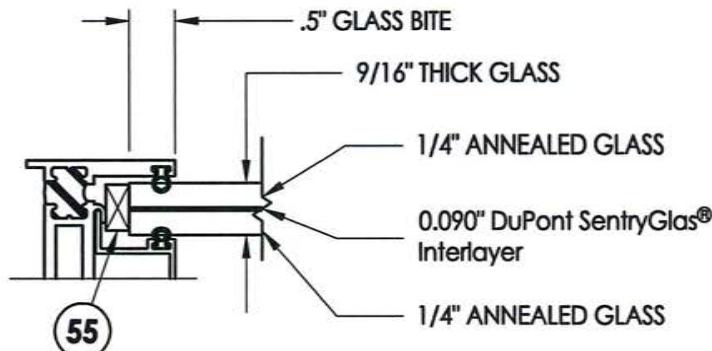

**G** **GLAZING DETAIL**  
Spec #5, 5A

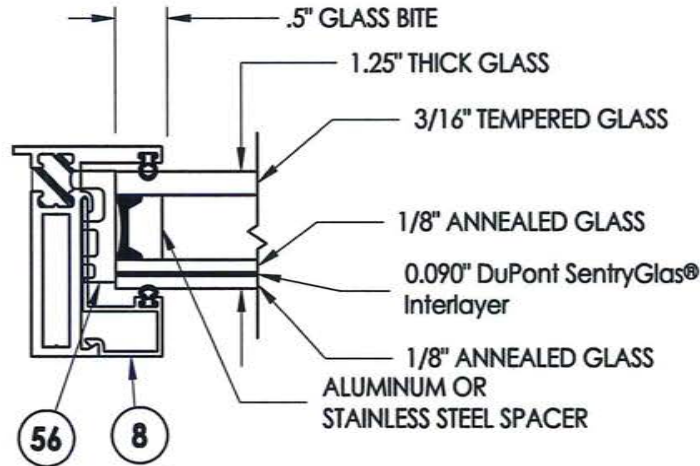

**A** **GLAZING DETAIL**  
Spec. #2, 2A

PRODUCT:		FLEETWOOD KONA 3800 CASEMENT WINDOW	
PART OR ASSEMBLY:		COMPONENTS AND GLAZING DETAILS	
NO.	DATE	BY	REVISIONS
DATE: 9/25/13			
SCALE: N.T.S.			
DWG. BY: JK			
CHK. BY: LFS			
DRAWING NO.: L-7032A			
SHEET 4 OF 5			



TABLE OF CONTENTS	
SHEET #	DESCRIPTION
1	Table of contents
2	Test elevation
3	Horizontal and vertical cross sections
4	Horizontal and vertical cross sections
5	Frame anchoring
6	Frame anchoring
7	Components
8	Glazing details
9	Bill of materials

Testing Evaluation Laboratories Inc  
 Specimen Complies with Drawing  
 Deviating Note - TEL # 01990816  
 Date 10/31/13 Verified by *WJW*

<b>PRODUCT:</b> FLEETWOOD KONA 3800 CASEMENT WINDOW	
<b>PART OR ASSEMBLY:</b> TABLE OF CONTENTS	
REVISIONS	
NO.	DATE
BY	BY



DATE: 9/25/13  
 SCALE: N.T.S.  
 DWG. BY: JK  
 CHK. BY: LFS  
 DRAWING NO.:  
 L-7033  
 SHEET 1 OF 9

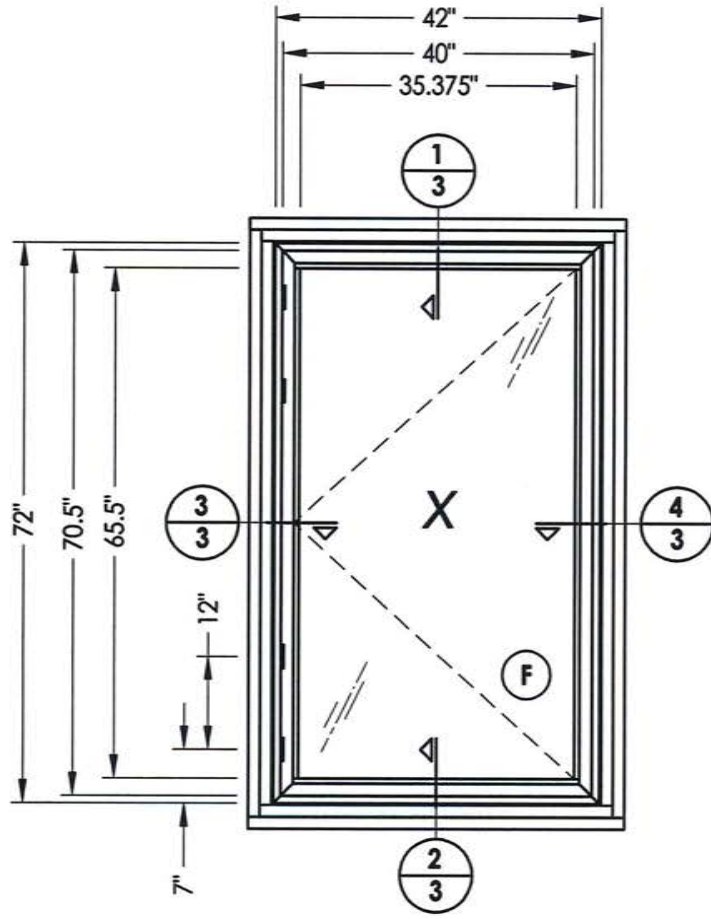

**SPEC# 12, 12A**

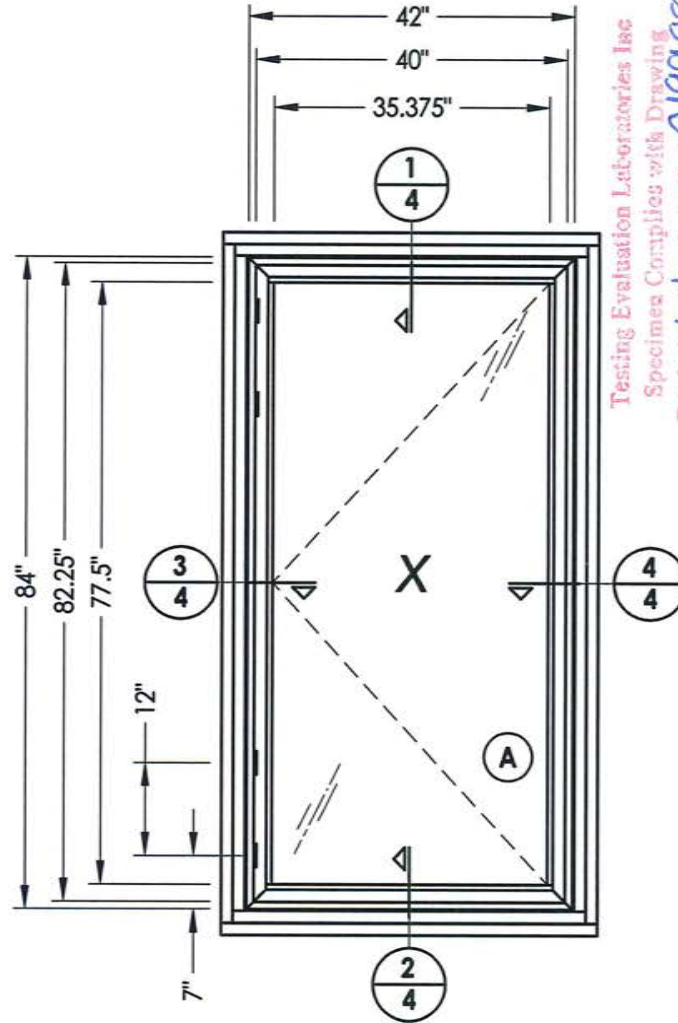

**SPEC# 6, 6A**

Testing Evaluation Laboratories Inc  
 Specimen Complies with Drawing  
 Deviation Noted - TEL # 01990816  
 Date: 10/31/13 Verified by: WJG

<b>PRODUCT:</b> FLEETWOOD KONA 3800 CASEMENT WINDOW		
<b>PART OR ASSEMBLY:</b> TEST ELEVATION		
NO.	DATE	BY
REVISIONS		
RW BUILDING CONSULTANTS, INC. 813.659.9197		
<b>DATE:</b> 9/25/13		
<b>SCALE:</b> N.T.S.		
<b>DWG. BY:</b> JK		
<b>CHK. BY:</b> LFS		
<b>DRAWING NO.:</b> L-7033		
SHEET <u>2</u> OF <u>9</u>		

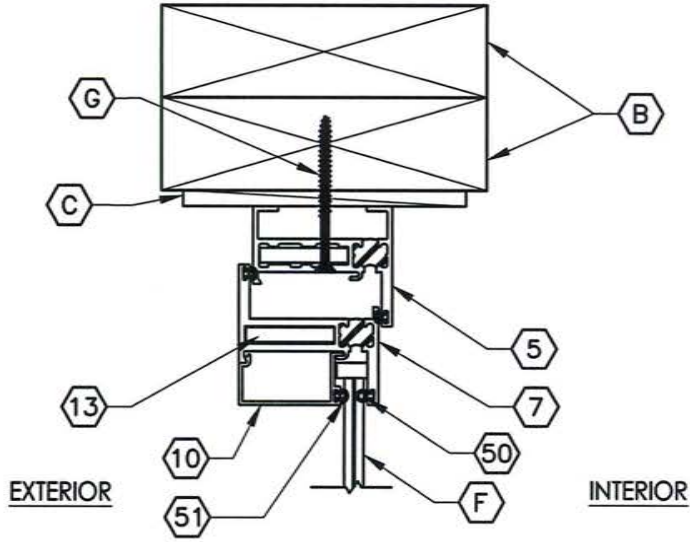

**1**  
**3** VERTICAL CROSS SECTION

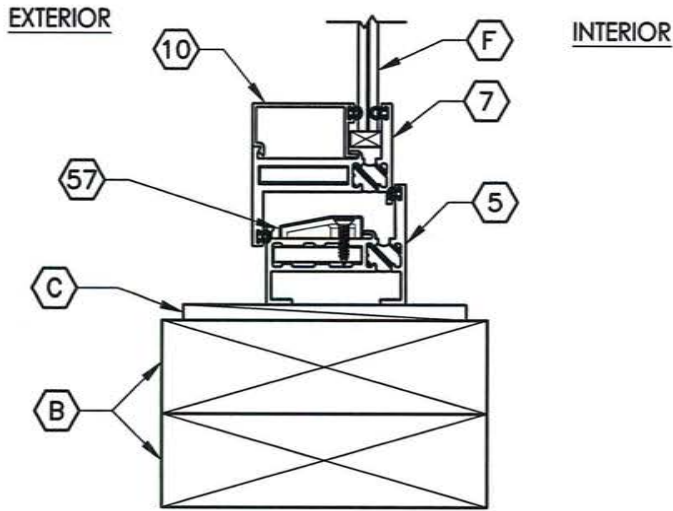

**2**  
**3** VERTICAL CROSS SECTION

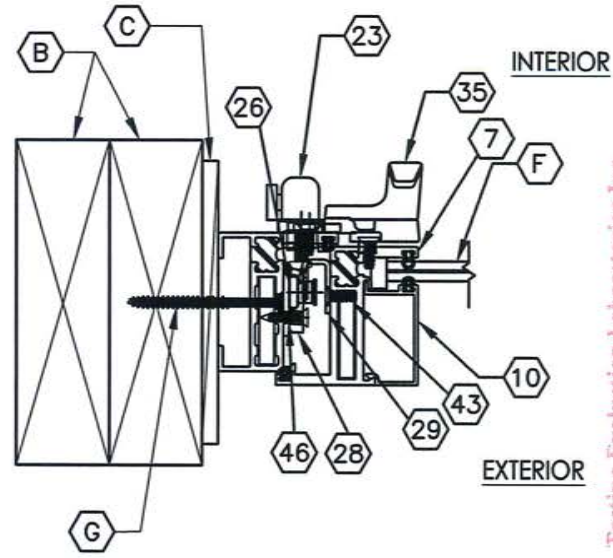

**3**  
**3** HORIZONTAL CROSS SECTION

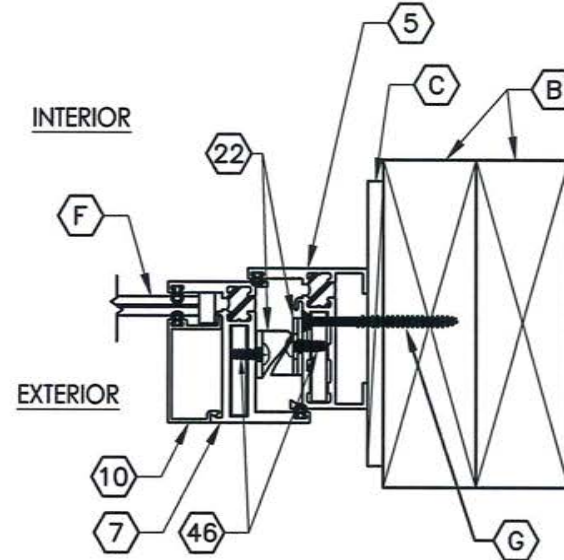

**4**  
**3** HORIZONTAL CROSS SECTION

Testing Evaluation Laboratories Inc  
 Specimen Complies with Drawing  
 Deviation Noted - TEL # 01990816  
 Date 10/31/12 Verified by WJL

PRODUCT:		FLEETWOOD KONA 3800 CASEMENT WINDOW	
PART OR ASSEMBLY:		HORIZONTAL AND VERTICAL CROSS SECTIONS	
NO.	DATE	BY	REVISIONS
DATE: 9/25/13			
SCALE: N.T.S.			
DWG. BY: JK			
CHK. BY: LFS			
DRAWING NO.: L-7033			
SHEET 3 OF 9			

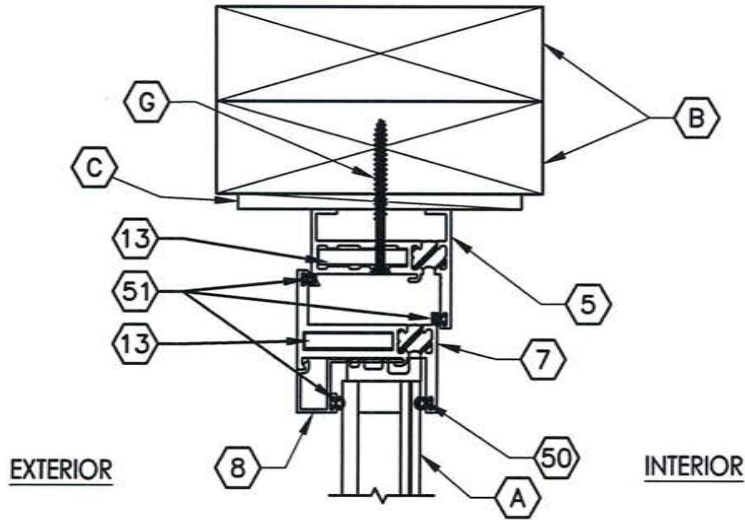

**1**  
**4** VERTICAL CROSS SECTION

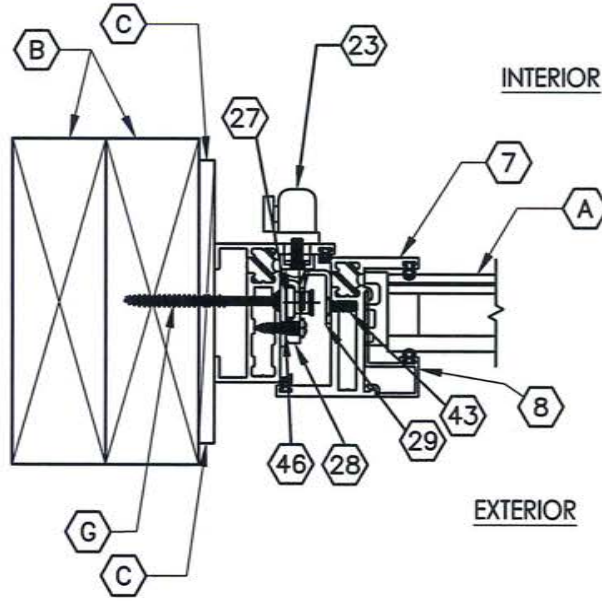

**3**  
**4** HORIZONTAL CROSS SECTION

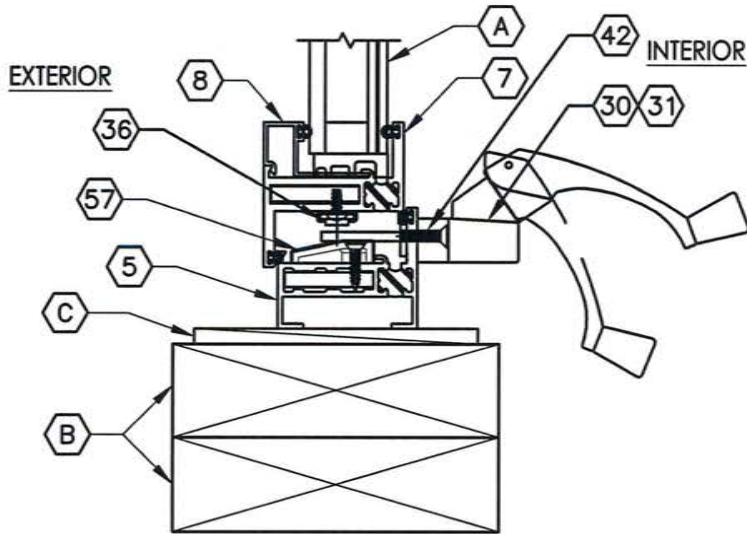

**2**  
**4** VERTICAL CROSS SECTION

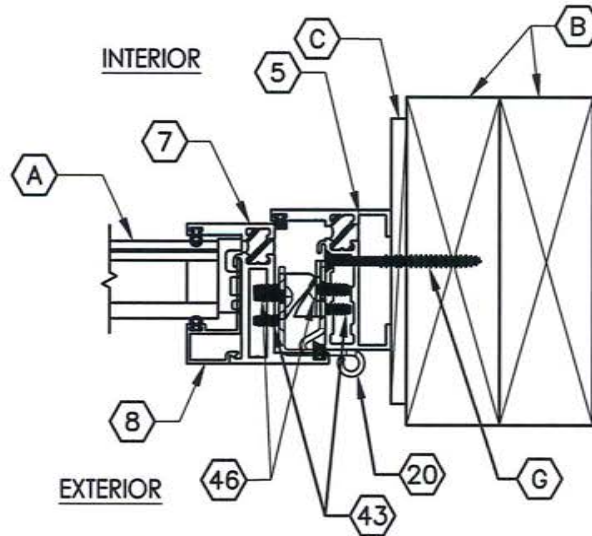

**4**  
**4** HORIZONTAL CROSS SECTION

Testing Evaluation Laboratories Inc  
 Specimen: Complies with Drawing  
 Deviation: None - TEL # 0199.0814  
 Date: 10/31/13 / certified by ulkw

PRODUCT:		FLEETWOOD KONA 3800 CASEMENT WINDOW	
PART OR ASSEMBLY:		HORIZONTAL AND VERTICAL CROSS SECTIONS	
NO.	DATE	BY	REVISIONS
 RW BUILDING CONSULTANTS, INC. 813.659.9197			
DATE: 9/25/13			
SCALE: N.T.S.			
DWG. BY: JK			
CHK. BY: LFS			
DRAWING NO.: L-7033			
SHEET 4 OF 9			

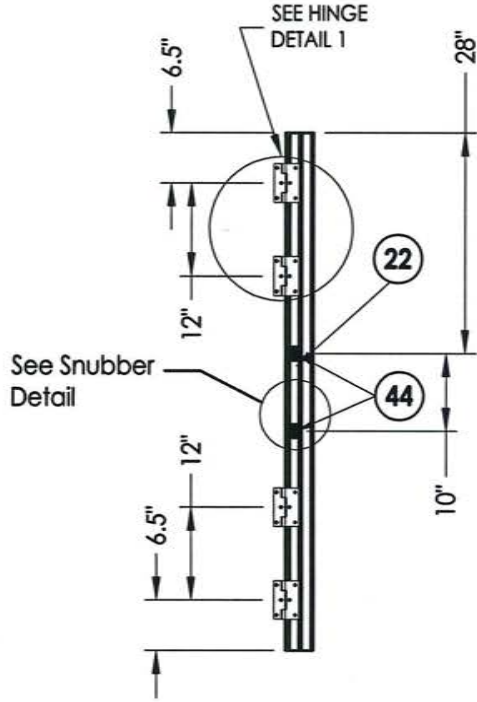

**SNUBBER JAMB**

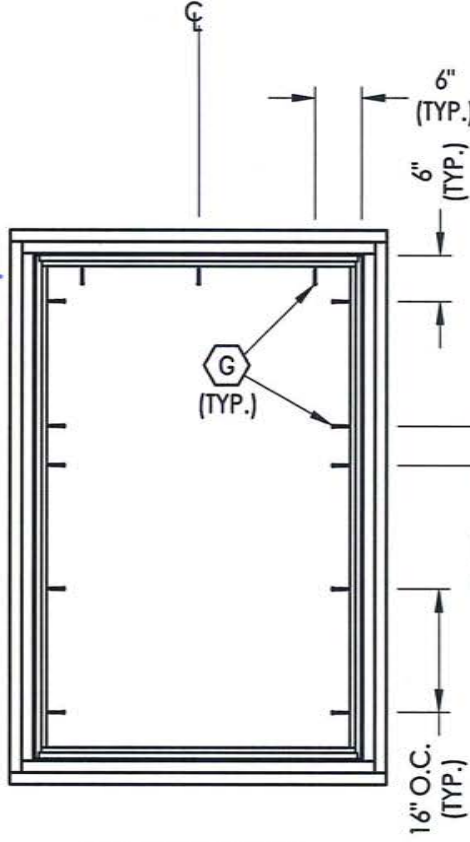

**FRAME ANCHORING**  
2X buck construction

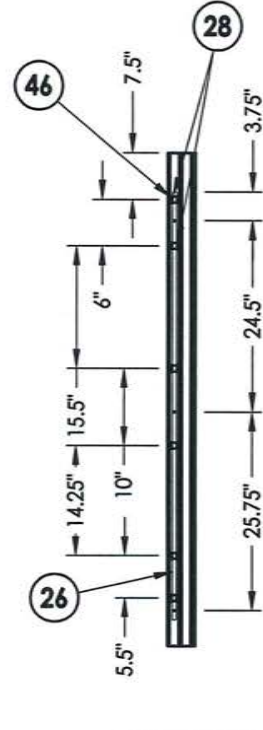

**LOCK JAMB**  
Locking Points (3)

Testing Evaluation Laboratories Inc  
Specimens Complies with Drawing  
Deviation Number - TEL # 01990814  
Date 10/31/13 verified by Steve

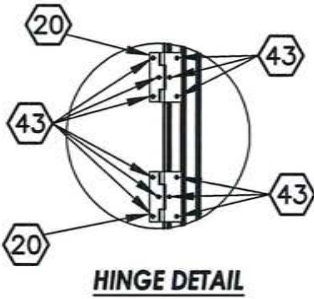

**HINGE DETAIL**



**SNUBBER DETAIL**

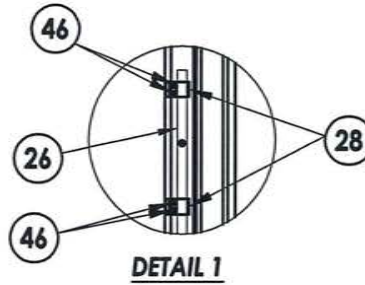

**DETAIL 1**

<b>PRODUCT:</b>		FLEETWOOD KONA 3800 CASEMENT WINDOW	
<b>PART OR ASSEMBLY:</b>		FRAME ANCHORING	
NO.	DATE	REVISIONS	BY
DATE: 9/25/13			
SCALE: N.T.S.			
DWG. BY: JK			
CHK. BY: LFS			
DRAWING NO.: L-7033			
SHEET 5 OF 9			

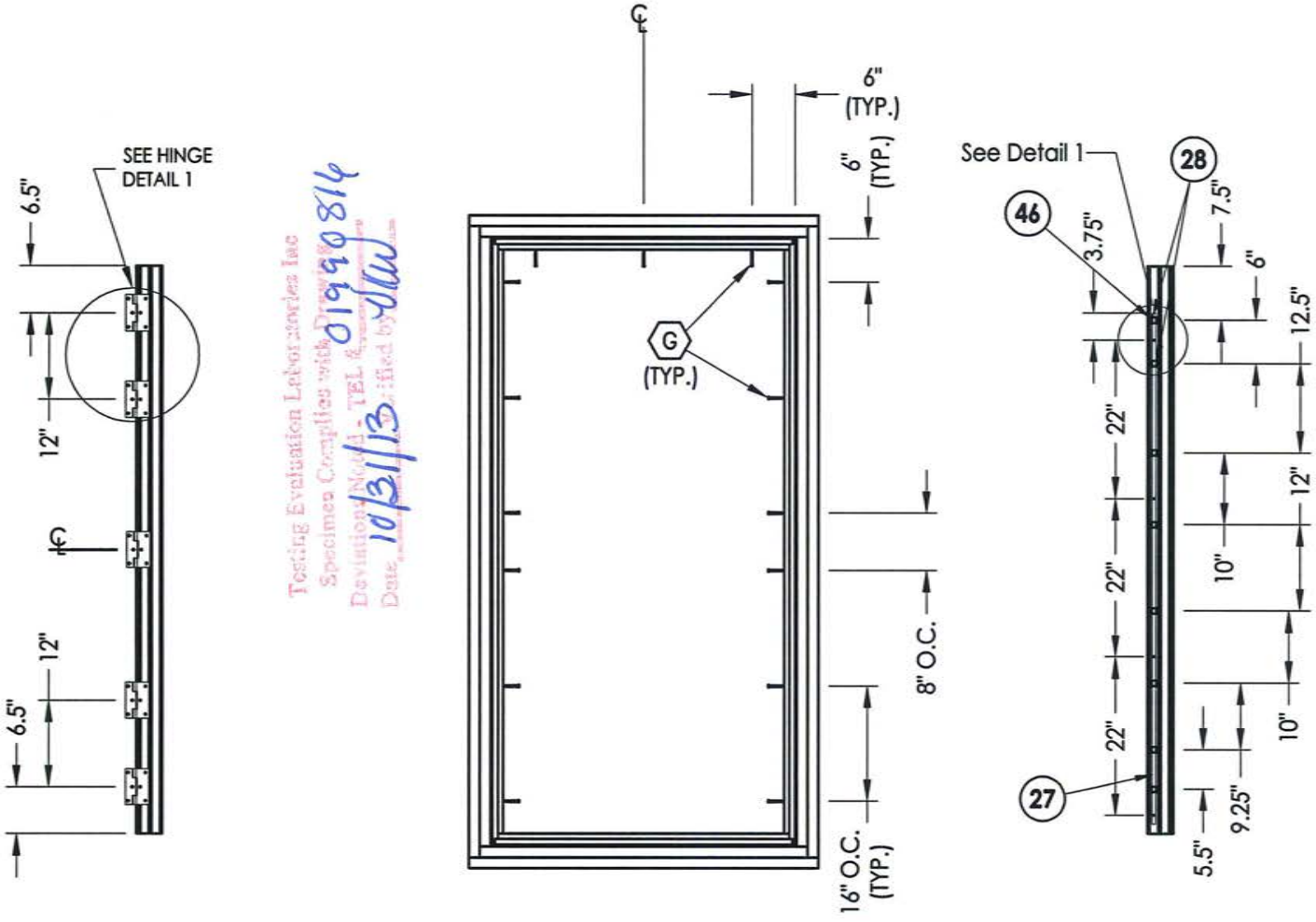

Testing Evaluation Laboratories Inc  
 Specimen Complies with Drawings  
 Deviation No. A. TEL: 800-888-8888  
 Date: 10/31/13  
 Certified by: dlw

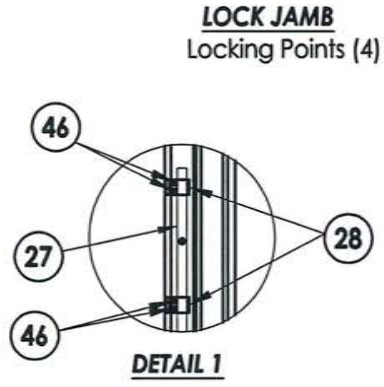
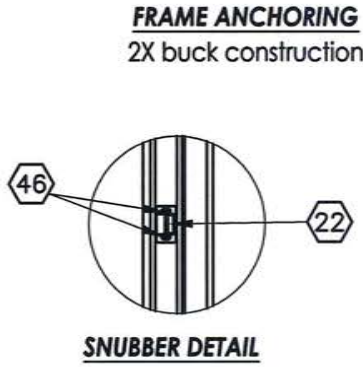
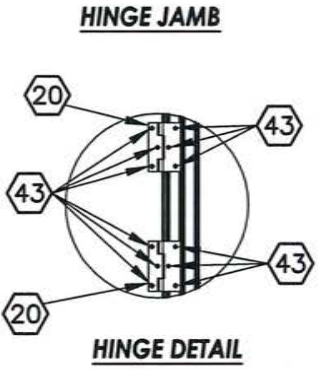

PRODUCT:		FLEETWOOD KONA 3800 CASEMENT WINDOW	
PART OR ASSEMBLY:		FRAME ANCHORING	
NO.	DATE	REVISIONS	BY
RW BUILDING CONSULTANTS, INC. 813.659.9197			
DATE: 9/25/13			
SCALE: N.T.S.			
DWG. BY: JK			
CHK. BY: LFS			
DRAWING NO.: L-7033			
SHEET 6 OF 9			

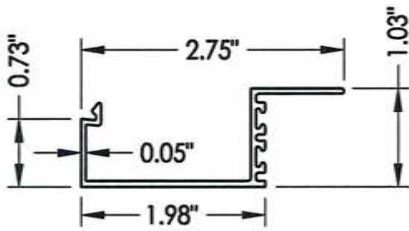

**14 INSERT STOP**  
011448

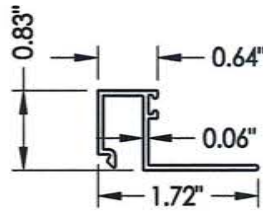

**8 GLASS STOP 1-1/4"**  
901487

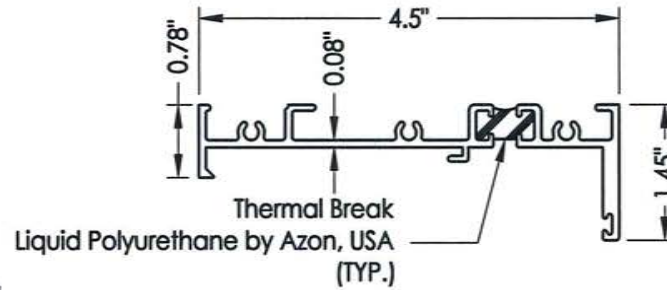

**2 KONA BLOCK FRAME**  
011239

Testing Evaluation Laboratories Inc  
 Specimen Complies with Drawing  
 Deviations Noted - TEL # 01990816  
 Date 10/31/13 Verified by JKW

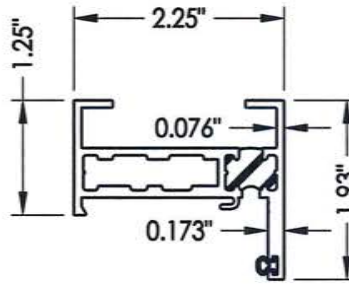

**5 BLOCK FRAME**  
5278C1

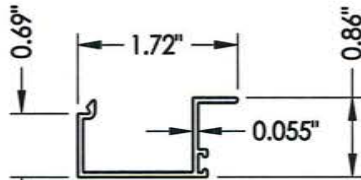

**10 GLASS STOP 5/16", 7/16"**  
007930

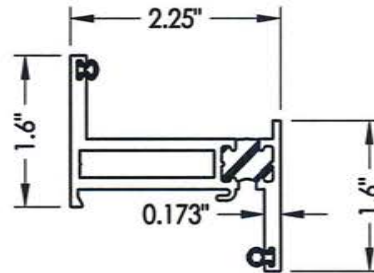

**7 ZEE BAR (PANEL)**  
H006733

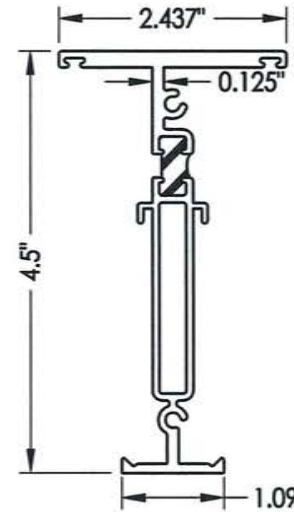

**4 MULLION**  
H011241

PRODUCT:		FLEETWOOD KONA 3800 CASEMENT WINDOW	
PART OR ASSEMBLY:		COMPONENTS	
NO.	DATE	BY	REVISIONS
 RW BUILDING CONSULTANTS, INC. 813.659.9197			
DATE: 9/25/13			
SCALE: N.T.S.			
DWG. BY: JK			
CHK. BY: LFS			
DRAWING NO.: L-7033			
SHEET 7 OF 9			

Testing Evaluation Laboratories Inc  
 Specimens Complies with Drawing  
 Deviation Noted - TEL # 01990814  
 Date 11/13/13 Verified by JFCW

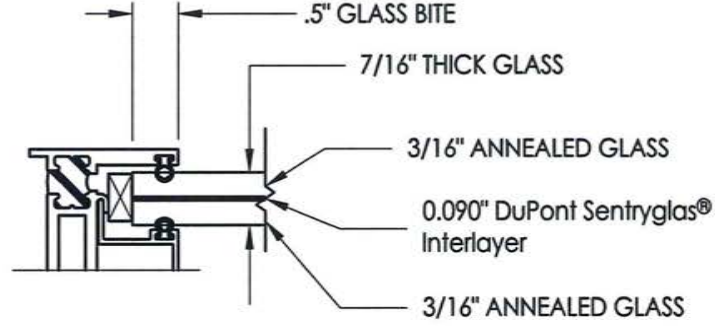
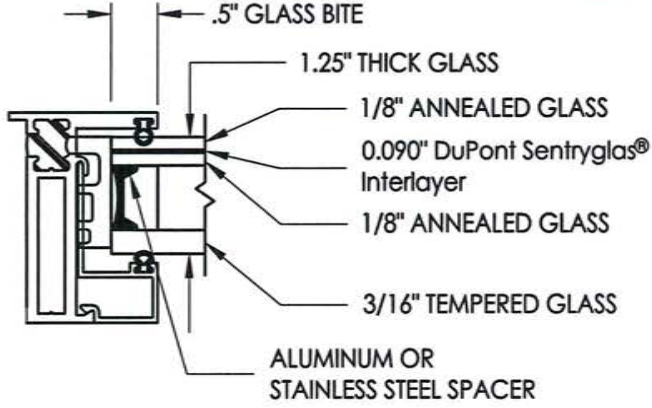

PRODUCT:		FLEETWOOD KONA 3800 CASEMENT WINDOW	
PART OR ASSEMBLY:		COMPONENTS AND GLAZING DETAILS	
NO.	DATE	REVISIONS	BY
DATE: 9/25/13			
SCALE: N.T.S.			
DWG. BY: JK			
CHK. BY: LFS			
DRAWING NO.: L-7033			
SHEET 8 OF 9			

BILL OF MATERIALS		
ITEM #	DESCRIPTION	MATERIAL
B	2X BUCK SG >= 0.55	WOOD
C	1/4" MAX. SHIM SPACE	-
G	#10 x 2" PFH WOOD SCREW	STEEL
2	KONA BLOCK FRAME	6063-T6 ALUM
4	MULLION	6063-T6 ALUM
5	WESTWOOD BLOCK FRAME	6063-T6 ALUM
7	WESTWOOD ZEE BAR (PANEL)	6063-T6 ALUM
8	GLASS STOP (1-1/4")	6063-T6 ALUM
10	GLASS STOP (7/16")	6063-T6 ALUM
13	CORNER KEY	ALUM
14	INSERT STOP	ALUM
20	SS. BUTT HINGE	SS
21	4 BAR HINGE	SS
22	SNUBBER	ZINC ALLOY
23	MULTIPOINT LOCK HANDLE	SS
26	3 POINTS LOCKING BAR	SS
27	4 POINTS LOCKING BAR	SS
28	TIE BAR GUIDE	PLASTIC
29	KEEPER	SS
30	CASEMENT ROTOR GEAR 13.5"	SS
35	CAM HANDLE / STRIKE PLATE	SS
36	CASEMENT SS. TRACK	SS
40	#10 X 1" PPH SMS	STEEL
42	MACHINE SCREW NO 10-32, FHP .75"	STEEL
43	SCREW NO 10 , UFHP .5"	STEEL
44	SCREW NO 8, PHP, .50"	STEEL
46	SCREW NO 8, FHP, .750"	STEEL
47	MACHINE SCREW NO 10-32, PHP .5"	STEEL
48	BACK UP NUTS	STEEL
50	BULB VINYL (EPDM 70 DUROMETER)-TREMCO	-

51	MINI BULB VINYL(EPDM 70 DUROMETER)-TREMCO	-
52	WOOD BLOCK .750" X 1.250"	-
53	ALUMINUM BLOCK .750" X 1.250"	-
54	PVC BLOCK .750" X 1.250"	-
55	SETTING BLOCK	-
56	SETTING BLOCK 4" x 1/4" x 1"	-
57	PIVOT SHIM	-
58	WOOD BLOCK .50" X 1.250"	-
59	ALUMINUM BLOCK .50" X 1.250"	-
60	PVC BLOCK .50" X 1.250"	-
61	SETTING BLOCK 4" x 1/8" x 1"	-

Testing Evaluation Laboratories Inc  
 Specimens Complies with DPM 101  
 Deviation Noted - TEL: 409-90816  
 Date: 10/31/13  
 Verified by: WMO

PRODUCT:		FLEETWOOD KONA 3800 CASEMENT WINDOW	
PART OR ASSEMBLY:		BILL OF MATERIALS	
NO.	DATE	BY	REVISIONS
			
DATE: 9/25/13			
SCALE: N.T.S.			
DWG. BY: JK			
CHK. BY: LFS			
DRAWING NO.: L-7033			
SHEET 9 OF 9			