



Testing Evaluation Laboratories, Inc.

2002 Wood Court Suite 1 – Plant City, FL 33563
Phone: 813-754-9887

ASTM E 1886-05 / ASTM E 1996-09
Missile Level "D" (Includes Wind Zone 4)

TEST REPORT SUMMARY

Test Report Issued To:

Fleetwood Windows and Doors
1 Fleetwood Way
Corona, CA 92879

3900-T Side Hinged Doors

Title of Test	Results			
	Specimen 8a 48.00 x 120.00 X - Outswing	Specimen 12a 48.00 x 120.00 X - Outswing	Specimens 12 ALT – a, b, c 48.00 x 120.00 X - Outswing	Specimen 15a 48.00 x 120.00 X - Outswing
Impact	Pass	Pass	Pass	Pass
Fatigue Load Cycling	+65.0/- 65.0 psf	+65.0/- 65.0 psf	+65.0/- 65.0 psf	+65.0/- 65.0 psf

Reference should be made to Report No. TEL 01991342 for complete test specimen description and data. For corresponding data regarding AAMA/WDMA/CSA 101/I.S./2/A440-08 and A440-11 (A440S1-09) reference should be made to Report Nos. TEL 01991337, 01991338, 01991339 and 01991341.

For Testing Evaluation Laboratories, Inc.

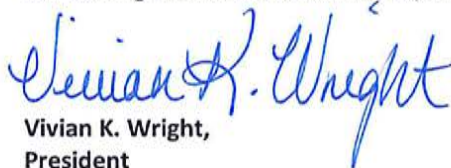
Vivian K. Wright,
President



Testing Evaluation Laboratories, Inc.

2002 Wood Court Suite 1 – Plant City, FL 33563
Phone: 813-754-9887

TEST RESULTS

IAS Lab Certification Number: TL-299

Report No: TEL 01991342
Test Dates: March 16, 2015
through April 1, 2015
Report Date: June 26, 2015

Issued to:

Fleetwood Windows and Doors
1 Fleetwood Way
Corona, CA 92879

Project Summary: Testing Evaluation Laboratories, Inc. (TEL) was contracted by Fleetwood Windows and Doors to perform tests on the 3900-T Side Hinged Doors at TEL's Plant City, FL test facility.

Test specimen descriptions and results are reported herein.

Test Specifications: The test specimens were evaluated in accordance with the following:

ASTM E 1886-05 / ASTM E 1996-09
Missile Level "D" (Includes Wind Zone 4)

Test Specimen Description:

Series / Model: 3900-T Side Hinged Doors
Type: Aluminum Side Hinged Doors
Overall Size: 48.00" x 120.00" – All Specimens – (X)
Daylight Opening: 35.00" x 91.00" – Top Fixed Glass – Specimen 8a
35.00" x 14.00" – Bottom Fixed Glass – Specimen 8a
35.00" x 108.00" – Specimens 12a, 12 ALT-a, 12 ALT-b, 12 ALT-c, 15a
Glazing Details: See attached drawings for glazing details.
Frame Material: Aluminum
Finish: Mill Finish

For Tested Elevation, Vertical Cross Sections, Horizontal Cross Sections, Components, Frame Anchoring, Glazing Detail and Bill of Materials See Attached Drawing numbers L-7353, L-7343, L-7344 and L-7354.

IMPACT AND CYCLING TESTS

Specimen 8a – 48.00" x 120.00" – Outswing Door – X (w/TDL Bar)

ASTM E1886-05/1996-09 – Large Missile Impact (2 x 4 Southern Yellow Pine)

Cond. Temp Of Specimen	Missile Level	Missile Weight	Missile Length	Muzzle Distance From Specimen
75°F	D	9.0 lbs, 1 oz.	8'-1/2"	17'0"

Impact Location	Results	X - Measurement	Y - Measurement	Speed
1	Pass	24.00"	20.00"	50.1 fps
2	Pass	38.00"	27.00"	49.9 fps
3	Pass	24.00"	69.00"	50.0 fps
Orientation of Missile at Impact was within +/-5° of horizontal. None of the impacts penetrated the specimens. "X" measurement is from the left edge of test specimen. "Y" measurement is from the bottom edge of test specimen.				

ASTM E1886-05/1996-09 – Fatigue Load Cycling

Design Pressure +65.0 psf / - 65.0 psf

Positive % of Test Load	Positive Pressure Range (psf)	Number Of Cycles	Average Cycle Time (Sec)
20% to 50%	13.0 to 32.5	3500	1.67
0% to 60%	0.0 to 39.0	300	2.17
50% to 80%	32.5 to 52.0	600	1.80
30% to 100%*	19.5 to 65.0	100	2.65

Negative % of Test Load	Negative Pressure Range (psf)	Number Of Cycles	Average Cycle Time (Sec)
30% to 100%*	19.5 to 65.0	50	2.98
50% to 80%	32.5 to 52.0	1050	1.52
0% to 60%	0.0 to 39.0	50	2.41
20% to 50%	13.0 to 32.5	3350	1.71

*Active Panel deflected 1.63" from original plane at 100% Positive load and 2.50" from original plane at 100% Negative load. At the completion of cycles the door panel was operable. There were no tears in the film. In our opinion, the tape and film used to seal for air leakage did not influence the results of the test.

James Hayhurst, Test Technician

IMPACT AND CYCLING TESTS

Specimen 12a – 48.00" x 120.00" – Outswing Door – X

ASTM E1886-05/1996-09 – Large Missile Impact (2 x 4 Southern Yellow Pine)

Cond. Temp Of Specimen	Missile Level	Missile Weight	Missile Length	Muzzle Distance From Specimen
75°F	D	9.0 lbs, 1 oz.	8'-1/2"	17'0"

Impact Location	Results	X - Measurement	Y - Measurement	Speed
1	Pass	24.00"	60.00"	50.0 fps
2	Pass	44.00"	48.00"	49.9 fps
3	Pass	24.00"	3.00"	50.0 fps
4	Pass	35.00"	12.00"	50.1 fps

Orientation of Missile at Impact was within +/-5° of horizontal.
 None of the impacts penetrated the specimens.
 "X" measurement is from the left edge of test specimen.
 "Y" measurement is from the bottom edge of test specimen.

ASTM E1886-05/1996-09 – Fatigue Load Cycling
 Design Pressure +65.0 psf / - 65.0 psf

Positive % of Test Load	Positive Pressure Range (psf)	Number Of Cycles	Average Cycle Time (Sec)
20% to 50%	13.0 to 32.5	3500	1.94
0% to 60%	0.0 to 39.0	300	2.70
50% to 80%	32.5 to 52.0	600	1.75
30% to 100%*	19.5 to 65.0	100	3.00

Negative % of Test Load	Negative Pressure Range (psf)	Number Of Cycles	Average Cycle Time (Sec)
30% to 100%*	19.5 to 65.0	50	3.00
50% to 80%	32.5 to 52.0	1050	2.50
0% to 60%	0.0 to 39.0	50	2.80
20% to 50%	13.0 to 32.5	3350	2.50

*Active Panel deflected 2.25" from original plane at 100% Positive load and 3.00" from original plane at 100% Negative load. At the completion of cycles the door panel was operable. There were no tears in the film. In our opinion, the tape and film used to seal for air leakage did not influence the results of the test.

James Hayhurst, Test Technician

IMPACT AND CYCLING TESTS

Specimen 12 ALT a – 48.00" x 120.00" – Outswing Door – X

ASTM E1886-05/1996-09 – Large Missile Impact (2 x 4 Southern Yellow Pine)

Cond. Temp Of Specimen	Missile Level	Missile Weight	Missile Length	Muzzle Distance From Specimen
75°F	D	9.0 lbs, 0 oz.	8'-0"	17'0"

Impact Location	Results	X - Measurement	Y - Measurement	Speed
1	Pass	24.00"	60.00"	50.0 fps
2	Pass	36.00"	11.50"	49.7 fps
3	Pass	24.00"	3.00"	49.9 fps
4	Pass	44.25"	50.00"	50.1 fps
<p>Orientation of Missile at Impact was within +/-5° of horizontal. None of the impacts penetrated the specimens. "X" measurement is from the left edge of test specimen. "Y" measurement is from the bottom edge of test specimen.</p>				

ASTM E1886-05/1996-09 – Fatigue Load Cycling

Design Pressure +65.0 psf / - 65.0 psf

Positive % of Test Load	Positive Pressure Range (psf)	Number Of Cycles	Average Cycle Time (Sec)
20% to 50%	13.0 to 32.5	3500	1.76
0% to 60%	0.0 to 39.0	300	2.06
50% to 80%	32.5 to 52.0	600	1.86
30% to 100%*	19.5 to 65.0	100	2.99

Negative % of Test Load	Negative Pressure Range (psf)	Number Of Cycles	Average Cycle Time (Sec)
30% to 100%*	19.5 to 65.0	50	3.00
50% to 80%	32.5 to 52.0	1050	2.49
0% to 60%	0.0 to 39.0	50	2.69
20% to 50%	13.0 to 32.5	3350	2.21

*Active Panel deflected 2.00" from original plane at 100% Positive load and 2.75" from original plane at 100% Negative load. At the completion of cycles the door panel was operable. There were no tears in the film. In our opinion, the tape and film used to seal for air leakage did not influence the results of the test.

James Hayhurst, Test Technician

IMPACT AND CYCLING TESTS

Specimen 12 ALT b – 48.00" x 120.00" – Outswing Door – X

ASTM E1886-05/1996-09 – Large Missile Impact (2 x 4 Southern Yellow Pine)

Cond. Temp Of Specimen	Missile Level	Missile Weight	Missile Length	Muzzle Distance From Specimen
75°F	D	9.0 lbs, 0 oz.	8'-0"	17'0"

Impact Location	Results	X - Measurement	Y - Measurement	Speed
1	Pass	24.25"	59.50"	50.1 fps
2	Pass	35.50"	11.25"	50.1 fps
3	Pass	24.12"	2.75 "	50.0 fps
4	Pass	44.50"	49.50"	50.0 fps

Orientation of Missile at Impact was within +/-5° of horizontal.
 None of the impacts penetrated the specimens.
 "X" measurement is from the left edge of test specimen.
 "Y" measurement is from the bottom edge of test specimen.

ASTM E1886-05/1996-09 – Fatigue Load Cycling

Design Pressure +65.0 psf / - 65.0 psf

Positive % of Test Load	Positive Pressure Range (psf)	Number Of Cycles	Average Cycle Time (Sec)
20% to 50%	13.0 to 32.5	3500	2.01
0% to 60%	0.0 to 39.0	300	2.78
50% to 80%	32.5 to 52.0	600	1.82
30% to 100%*	19.5 to 65.0	100	2.97

Negative % of Test Load	Negative Pressure Range (psf)	Number Of Cycles	Average Cycle Time (Sec)
30% to 100%*	19.5 to 65.0	50	2.92
50% to 80%	32.5 to 52.0	1050	2.35
0% to 60%	0.0 to 39.0	50	2.71
20% to 50%	13.0 to 32.5	3350	2.35

*Active Panel deflected 2.38" from original plane at 100% Positive load and 3.25" from original plane at 100% Negative load. At the completion of cycles the door panel was operable. There were no tears in the film. In our opinion, the tape and film used to seal for air leakage did not influence the results of the test.

James Hayhurst, Test Technician

IMPACT AND CYCLING TESTS

Specimen 12 ALT c – 48.00" x 120.00" – Outswing Door – X

ASTM E1886-05/1996-09 – Large Missile Impact (2 x 4 Southern Yellow Pine)

Cond. Temp Of Specimen	Missile Level	Missile Weight	Missile Length	Muzzle Distance From Specimen
75°F	D	9.0 lbs, 0 oz.	8'-0"	17'0"

Impact Location	Results	X - Measurement	Y - Measurement	Speed
1	Pass	24.12"	59.29"	50.0 fps
2	Pass	12.50"	107.50"	50.2 fps
3	Pass	24.25"	3.00 "	49.9 fps
4	Pass	44.12"	49.25"	50.1 fps

Orientation of Missile at Impact was within +/-5° of horizontal.
 None of the impacts penetrated the specimens.
 "X" measurement is from the left edge of test specimen.
 "Y" measurement is from the bottom edge of test specimen.

ASTM E1886-05/1996-09 – Fatigue Load Cycling

Design Pressure +65.0 psf / - 65.0 psf

Positive % of Test Load	Positive Pressure Range (psf)	Number Of Cycles	Average Cycle Time (Sec)
20% to 50%	13.0 to 32.5	3500	2.12
0% to 60%	0.0 to 39.0	300	2.81
50% to 80%	32.5 to 52.0	600	1.92
30% to 100%*	19.5 to 65.0	100	2.95

Negative % of Test Load	Negative Pressure Range (psf)	Number Of Cycles	Average Cycle Time (Sec)
30% to 100%*	19.5 to 65.0	50	2.69
50% to 80%	32.5 to 52.0	1050	2.41
0% to 60%	0.0 to 39.0	50	2.81
20% to 50%	13.0 to 32.5	3350	2.42

*Active Panel deflected 2.25" from original plane at 100% Positive load and 3.12" from original plane at 100% Negative load. At the completion of cycles the door panel was operable. There were no tears in the film. In our opinion, the tape and film used to seal for air leakage did not influence the results of the test.

James Hayhurst, Test Technician

IMPACT AND CYCLING TESTS

Specimen 15a – 48.00" x 120.00" – Outswing Door – X

ASTM E1886-05/1996-09 – Large Missile Impact (2 x 4 Southern Yellow Pine)

Cond. Temp Of Specimen	Missile Level	Missile Weight	Missile Length	Muzzle Distance From Specimen
75°F	D	9.0 lbs, 1 oz.	8'-1/2"	17'0"

Impact Location	Results	X - Measurement	Y - Measurement	Speed
1	Pass	24.00"	60.00"	50.0 fps
2	Pass	44.00"	48.00"	49.7 fps
3	Pass	24.00"	3.00 "	49.9 fps
4	Pass	35.00"	12.00"	50.1 fps

Orientation of Missile at Impact was within +/-5° of horizontal.
None of the impacts penetrated the specimens.
"X" measurement is from the left edge of test specimen.
"Y" measurement is from the bottom edge of test specimen.

ASTM E1886-05/1996-09 – Fatigue Load Cycling

Design Pressure +65.0 psf / - 65.0 psf

Positive % of Test Load	Positive Pressure Range (psf)	Number Of Cycles	Average Cycle Time (Sec)
20% to 50%	13.0 to 32.5	3500	1.78
0% to 60%	0.0 to 39.0	300	2.80
50% to 80%	32.5 to 52.0	600	2.09
30% to 100%*	19.5 to 65.0	100	3.00

Negative % of Test Load	Negative Pressure Range (psf)	Number Of Cycles	Average Cycle Time (Sec)
30% to 100%*	19.5 to 65.0	50	2.99
50% to 80%	32.5 to 52.0	1050	2.66
0% to 60%	0.0 to 39.0	50	3.00
20% to 50%	13.0 to 32.5	3350	2.30

*Active Panel deflected 2.25" from original plane at 100% Positive load and 3.00" from original plane at 100% Negative load. At the completion of cycles the door panel was operable. There were no tears in the film. In our opinion, the tape and film used to seal for air leakage did not influence the results of the test.

James Hayhurst, Test Technician

Conditions, Terms, and General Notes Regarding These Tests

The product tested **Has Been** compared to the detailed drawing, bill of materials and fabrication information supplied by the client so named herein. Our analysis, which includes dimensional and component description comparisons, indicate the tested product and engineering information supplied by the client **"Are Equivalent"**. The report and representative samples will be retained for four years from the date of initial test.

These test results were obtained by employing all requirements of the designated test methods with no Deviations unless explicitly noted in test report. The test results and specimen supplied for testing are in compliance with the reference.

The test results are specific to the product tested by this laboratory and of the sample supplied by the client named herein, and they relate to no other product either manufactured by the client, a fabricator of the client or of the client or of installed field performance.

This test report does not constitute certification of this product, but only that the above test results were obtained using the designated test methods and they indicate compliance with the performance requirements (paragraphs as listed) of the above referenced specifications.

Testing Evaluation Laboratories, Inc. makes no opinions or endorsements regarding this product and its performance. This report may not be reproduced or quoted in partial form without the expressed written approval of Testing Evaluation Laboratories, Inc.

Testing Evaluation Laboratories, Inc.'s letter, reports, its name or insignia or mark are for the exclusive use of the client so named herein and any other use is strictly prohibited. The report, letters and the name of Testing Evaluation Laboratories, Inc., its seal or mark shall not be used in any circumstance to the general public or in any advertising.

Limitation of liability: Due diligence was used in performing the tests and reporting the results. By acceptance of this report, this client agrees to hold harmless and indemnify Testing Evaluation Laboratories, Inc., its employees, sub-contractors, officers and owners against all claims and demands of any kind whatsoever, which arise out of or in any manner connected with the performance of work referred to herein.

Testing Evaluation Laboratories, Inc.



Vivian K. Wright,
President

Revision Log

Rev No.	Date	Page(s)	Revision(s)
0	6/26/2015	NA	Original Report Issue

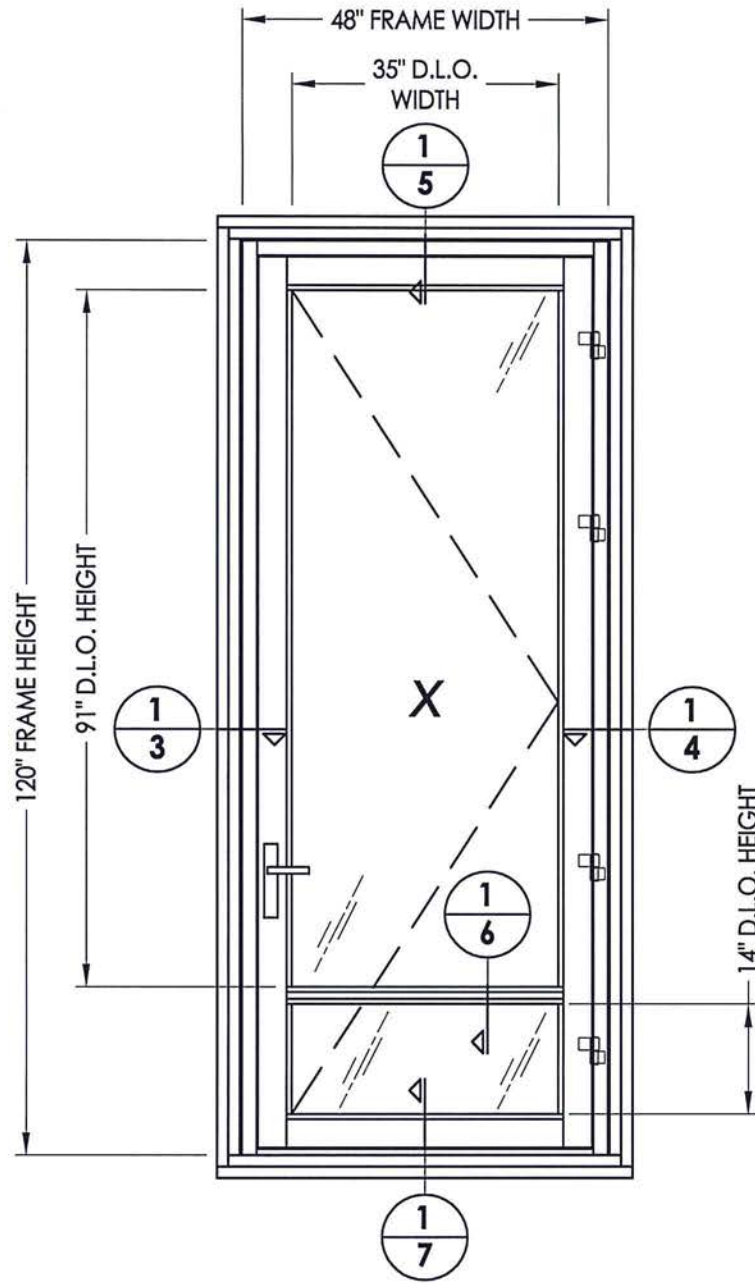

Testing Evaluation Laboratories Inc.
 Specimen Complies with Drawing
 Deviations Noted - TEL# 01991342
 Date 6/26/15 Verified by *[Signature]*

PRODUCT: FLEETWOOD SPEC. #8		PART OR ASSEMBLY: TEST ELEVATIONS	
NO.		DATE	REVISIONS
BY			
DATE: 3/17/15			
SCALE: N.T.S.			
DWG. BY: JK			
CHK. BY: LFS			
DRAWING NO.: L-7353			
SHEET 2 OF 10			

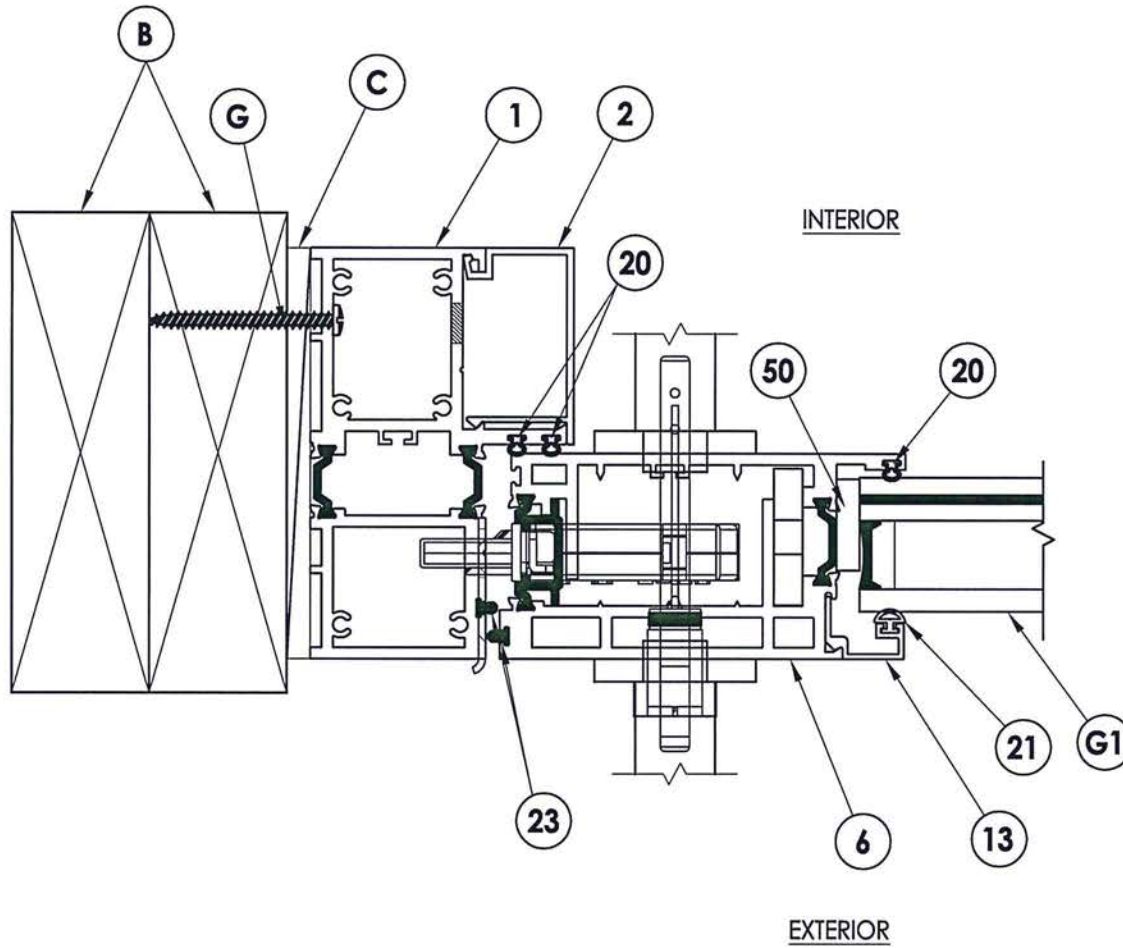

1
3 **HORIZONTAL CROSS SECTION**

Testing Evaluation Laboratories Inc.
 Specimen Complies with Drawing
 Deviations Noted - TEL# 01991342
 Date 6/26/15 Verified by EW

PRODUCT: FLEETWOOD SPEC. #8		PART OR ASSEMBLY: HORIZONTAL CROSS SECTIONS	
NO.	DATE	REVISIONS	BY
RW BUILDING CONSULTANTS, INC. 813.659.9197			
DATE: 3/17/15			
SCALE: N.T.S.			
DWG. BY: JK			
CHK. BY: LFS			
DRAWING NO.: L-7353			
SHEET 3 OF 10			

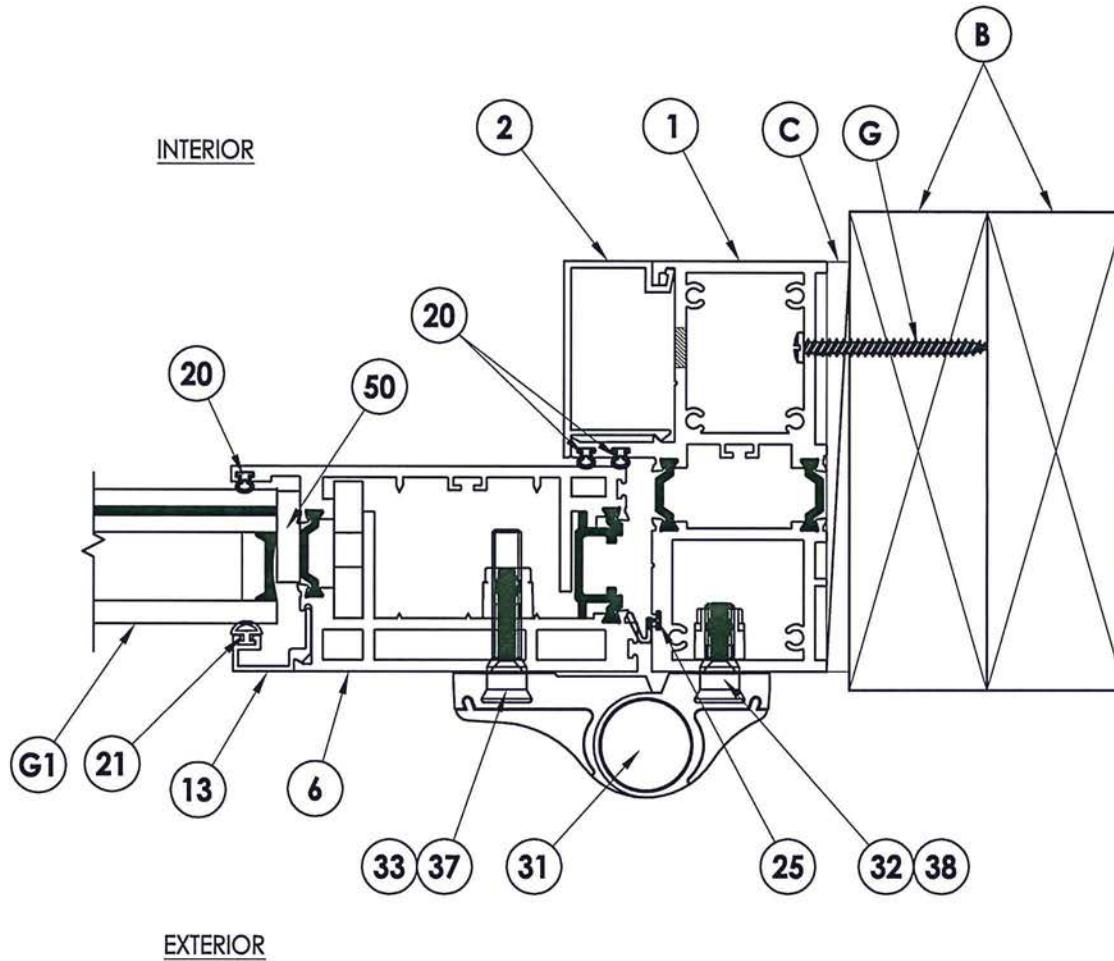

INTERIOR

EXTERIOR

1
4 HORIZONTAL CROSS SECTION

Testing Evaluation Laboratories Inc.
 Specimen Complies with Drawing
 Deviations Noted - TEL# 01991342
 Date 6/26/15 Verified by [Signature]

PRODUCT: FLEETWOOD SPEC. #8		PART OR ASSEMBLY: HORIZONTAL CROSS SECTIONS	
NO.	DATE	REVISIONS	BY
RW BUILDING CONSULTANTS, INC. 813.659.9197			
DATE: 3/17/15			
SCALE: N.T.S.			
DWG. BY: JK			
CHK. BY: LFS			
DRAWING NO.: L-7353			
SHEET 4 OF 10			

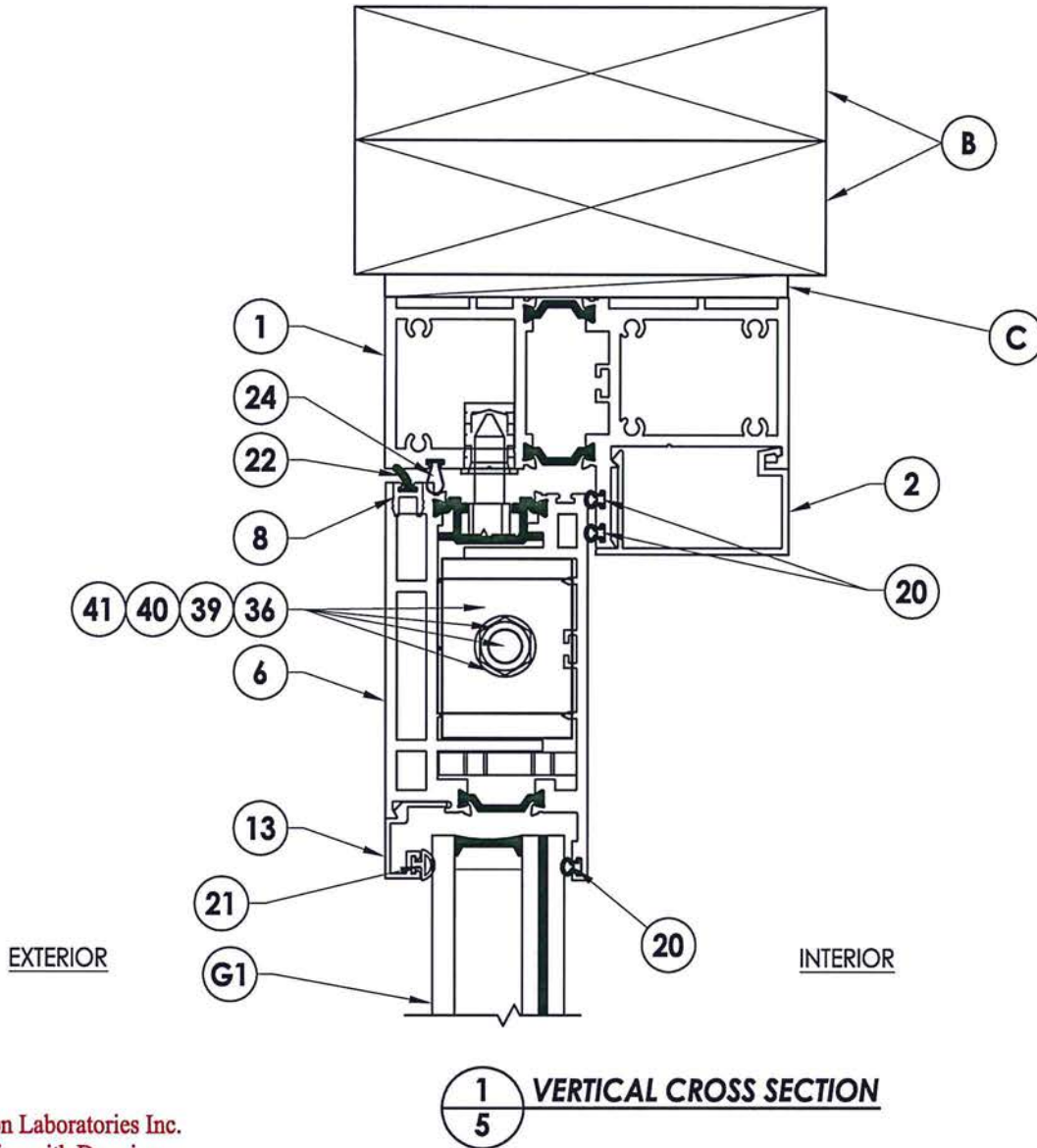

1
5 **VERTICAL CROSS SECTION**

Testing Evaluation Laboratories Inc.
 Specimen Complies with Drawing
 Deviations Noted - TEL# 01991342
 Date 6/26/15 Verified by [Signature]

PRODUCT: FLEETWOOD SPEC. #8		PART OR ASSEMBLY: VERTICAL CROSS SECTIONS	
NO.	DATE	REVISIONS	BY
DATE: 3/17/15			
SCALE: N.T.S.			
DWG. BY: JK			
CHK. BY: LFS			
DRAWING NO.: L-7353			
SHEET 5 OF 10			

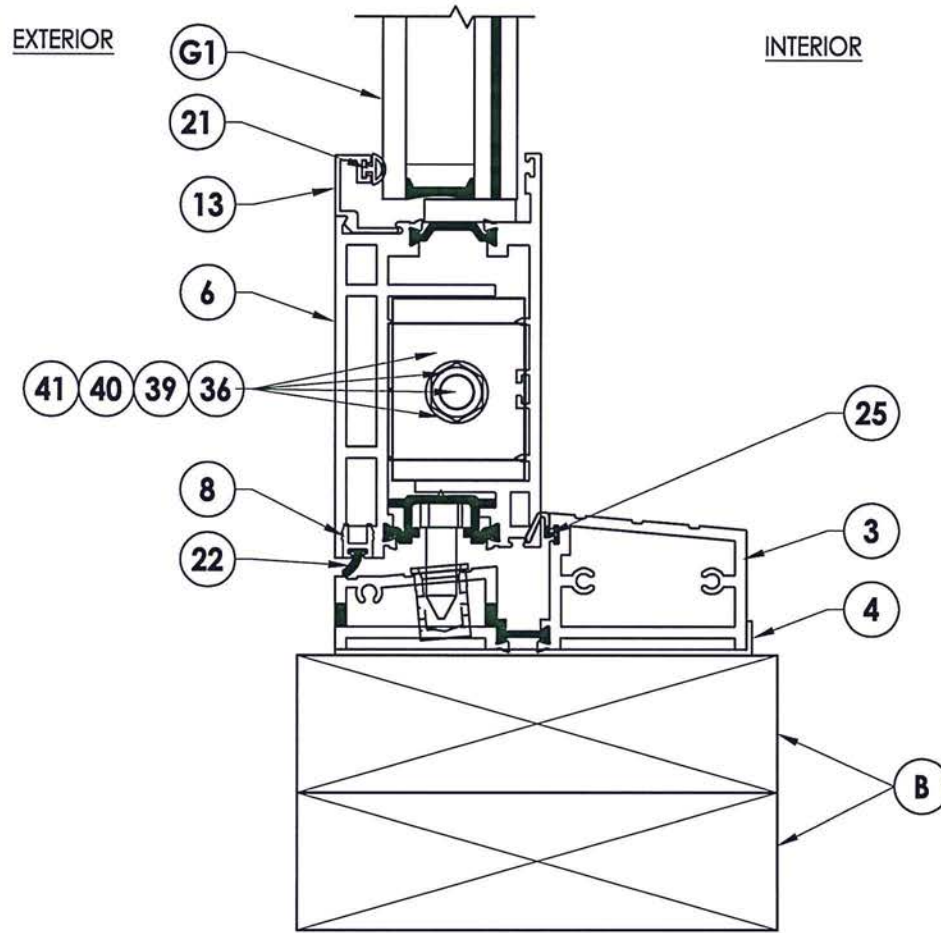

1
7 **VERTICAL CROSS SECTION**

Testing Evaluation Laboratories Inc.
 Specimen Complies with Drawing
 Deviations Noted - TEL# 01991342
 Date 6/26/15 Verified by [Signature]

PRODUCT: FLEETWOOD SPEC. #8		PART OR ASSEMBLY: VERTICAL CROSS SECTIONS	
NO.	DATE	REVISIONS	BY
DATE: 3/17/15			
SCALE: N.T.S.			
DWG. BY: JK			
CHK. BY: LFS			
DRAWING NO.: L-7353			
SHEET 7 OF 10			

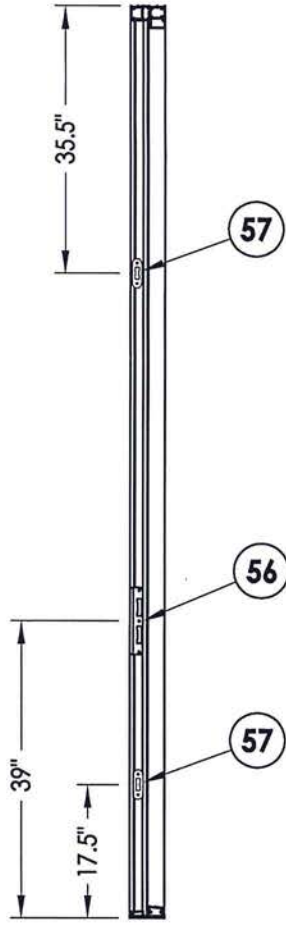

STRIKE PLATE DETAIL

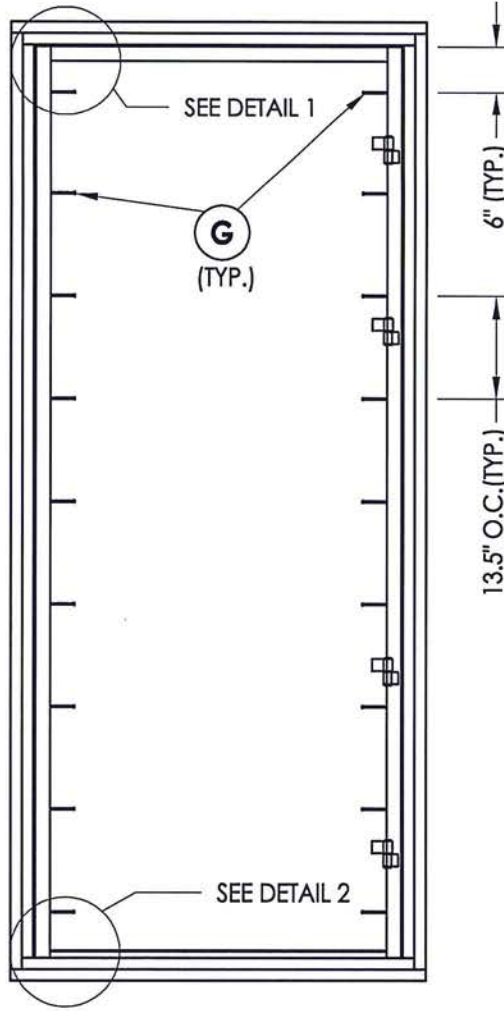

**FRAME ANCHORING
(2X buck installation)**

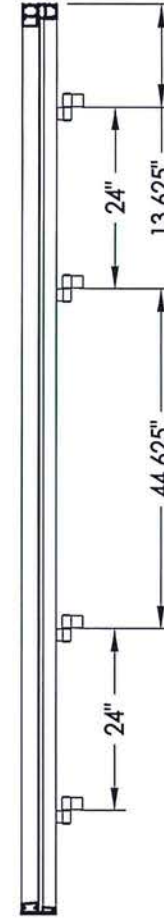

HINGE DETAIL

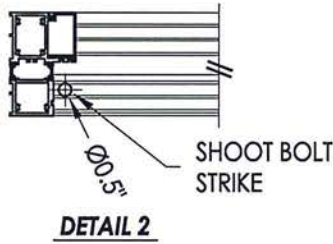

DETAIL 2

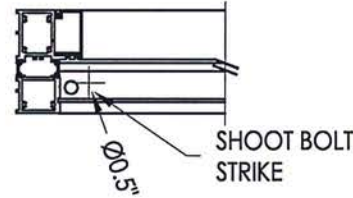

DETAIL 1

Testing Evaluation Laboratories Inc.
 Specimen Complies with Drawing
 Deviations Noted - TEL# 01991342
 Date 6/26/15 Verified by *[Signature]*

PRODUCT: FLEETWOOD SPEC. #8		PART OR ASSEMBLY: TEST ELEVATIONS	
NO.	DATE	REVISIONS	BY
			
DATE: 3/17/15			
SCALE: N.T.S.			
DWG. BY: JK			
CHK. BY: LFS			
DRAWING NO.: L-7353			
SHEET 8 OF 10			

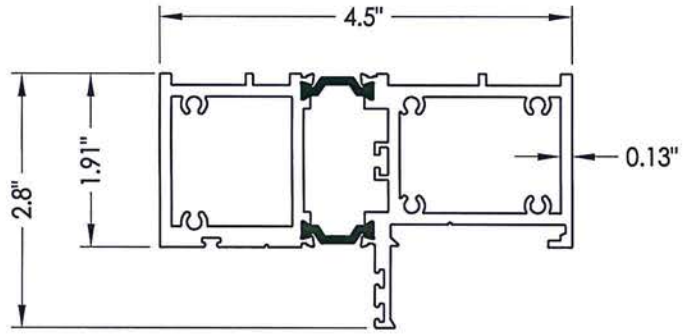

1 BLOCK HEAD & JAMBS

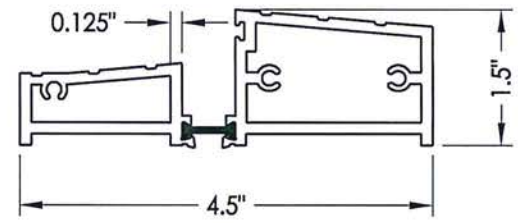

3 OUT-SWING SILL

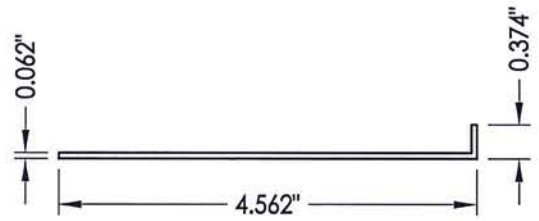

4 SILL PAN

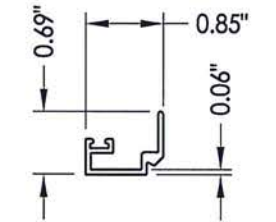

13 1-1/2" GLASS STOP

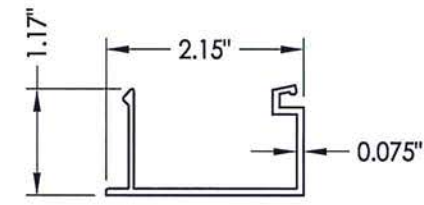

2 FRAME SNAP-IN

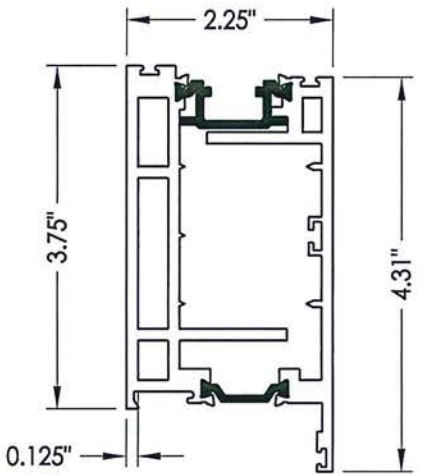

6 SASH

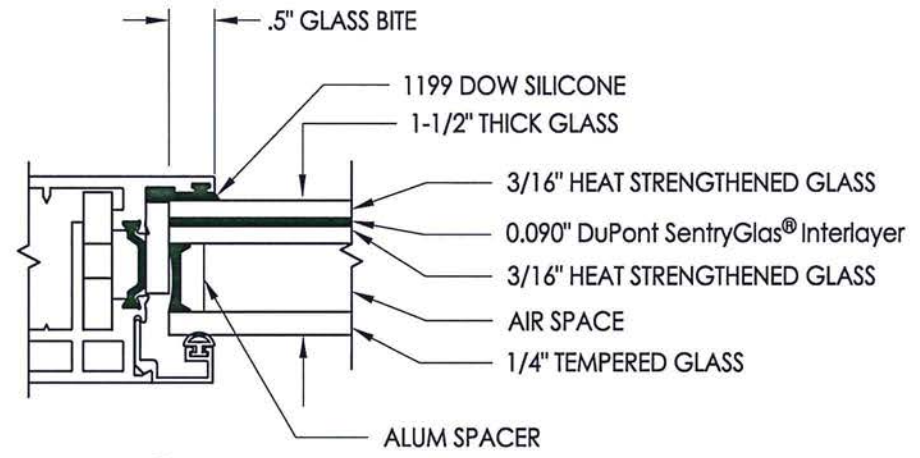

G1 GLAZING DETAIL

Testing Evaluation Laboratories Inc.
 Specimen Complies with Drawing
 Deviations Noted - TEL# 01991342
 Date 6/26/15 Verified by *[Signature]*

PRODUCT:		FLEETWOOD SPEC. #8	
PART OR ASSEMBLY:		COMPONENTS AND GLAZING DETAIL	
NO.	DATE	BY	REVISIONS
 BUILDING CONSULTANTS, INC. 813.659.9197			
DATE: 3/17/15			
SCALE: N.T.S.			
DWG. BY: JK			
CHK. BY: LFS			
DRAWING NO.: L-7353			
SHEET 9 OF 10			

BILL OF MATERIALS			
ITEM #	DESCRIPTION	PART#	MATERIAL
B	2X BUCK SG >= 0.55	-	WOOD
C	1/4" MAX. SHIM SPACE	-	-
G	#10 x 2" PPH WOOD SCREW	-	STEEL
1	FRAME	3911	6063-T6 ALUM
2	FRAME SNAP-IN	3912	6063-T6 ALUM
3	OUT-SWING SILL	3202	6063-T6 ALUM
4	SILL PAN	-	-
6	SASH	3902	6063-T6 ALUM
8	ATLANTIC SEAL CLIP	3916	6063-T6 ALUM
13	1-1/2" GLASS STOP	3908	6063-T6 ALUM
21	BULB VINYL - LARGE (EPDM 70 Durometer)	25031	TREMCO, # TX19638E
22	FOAM SEAL	25196	EMESBURY, # 32390
23	Q-LON FOAM SEAL	25189	SCHLEGEL CORP., # Q225T190
24	Q-LON FOAM SEAL	25058	SCHLEGEL CORP., # Q375T190
25	Q-LON FOAM SEAL	25059	SCHLEGEL CORP., # QEZ 376
31	BUTT HINGE	-	SAVIO
32	BACK UP KIT	20535	SAVIO
33	HINGE BOLT, 8M X 48MM (FOR PANEL)	25026	SAVIO
36	BACK UP PLATE FOR CORNER BLOCK	25025	-
37	MACHINE SCREW NO 10-32, FHP 1.125"	25074	STAINLESS STEEL
38	MACHINE SCREW NO 10-32, FHP .75"	25073	STAINLESS STEEL
39	HEX HEAD CAP SCREW .375-16, 2.250"	25175	STAINLESS STEEL
40	.375-16 SS. HEX NUT	25023	STAINLESS STEEL
41	.375 SPLIT LOCK WASHER	25024	STAINLESS STEEL
50	4" LONG SETTING BLOCK	18620	-
56	LATCH AND DEADBOLT STRIKE PLATE	-	-
57	STRIKE PLATE	-	-
60	TDL BAR	3914	6063-T6 ALUM

PRODUCT:		FLEETWOOD SPEC. #8	
PART OR ASSEMBLY:		BILL OF MATERIALS	
NO.	DATE	BY	REVISIONS
			
DATE: 3/17/15			
SCALE: N.T.S.			
DWG. BY: JK			
CHK. BY: LFS			
DRAWING NO.: L-7353			
SHEET 10 OF 10			

Testing Evaluation Laboratories Inc.
 Specimen Complies with Drawing
 Deviations Noted - TEL# 01991342
 Date 6/26/15 Verified by *[Signature]*

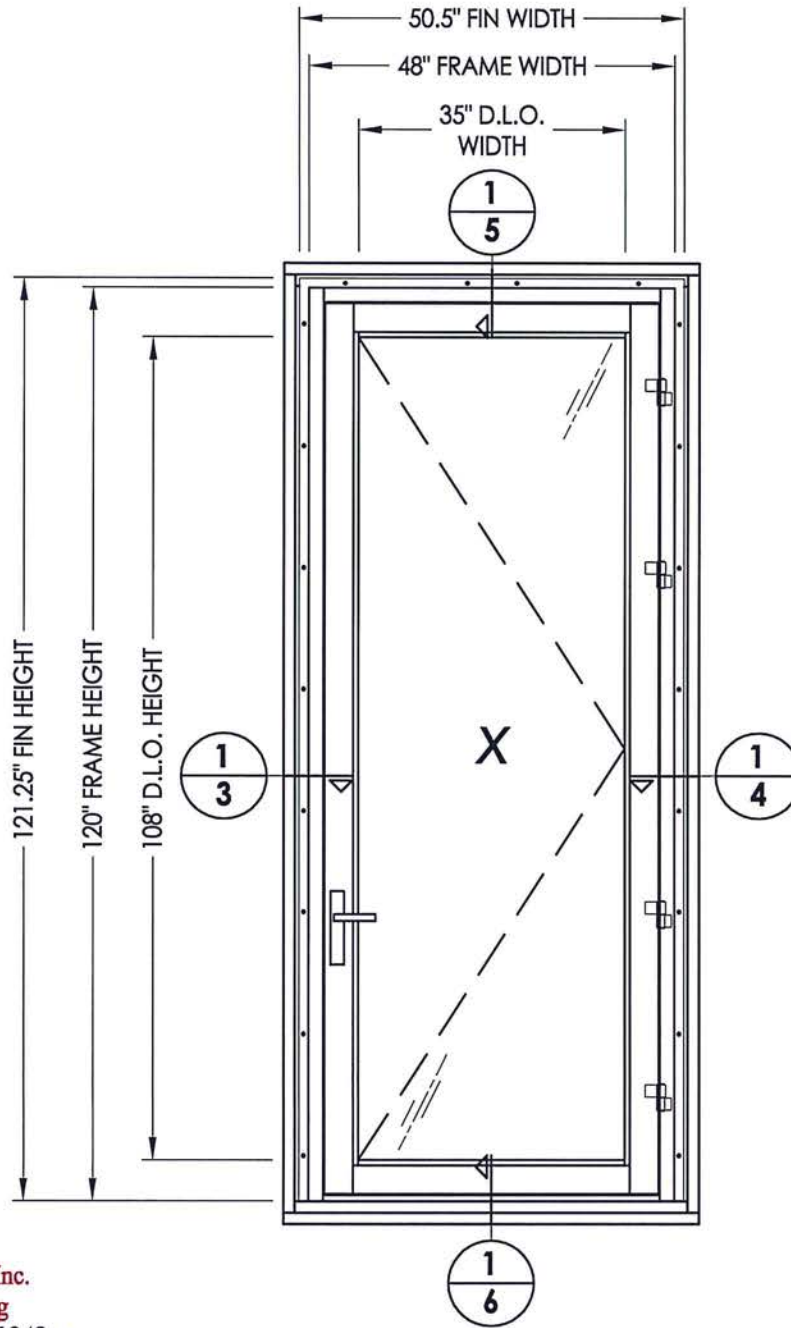

Testing Evaluation Laboratories Inc.
 Specimen Complies with Drawing
 Deviations Noted - TEL# 01991342
 Date 6/26/15 Verified by [Signature]

Note: Factory Crimped Stile

PRODUCT: FLEETWOOD SPEC. #12, 12A		PART OR ASSEMBLY: TEST ELEVATIONS	
NO.	DATE	REVISIONS	BY
		DATE: 3/17/15 SCALE: N.T.S. DWG. BY: JK CHK. BY: LFS DRAWING NO.: L-7343 SHEET <u>2</u> OF <u>9</u>	

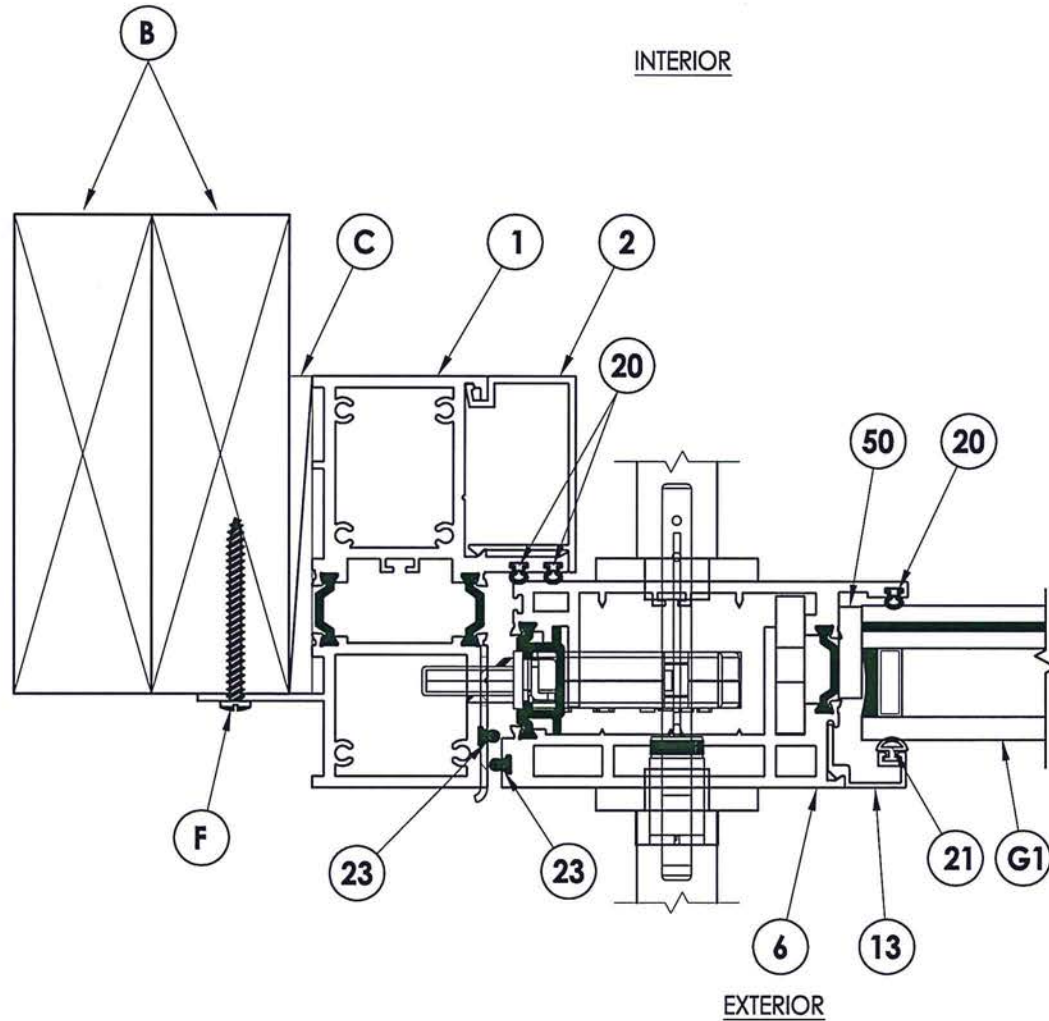

1
3 HORIZONTAL CROSS SECTION

Testing Evaluation Laboratories Inc.
 Specimen Complies with Drawing
 Deviations Noted - TEL# 01991342
 Date 6/26/15 Verified by *[Signature]*

PRODUCT: FLEETWOOD SPEC. #12, 12A		PART OR ASSEMBLY: HORIZONTAL CROSS SECTIONS	
NO.	DATE	REVISIONS	BY
DATE: 3/17/15			
SCALE: N.T.S.			
DWG. BY: JK			
CHK. BY: LFS			
DRAWING NO.: L-7343			
SHEET 3 OF 9			

INTERIOR

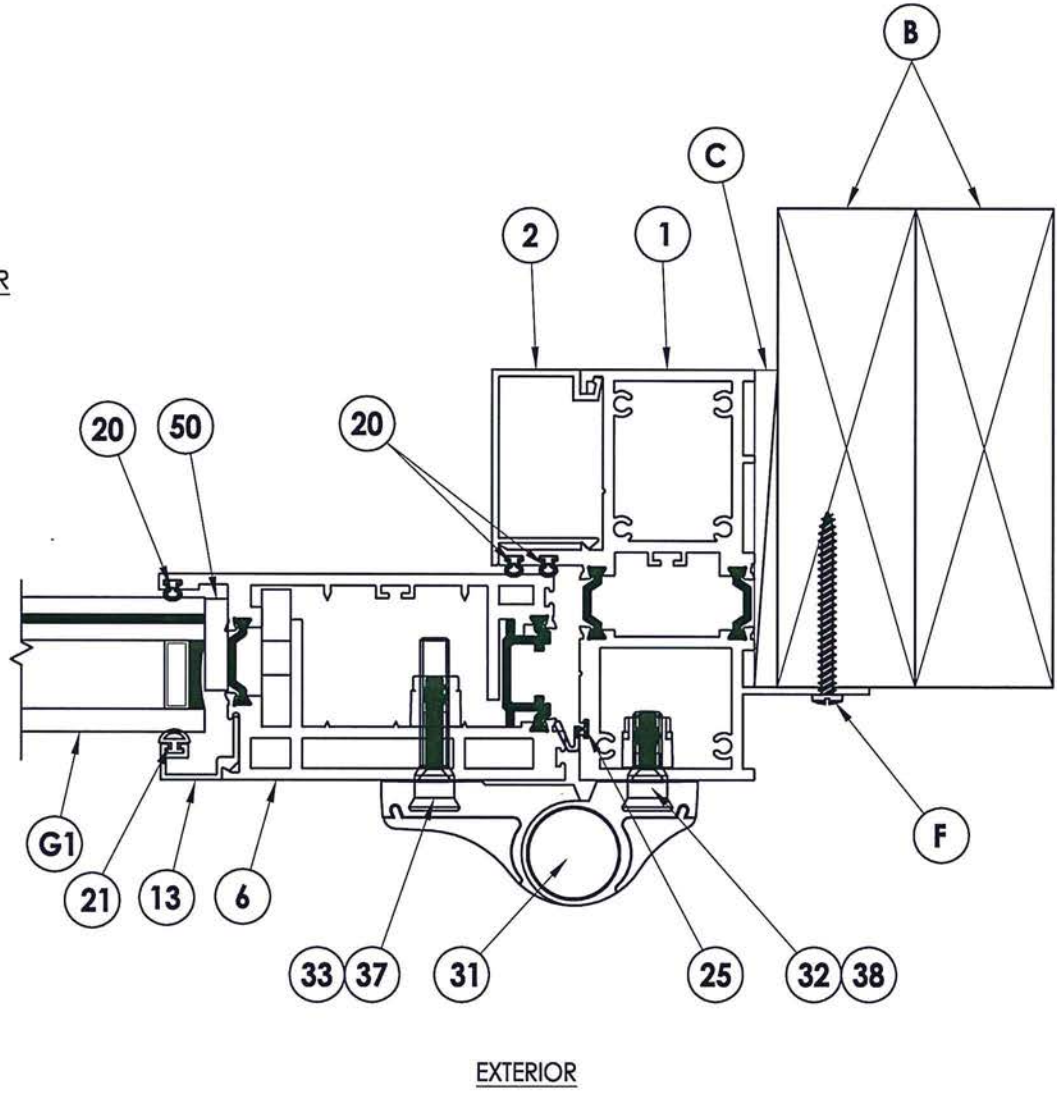

EXTERIOR

1
4 HORIZONTAL CROSS SECTION

Testing Evaluation Laboratories Inc.
 Specimen Complies with Drawing
 Deviations Noted - TEL# 01991342
 Date 6/26/15 Verified by *[Signature]*

PRODUCT: FLEETWOOD SPEC. #12, 12A		PART OR ASSEMBLY: HORIZONTAL CROSS SECTIONS	
NO.	DATE	REVISIONS	BY
 RW BUILDING CONSULTANTS, INC. 813.659.9197			
DATE: 3/17/15			
SCALE: N.T.S.			
DWG. BY: JK			
CHK. BY: LFS			
DRAWING NO.:			
L-7343			
SHEET 4 OF 9			

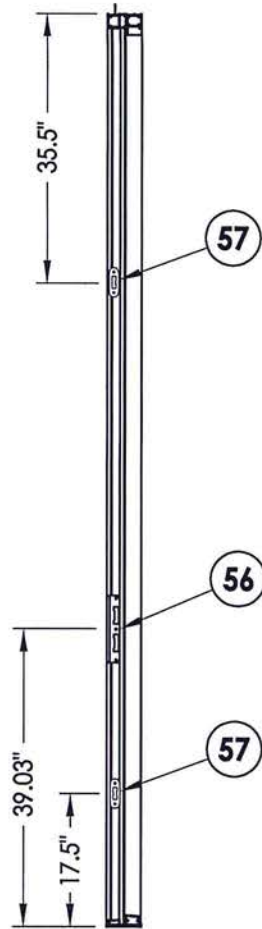

STRIKE PLATE DETAIL

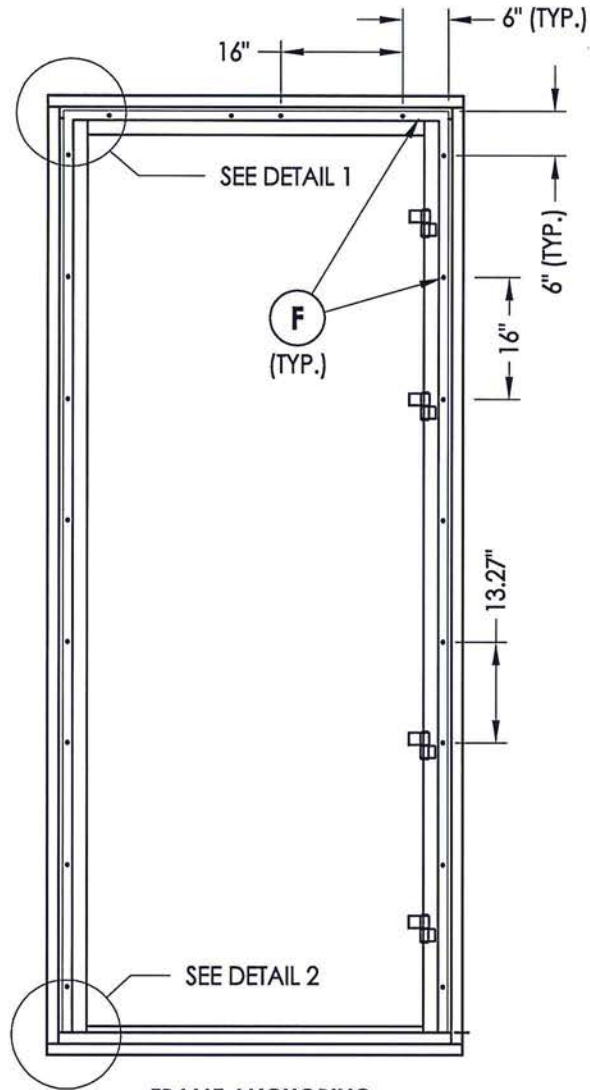

FRAME ANCHORING
(2X buck installation)

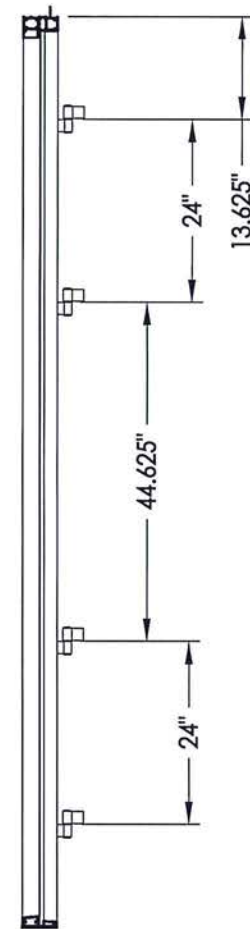

HINGE DETAIL

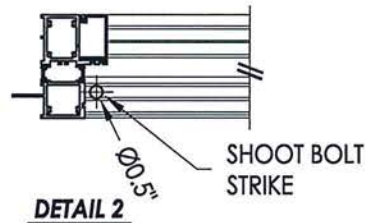

DETAIL 2

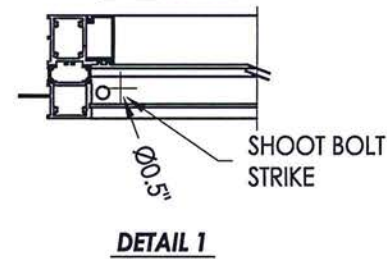

DETAIL 1

Testing Evaluation Laboratories Inc.
 Specimen Complies with Drawing
 Deviations Noted - TEL# 01991342
 Date 6/26/15 Verified by [Signature]

PRODUCT: FLEETWOOD SPEC. #12, 12A		PART OR ASSEMBLY: TEST ELEVATIONS	
NO.	DATE	REVISIONS	BY
 RW BUILDING CONSULTANTS, INC. 813.659.9197			
DATE: 3/17/15			
SCALE: N.T.S.			
DWG. BY: JK			
CHK. BY: LFS			
DRAWING NO.: L-7343			
SHEET 7 OF 9			

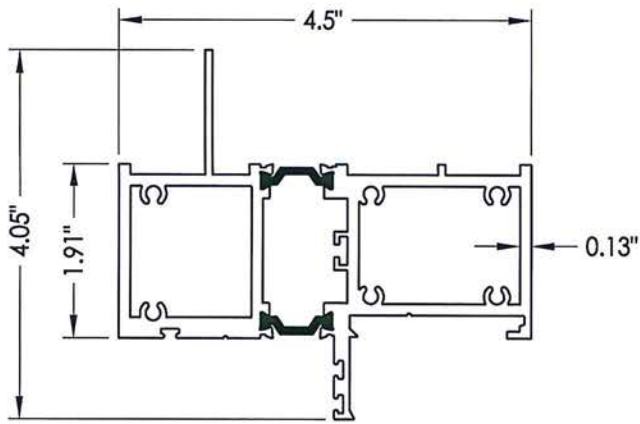

1 BLOCK HEAD & JAMBS

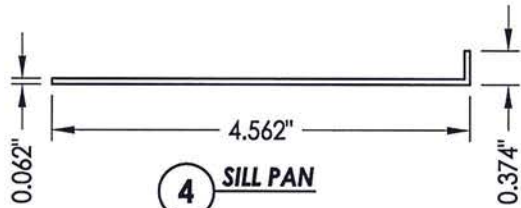

4 SILL PAN

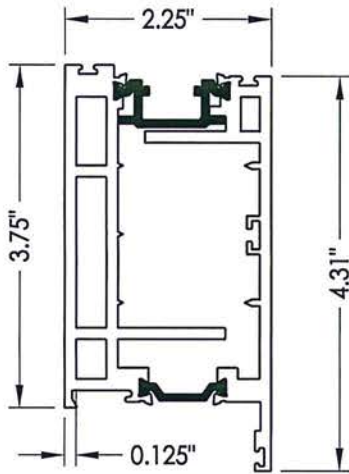

6 SASH

Testing Evaluation Laboratories Inc.
 Specimen Complies with Drawing
 Deviations Noted - TEL# 01991342
 Date 6/26/15 Verified by *[Signature]*

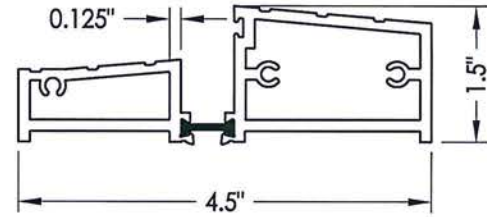

3 OUT-SWING SILL

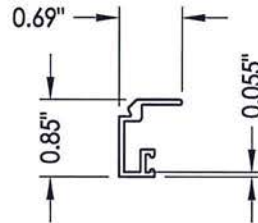

13 1.5" GLASS STOP

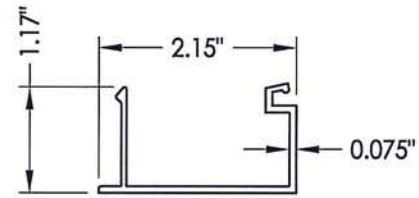

2 FRAME SNAP-IN

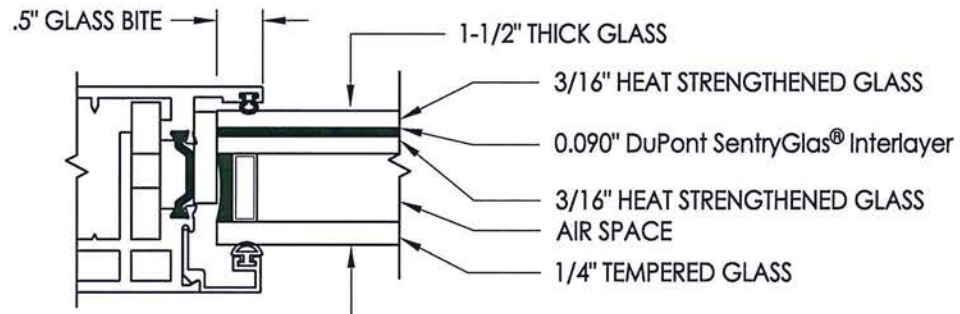

G1 GLAZING DETAIL

PRODUCT:		FLEETWOOD SPEC. #12, 12A	
PART OR ASSEMBLY:		COMPONENTS AND GLAZING DETAIL	
NO.	DATE	BY	REVISIONS
DATE: 3/17/15			
SCALE: N.T.S.			
DWG. BY: JK			
CHK. BY: LFS			
DRAWING NO.: L-7343			
SHEET 8 OF 9			

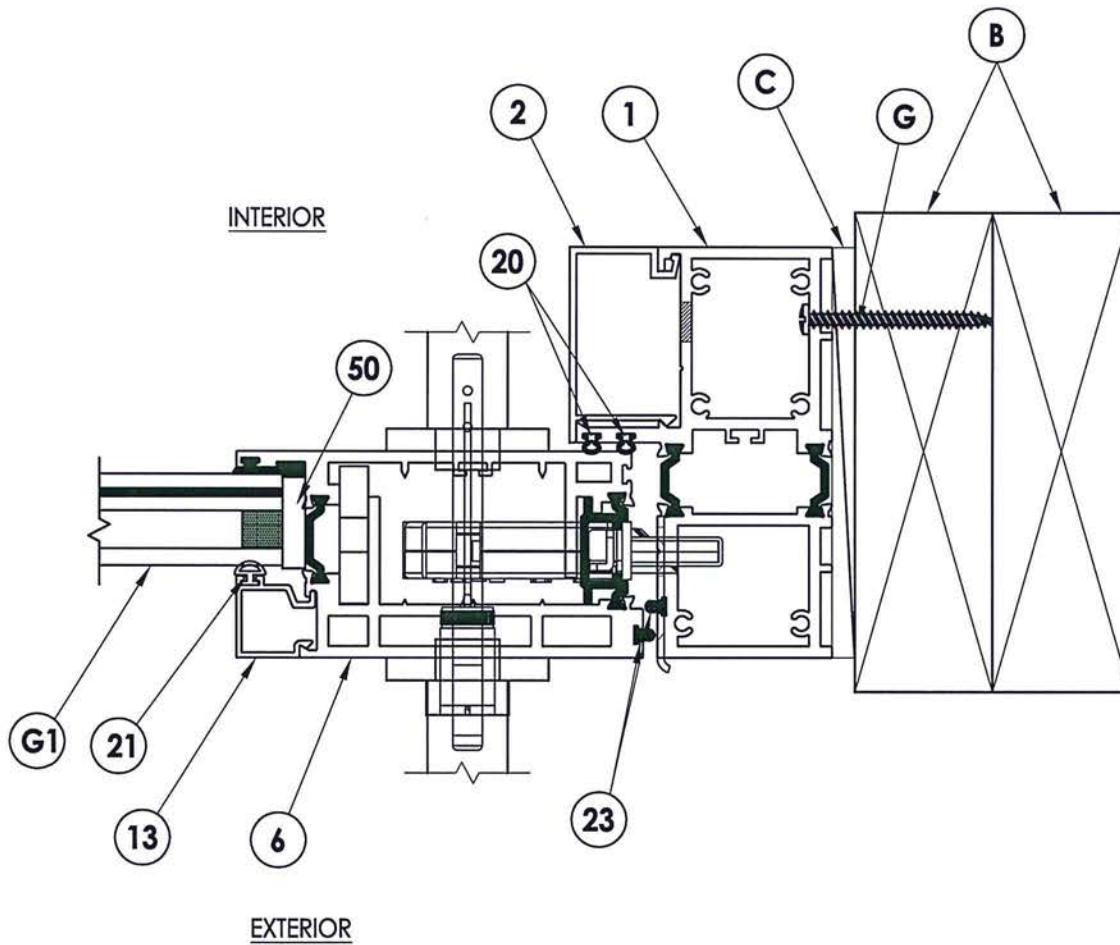

1
3 **HORIZONTAL CROSS SECTION**

Testing Evaluation Laboratories Inc.
 Specimen Complies with Drawing
 Deviations Noted - TEL# 01991342
 Date 6/26/15 Verified by [Signature]

PRODUCT:		FLEETWOOD SPEC. #12B, 12C, 12D	
PART OR ASSEMBLY:		HORIZONTAL CROSS SECTIONS	
NO.	DATE	REVISIONS	BY
DATE: 3/17/15			
SCALE: N.T.S.			
DWG. BY: JK			
CHK. BY: LFS			
DRAWING NO.:			
L-7344			
SHEET <u>3</u> OF <u>9</u>			

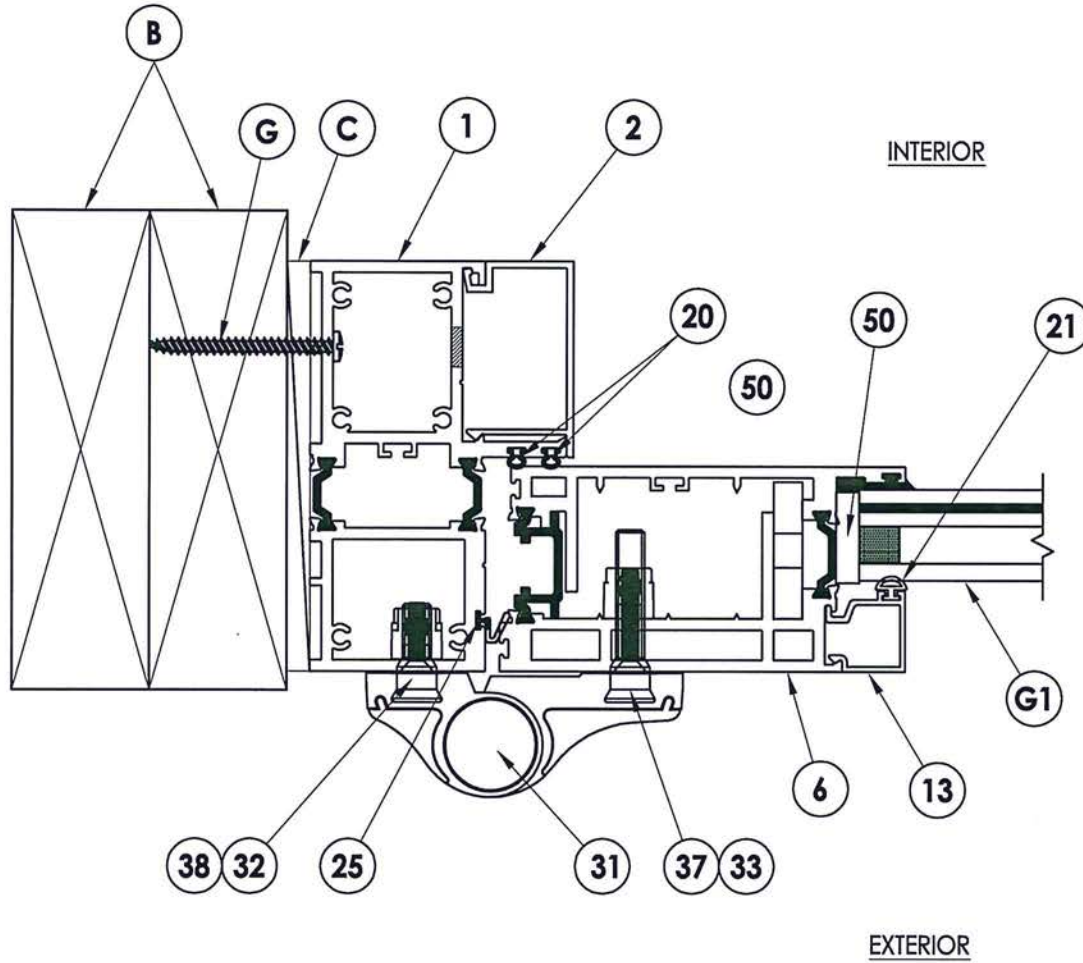

1
4 HORIZONTAL CROSS SECTION

Testing Evaluation Laboratories Inc.
 Specimen Complies with Drawing
 Deviations Noted - TEL# 01991342
 Date 6/26/15 Verified by [Signature]

PRODUCT: FLEETWOOD SPEC. #12B, 12C, 12D		PART OR ASSEMBLY: HORIZONTAL CROSS SECTIONS	
NO.	DATE	REVISIONS	BY
RW BUILDING CONSULTANTS, INC. 813.659.9197			
DATE: 3/17/15			
SCALE: N.T.S.			
DWG. BY: JK			
CHK. BY: LFS			
DRAWING NO.: L-7344			
SHEET 4 OF 9			

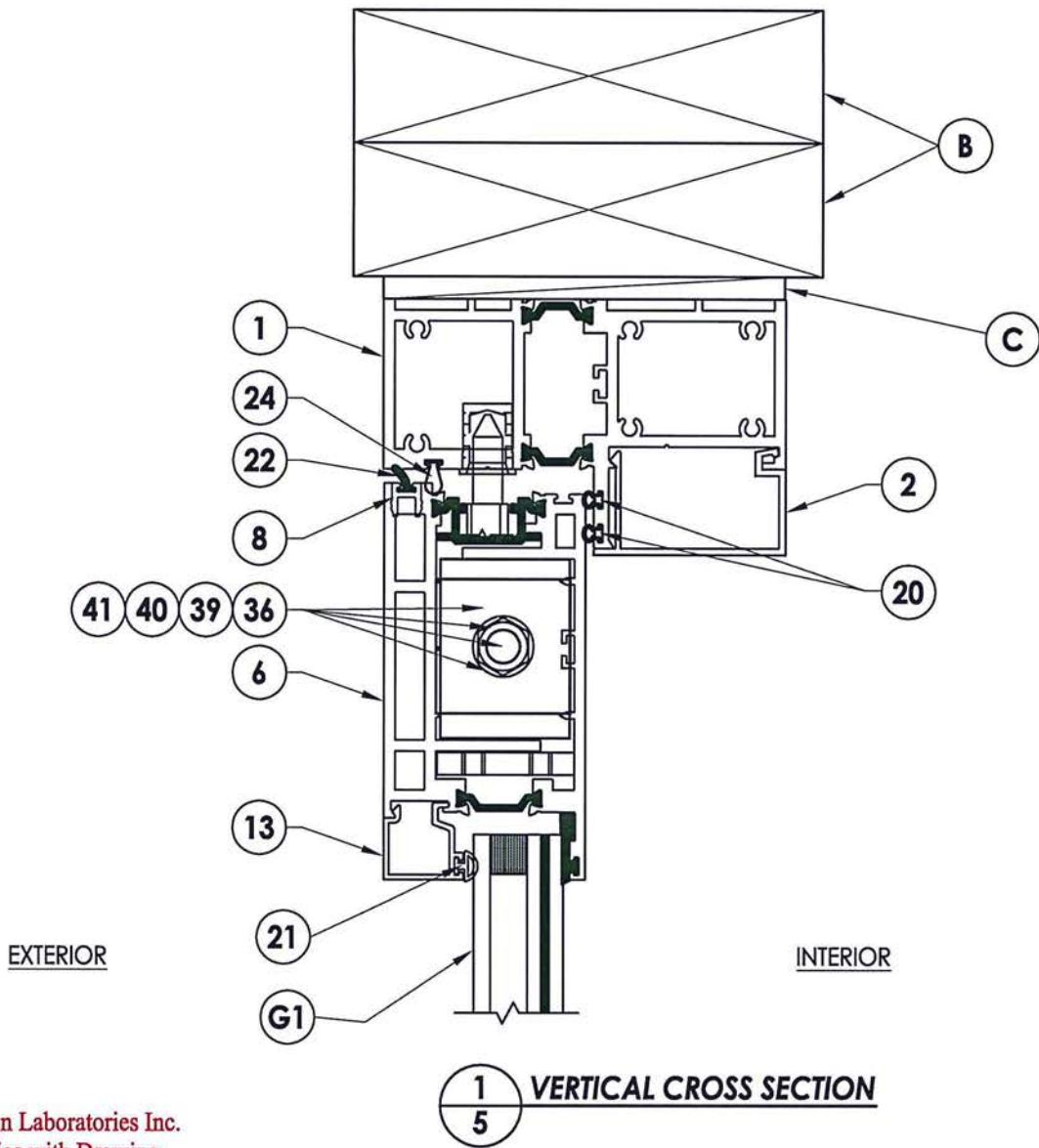

1
5 **VERTICAL CROSS SECTION**

Testing Evaluation Laboratories Inc.
 Specimen Complies with Drawing
 Deviations Noted - TEL# 0199.1342
 Date 6/26/15 Verified by [Signature]

PRODUCT: FLEETWOOD SPEC. #12B, 12C, 12D		PART OR ASSEMBLY: VERTICAL CROSS SECTIONS	
NO.	DATE	REVISIONS	BY
DATE: 3/17/15			
SCALE: N.T.S.			
DWG. BY: JK			
CHK. BY: LFS			
DRAWING NO.: L-7344			
SHEET <u>5</u> OF <u>9</u>			

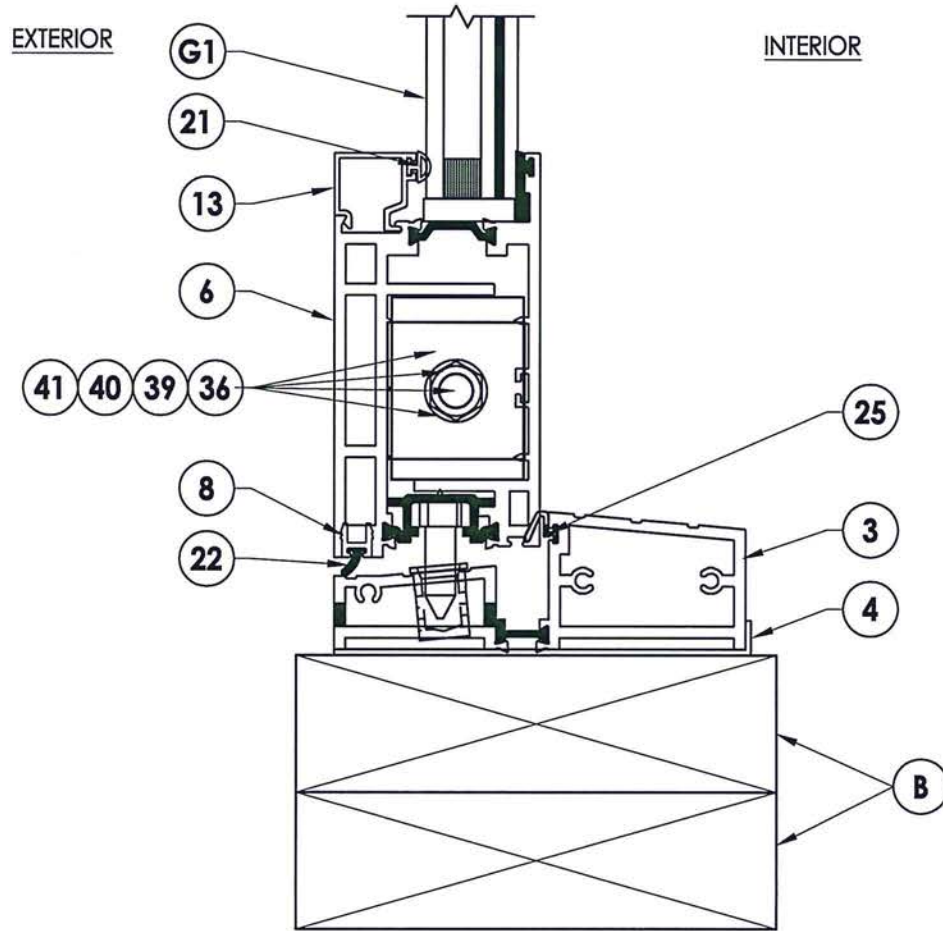

1
6 **VERTICAL CROSS SECTION**

Testing Evaluation Laboratories Inc.
 Specimen Complies with Drawing
 Deviations Noted - TEL# 01991342
 Date 6/26/15 Verified by [Signature]

PRODUCT: FLEETWOOD SPEC. #12B, 12C, 12D		PART OR ASSEMBLY: VERTICAL CROSS SECTIONS	
NO.	DATE	REVISIONS	BY
 RW BUILDING CONSULTANTS, INC. 813.659.9197			
DATE: 3/17/15			
SCALE: N.T.S.			
DWG. BY: JK			
CHK. BY: LFS			
DRAWING NO.: L-7344			
SHEET 6 OF 9			

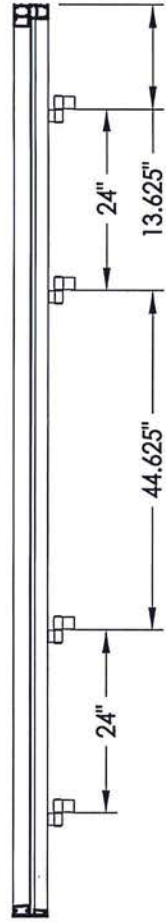

HINGE DETAIL

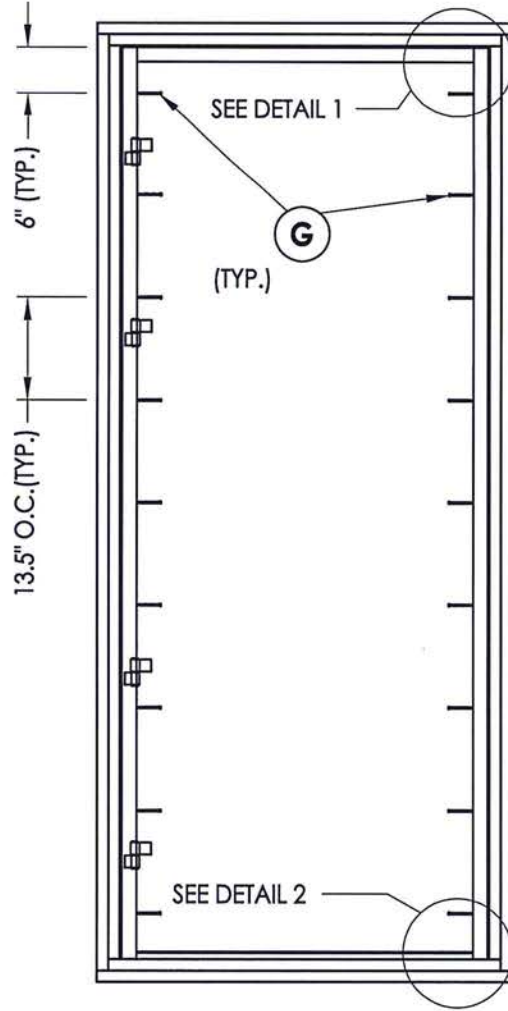

FRAME ANCHORING
(2X buck installation)

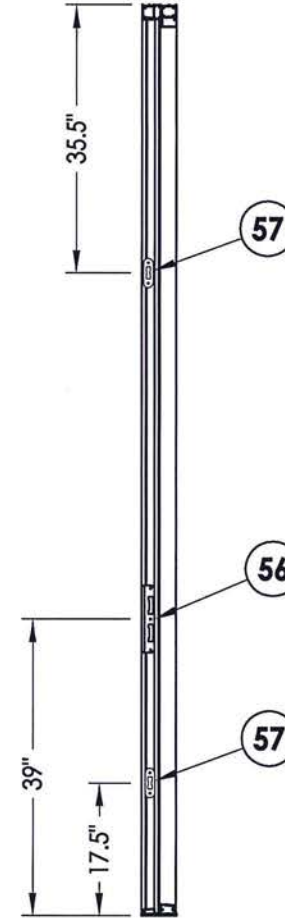

STRIKE PLATE DETAIL

Testing Evaluation Laboratories Inc.
Specimen Complies with Drawing
Deviations Noted - TEL# 01991342
Date 6/26/15 Verified by *[Signature]*

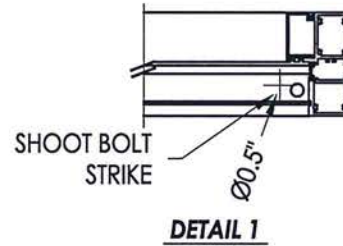
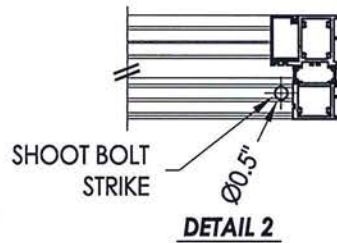

PRODUCT:		FLEETWOOD SPEC. #12B, 12C, 12D	
PART OR ASSEMBLY:		TEST ELEVATIONS	
NO.	DATE	REVISIONS	BY
DATE: 3/17/15			
SCALE: N.T.S.			
DWG. BY: JK			
CHK. BY: LFS			
DRAWING NO.: L-7344			
SHEET 7 OF 9			

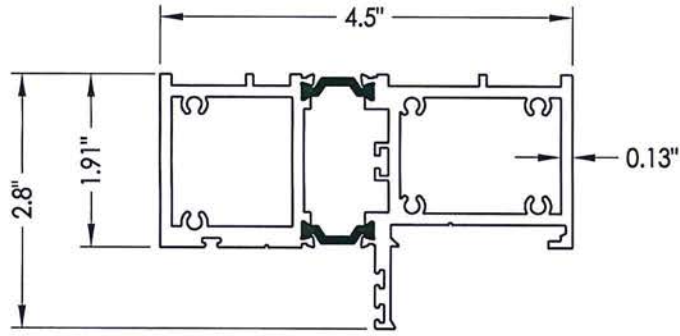

1 BLOCK HEAD & JAMBS

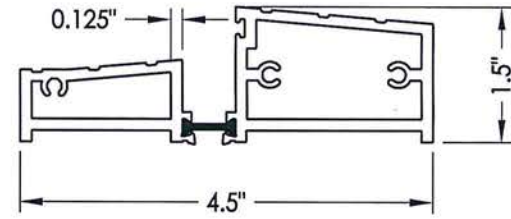

3 OUT-SWING SILL

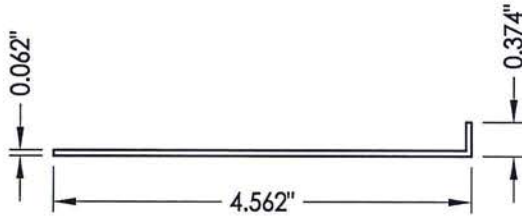

4 SILL PAN

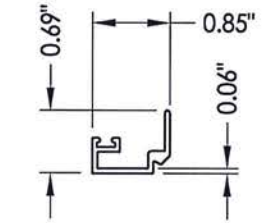

13 1-1/2" GLASS STOP

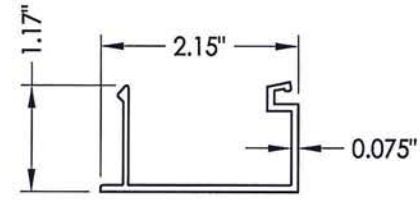

2 FRAME SNAP-IN

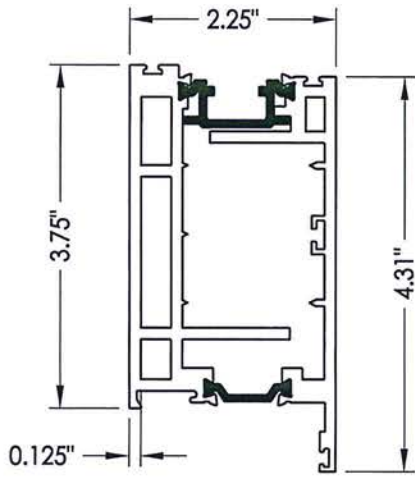

6 SASH

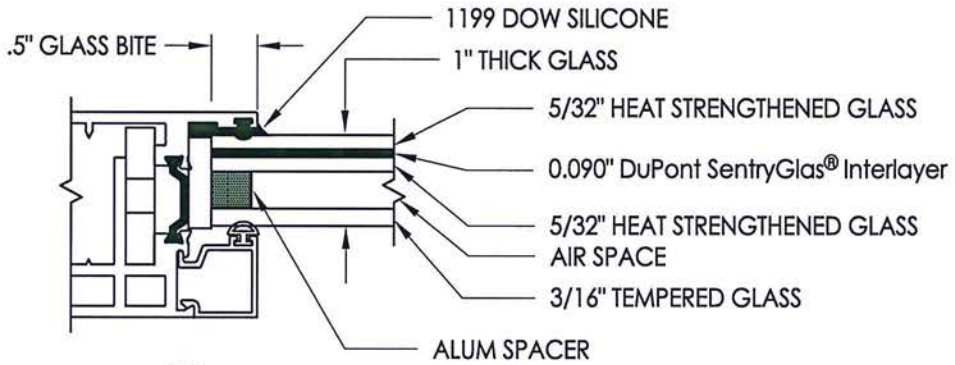

G1 GLAZING DETAIL

Testing Evaluation Laboratories Inc.
 Specimen Complies with Drawing
 Deviations Noted - TEL# 01991342
 Date 6/26/15 Verified by *[Signature]*

PRODUCT: FLEETWOOD SPEC. #12B, 12C, 12D		PART OR ASSEMBLY: COMPONENTS AND GLAZING DETAIL	
NO.	DATE	BY	REVISIONS
RW BUILDING CONSULTANTS, INC. 813.659.9197			
DATE: 3/17/15			
SCALE: N.T.S.			
DWG. BY: JK			
CHK. BY: LFS			
DRAWING NO.: L-7344			
SHEET 8 OF 9			

BILL OF MATERIALS			
ITEM #	DESCRIPTION	PART#	MATERIAL
B	2X BUCK SG >= 0.55	-	WOOD
C	1/4" MAX. SHIM SPACE	-	-
G	#10 x 2" PPH WOOD SCREW	-	STEEL
1	FRAME	3911	6063-T6 ALUM
2	FRAME SNAP-IN	3912	6063-T6 ALUM
3	OUT-SWING SILL	3202	6063-T6 ALUM
4	SILL PAN	-	-
6	SASH	3902	6063-T6 ALUM
8	ATLANTIC SEAL CLIP	3916	6063-T6 ALUM
13	1" GLASS STOP	3908	6063-T6 ALUM
21	BULB VINYL - LARGE (EPDM 70 Durometer)	25031	TREMCO, # TX19638E
22	FOAM SEAL	25196	EMESBURY, # 32390
23	Q-LON FOAM SEAL	25189	SCHLEGEL CORP., # Q225T190
24	Q-LON FOAM SEAL	25058	SCHLEGEL CORP., # Q375T190
25	Q-LON FOAM SEAL	25059	SCHLEGEL CORP., # QEZ 376
31	BUTT HINGE	-	SAVIO
32	BACK UP KIT	20535	SAVIO
33	HINGE BOLT, 8M X 48MM (FOR PANEL)	25026	SAVIO
36	BACK UP PLATE FOR CORNER BLOCK	25025	-
37	MACHINE SCREW NO 10-32, FHP 1.125"	25074	STAINLESS STEEL
38	MACHINE SCREW NO 10-32, FHP .75"	25073	STAINLESS STEEL
39	HEX HEAD CAP SCREW .375-16, 2.250"	25175	STAINLESS STEEL
40	.375-16 SS. HEX NUT	25023	STAINLESS STEEL
41	.375 SPLIT LOCK WASHER	25024	STAINLESS STEEL
50	4" LONG SETTING BLOCK	18620	-
56	LATCH AND DEADBOLT STRIKE PLATE	-	-
57	STRIKE PLATE	-	-

PRODUCT:		FLEETWOOD SPEC. #12B, 12C, 12D	
PART OR ASSEMBLY:		BILL OF MATERIALS	
NO.	DATE	BY	REVISIONS
			
DATE: 3/17/15			
SCALE: N.T.S.			
DWG. BY: JK			
CHK. BY: LFS			
DRAWING NO.: L-7344			
SHEET 9 OF 9			

Testing Evaluation Laboratories Inc.
 Specimen Complies with Drawing
 Deviations Noted - TEL# 01991342
 Date 6/26/15 Verified by: *[Signature]*

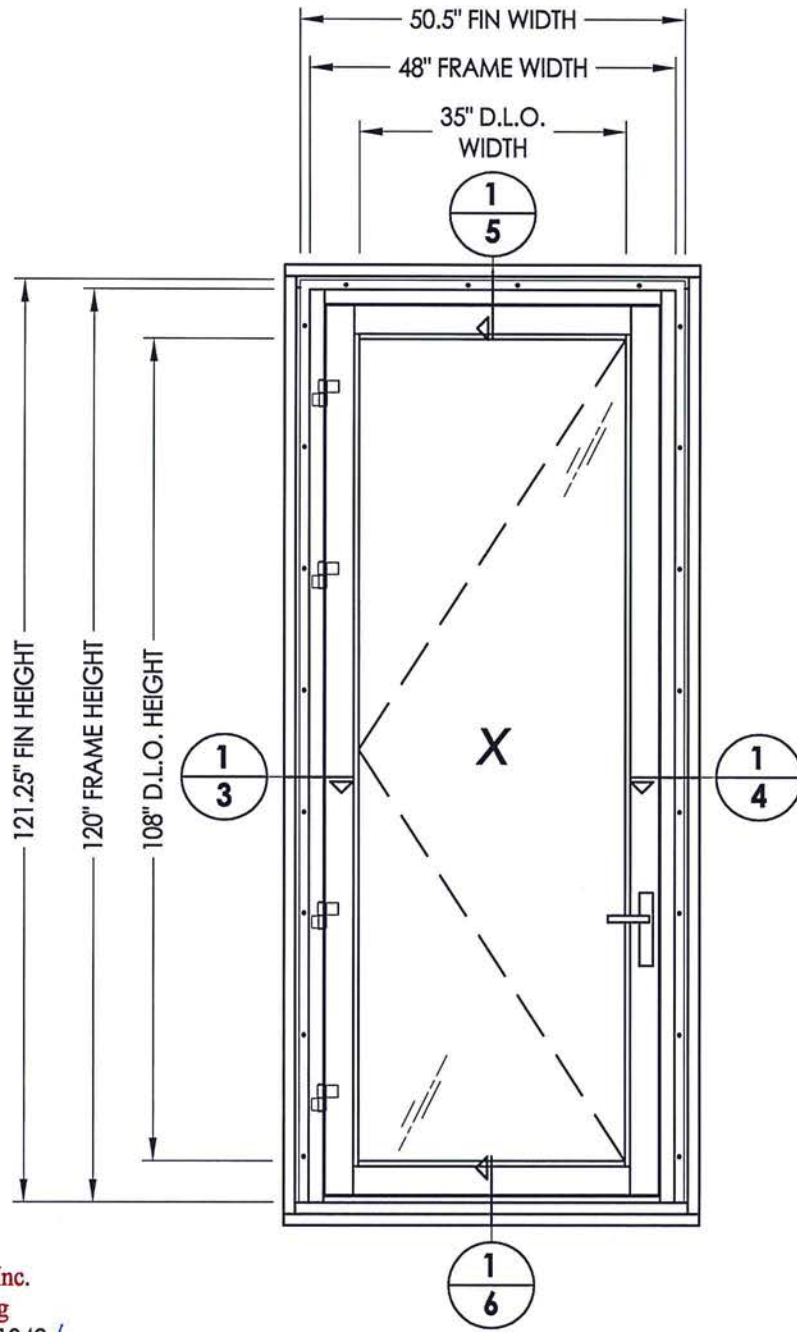

Testing Evaluation Laboratories Inc.
 Specimen Complies with Drawing
 Deviations Noted - TEL# 01991342
 Date 6/26/15 Verified by [Signature]

Note: Factory Crimped Stile

PRODUCT:		FLEETWOOD SPEC. #15	
PART OR ASSEMBLY:		TEST ELEVATIONS	
NO.	DATE	REVISIONS	BY
DATE: 3/17/15			
SCALE: N.T.S.			
DWG. BY: JK			
CHK. BY: LFS			
DRAWING NO.: L-7354			
SHEET <u>2</u> OF <u>9</u>			

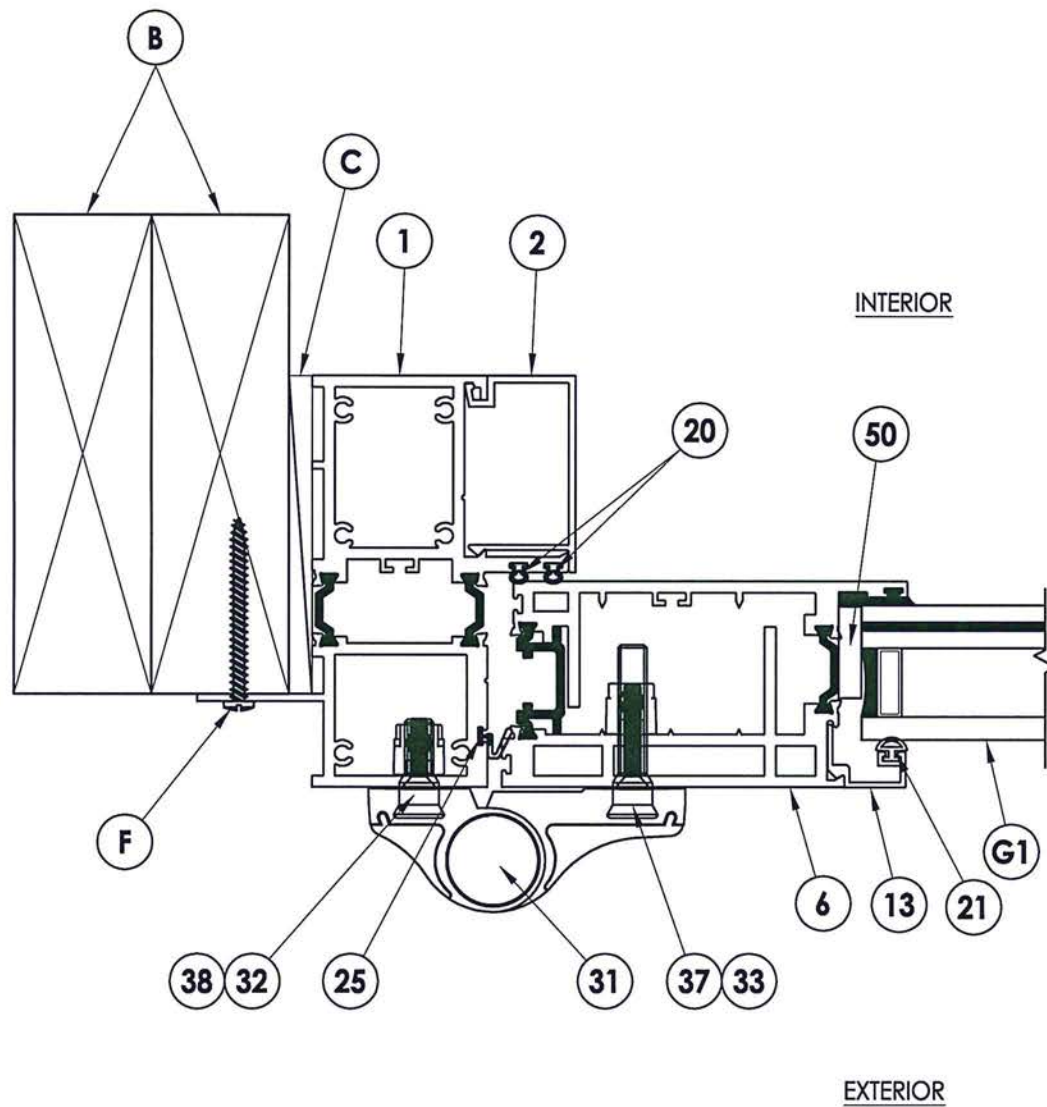

1
3 **HORIZONTAL CROSS SECTION**

Testing Evaluation Laboratories Inc.
 Specimen Complies with Drawing
 Deviations Noted - TEL# 01991342
 Date 6/26/15 Verified by *[Signature]*

PRODUCT: FLEETWOOD SPEC. #15		PART OR ASSEMBLY: HORIZONTAL CROSS SECTIONS	
		NO.	DATE
			BY
			REVISIONS
<p>RW BUILDING CONSULTANTS, INC. 813.659.9197</p>			
DATE: 3/17/15			
SCALE: N.T.S.			
DWG. BY: JK			
CHK. BY: LFS			
DRAWING NO.: L-7354			
SHEET 3 OF 9			

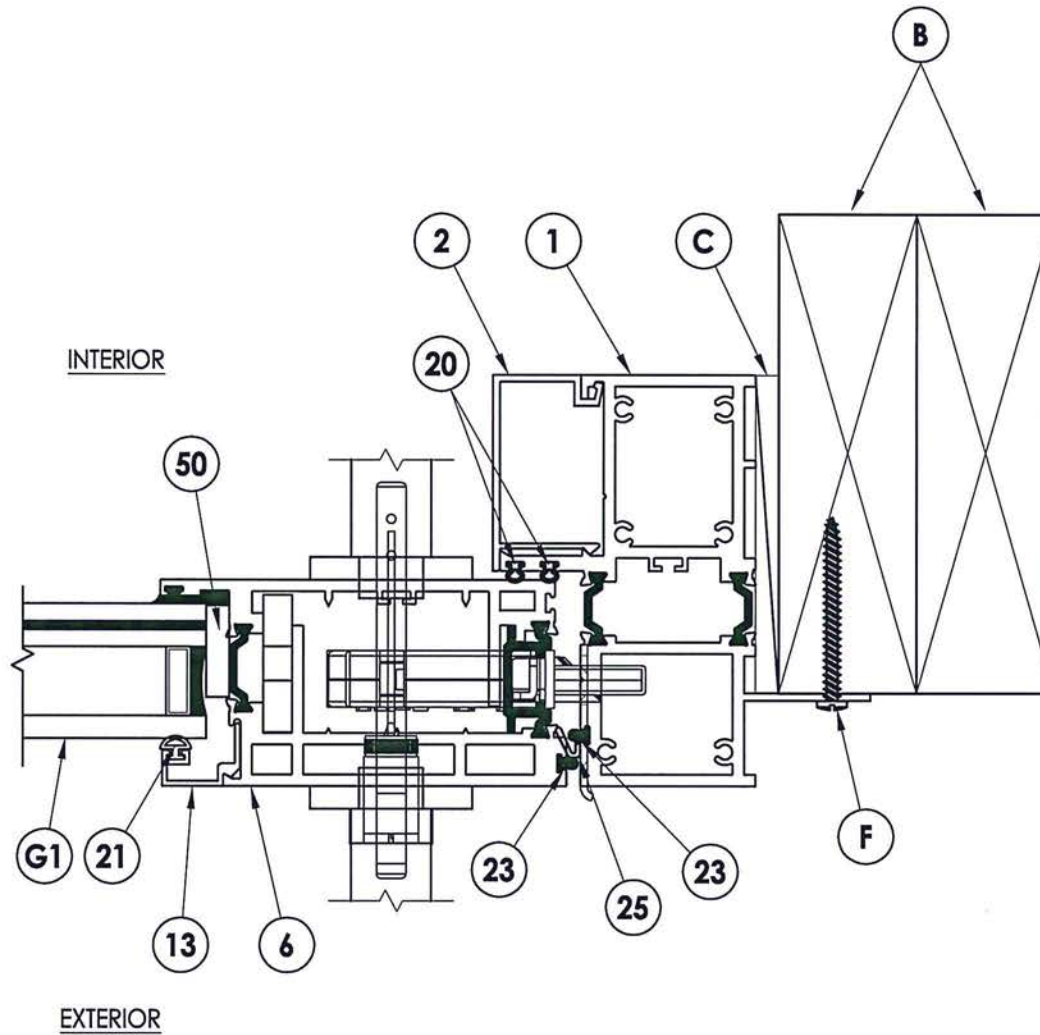

1
4 **HORIZONTAL CROSS SECTION**

Testing Evaluation Laboratories Inc.
 Specimen Complies with Drawing
 Deviations Noted - TEL# 01991342
 Date 6/26/15 Verified by *[Signature]*

PRODUCT: FLEETWOOD SPEC. #15		PART OR ASSEMBLY: HORIZONTAL CROSS SECTIONS	
NO.	DATE	REVISIONS	BY
 RW BUILDING CONSULTANTS, INC. 813.659.9197			
DATE: 3/17/15			
SCALE: N.T.S.			
DWG. BY: JK			
CHK. BY: LFS			
DRAWING NO.: L-7354			
SHEET 4 OF 9			

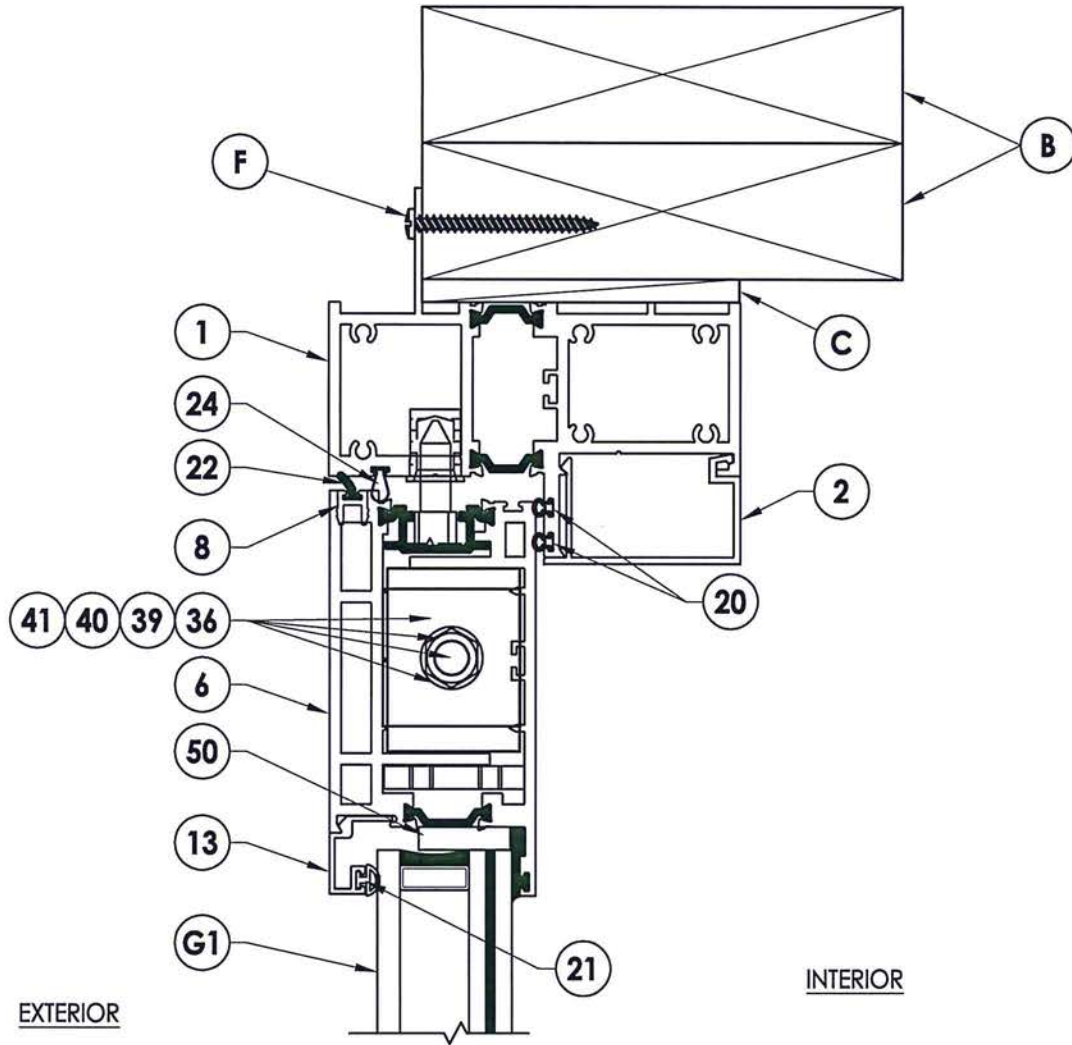

EXTERIOR

INTERIOR

1
5 **VERTICAL CROSS SECTION**

Testing Evaluation Laboratories Inc.
 Specimen Complies with Drawing
 Deviations Noted - TEL# 0199.1342
 Date 6/26/15 Verified by *[Signature]*

PRODUCT: FLEETWOOD SPEC. #15		PART OR ASSEMBLY: VERTICAL CROSS SECTIONS	
NO.	DATE	REVISIONS	BY
DATE: 3/17/15			
SCALE: N.T.S.			
DWG. BY: JK			
CHK. BY: LFS			
DRAWING NO.: L-7354			
SHEET 5 OF 9			

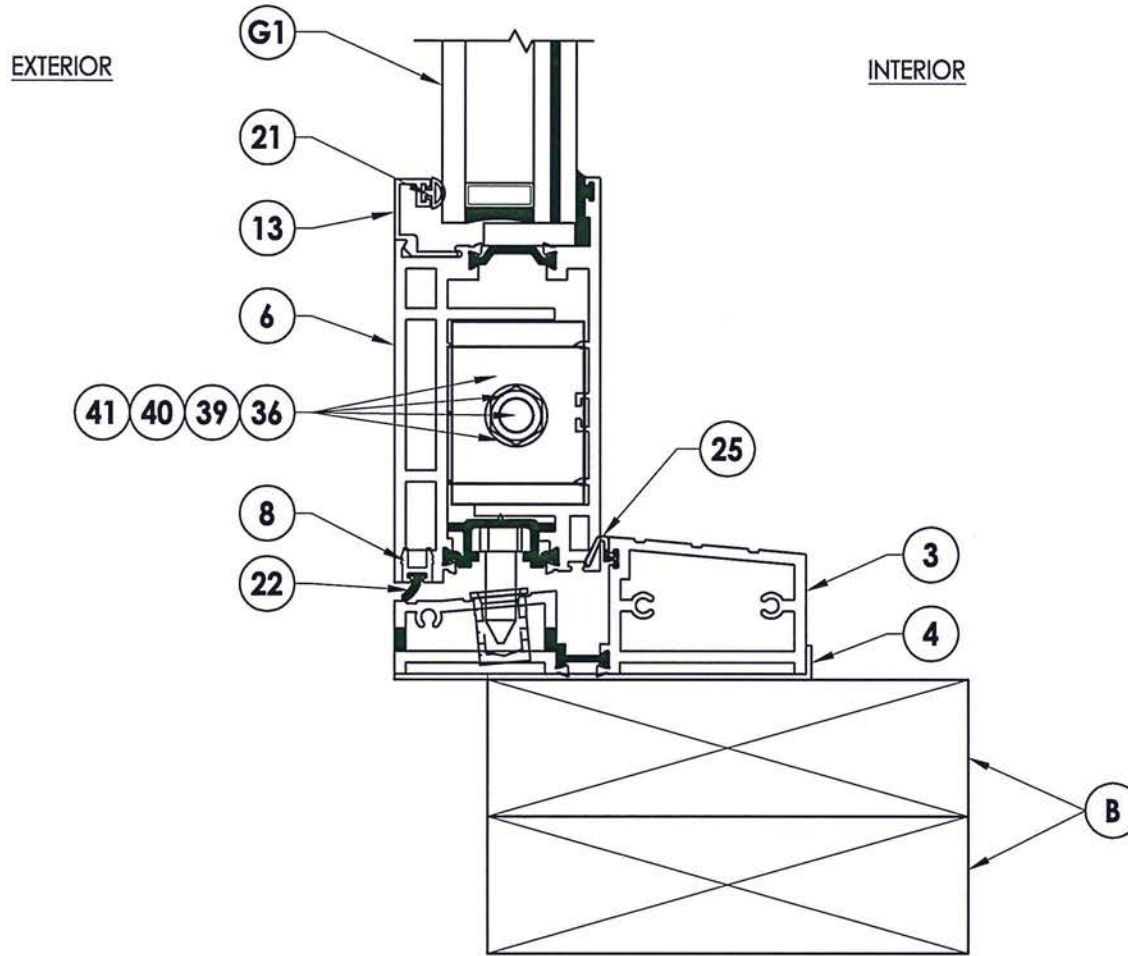

1
6 **VERTICAL CROSS SECTION**

Testing Evaluation Laboratories Inc.
 Specimen Complies with Drawing
 Deviations Noted - TEL# 01991342
 Date 6/26/15 Verified by [Signature]

PRODUCT: FLEETWOOD SPEC. #15		PART OR ASSEMBLY: VERTICAL CROSS SECTIONS	
		NO.	DATE
		BY	REVISIONS
DATE: 3/17/15			
SCALE: N.T.S.			
DWG. BY: JK			
CHK. BY: LFS			
DRAWING NO.: L-7354			
SHEET 6 OF 9			

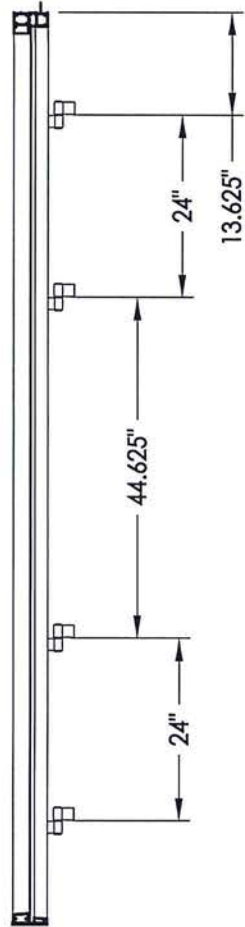

HINGE DETAIL

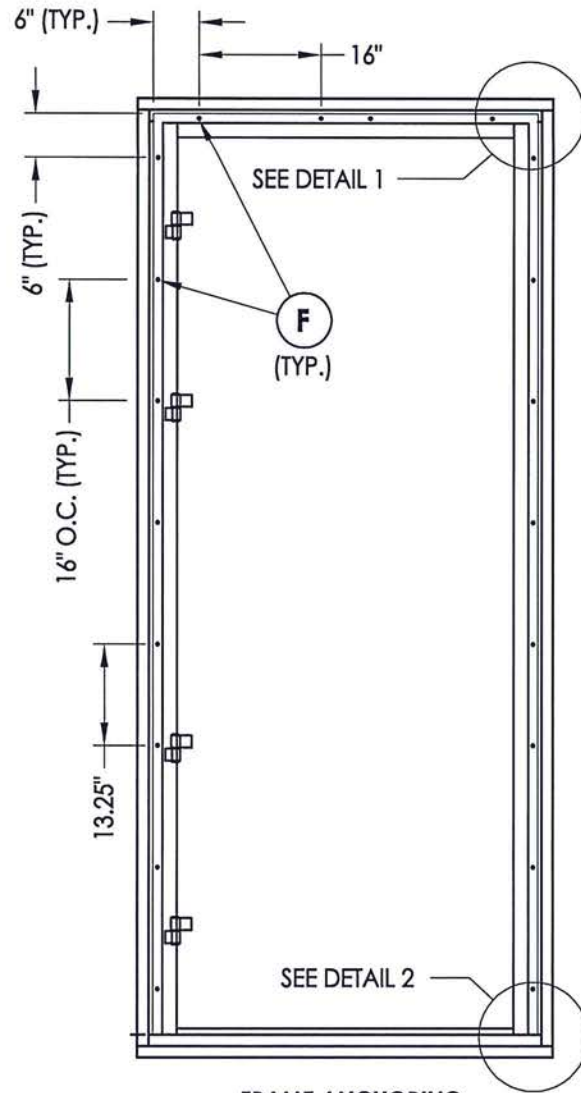

FRAME ANCHORING
(2X buck installation)

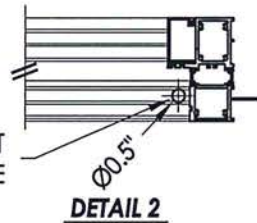

DETAIL 2

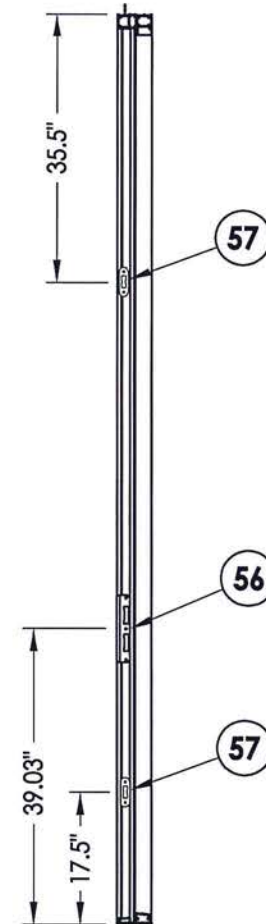

STRIKE PLATE DETAIL

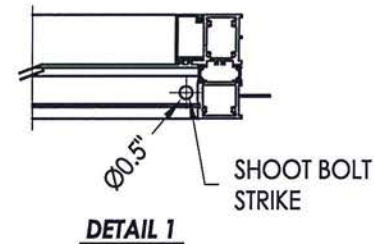

DETAIL 1

Testing Evaluation Laboratories Inc.
Specimen Complies with Drawing
Deviations Noted - TEL# 01991342
Date 6/26/15 Verified by *[Signature]*

PRODUCT: FLEETWOOD SPEC. #15		PART OR ASSEMBLY: TEST ELEVATIONS	
NO.		DATE	BY
NO.		DATE	REVISIONS
DATE: 3/17/15			
SCALE: N.T.S.			
DWG. BY: JK			
CHK. BY: LFS			
DRAWING NO.: L-7354			
SHEET 7 OF 9			

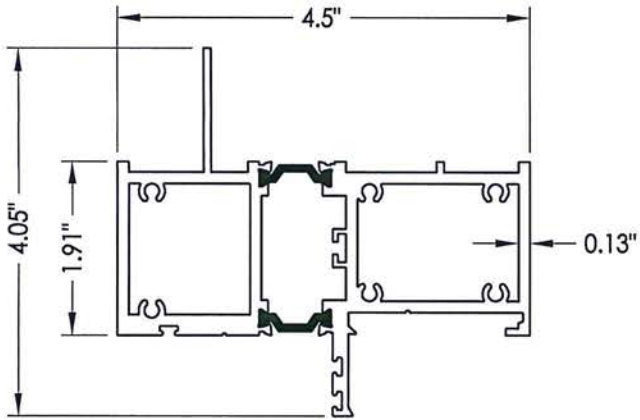

1 BLOCK HEAD & JAMBS

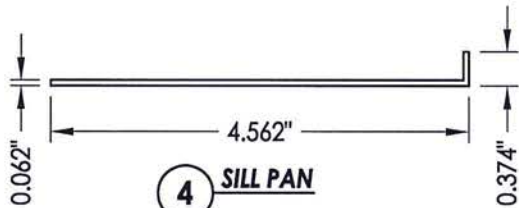

4 SILL PAN

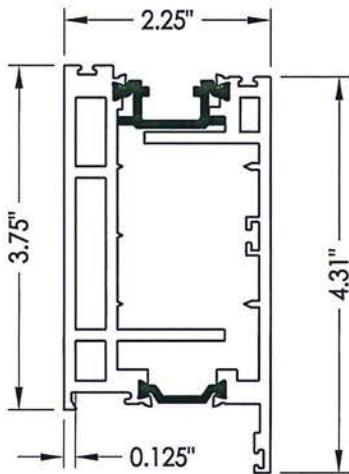

6 SASH

Testing Evaluation Laboratories Inc.
 Specimen Complies with Drawing
 Deviations Noted - TEL# 01991342
 Date 6/26/15 Verified by *[Signature]*

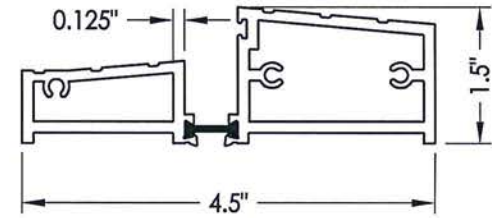

3 OUT-SWING SILL

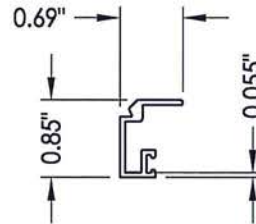

13 1.5" GLASS STOP

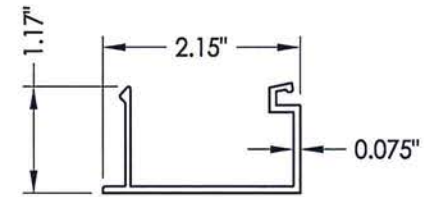

2 FRAME SNAP-IN

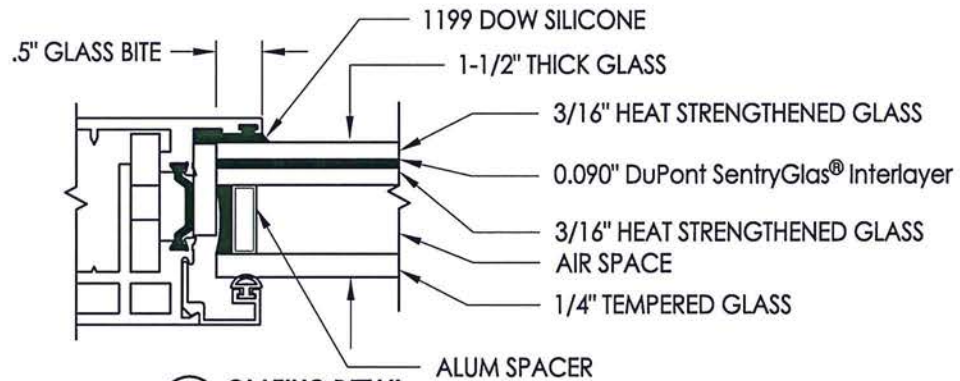

G1 GLAZING DETAIL

PRODUCT: FLEETWOOD SPEC. #15		PART OR ASSEMBLY: COMPONENTS AND GLAZING DETAIL	
NO.	DATE	REVISIONS	BY
DATE: 3/17/15			
SCALE: N.T.S.			
DWG. BY: JK			
CHK. BY: LFS			
DRAWING NO.: L-7354			
SHEET 8 OF 9			

