



Testing Evaluation Laboratories, Inc.

2002 Wood Court Suite 1 – Plant City, FL 33563
Phone: 813-754-9887

ASTM E 1886-05 / ASTM E 1996-09
Missile Level "D" (Includes Wind Zone 4)

TEST REPORT SUMMARY

Test Report Issued To:

Fleetwood Windows and Doors
1 Fleetwood Way
Corona, CA 92879

3900-T Side Hinged Doors

Title of Test	Results	
	Specimen 6a 169.00 x 120.00 OXO – Outswing (3800-T Sidelite)	Specimens 6c, 6d, 6e 169.00 x 120.00 OXO – Outswing (Sash Sidelite)
Impact	Pass	Pass
Fatigue Load Cycling	+50.0/- 55.0 psf	+65.0/- 65.0 psf

Reference should be made to Report No. TEL 01991349 for complete test specimen description and data. For corresponding data regarding AAMA/WDMA/CSA 101/I.S./2/A440-08 and A440-11 (A440S1-09) reference should be made to Report No. TEL 01991348.

For Testing Evaluation Laboratories, Inc.

Vivian K. Wright,
President



Testing Evaluation Laboratories, Inc.

2002 Wood Court Suite 1 – Plant City, FL 33563
Phone: 813-754-9887

TEST RESULTS

IAS Lab Certification Number: TL-299

Report No: TEL 01991349
Test Dates: March 16, 2015
through April 3, 2015
Report Date: June 26, 2015

Issued to:

Fleetwood Windows and Doors
1 Fleetwood Way
Corona, CA 92879

Project Summary: Testing Evaluation Laboratories, Inc. (TEL) was contracted by Fleetwood Windows and Doors to perform tests on the 3900-T Side Hinged Doors at TEL's Plant City, FL test facility.

Test specimen descriptions and results are reported herein.

Test Specifications: The test specimens were evaluated in accordance with the following:

ASTM E 1886-05 / ASTM E 1996-09
Missile Level "D" (Includes Wind Zone 4)

Test Specimen Description:

Series / Model: 3900-T Side Hinged Doors
Type: Aluminum Side Hinged Doors
Overall Size: 169.00" x 120.00" – All Specimens – (OXO)
Daylight Opening: 35.00" x 108.00" – Door Panel – All Specimens
57.00" x 117.00" – 3800-T Sidelite– Specimen 6 and 6a
47.00" x 108.00" – Sash Sidelite – All Specimens
Glazing Details: See attached drawings for glazing details.
Frame Material: Aluminum
Finish: Mill Finish

For Tested Elevation, Vertical Cross Sections, Horizontal Cross Sections, Components, Frame Anchoring, Glazing Detail and Bill of Materials See Attached Drawing numbers L-7349 and L-7349A.

IMPACT AND CYCLING TESTS

Specimen 6a – 169.00" x 120.00" – Outswing Door with (1) 3800-T Sidelite and (1) Sash Sidelite – OXO

ASTM E1886-05/1996-09 – Large Missile Impact (2 x 4 Southern Yellow Pine)

Cond. Temp Of Specimen	Missile Level	Missile Weight	Missile Length	Muzzle Distance From Specimen
77°F	D	9.0 lbs, 0 oz.	8'-1/4"	17'0"

Impact Location	Results	X - Measurement	Y - Measurement	Speed
1	Pass	31.25 "	60.25 "	50.1 fps
2	Pass	53.50"	8.00"	50.0 fps
3	Pass	61.75"	60.50"	50.1 fps
4	Pass	85.75"	60.00"	50.1 fps
5	Pass	97.25 "	11.50"	50.0 fps
<p>Orientation of Missile at Impact was within +/-5° of horizontal. None of the impacts penetrated the specimens. "X" measurement is from the left edge of test specimen. "Y" measurement is from the bottom edge of test specimen.</p>				

ASTM E1886-05/1996-09 – Fatigue Load Cycling Design Pressure +50.0 psf / - 55.0 psf

Positive % of Test Load	Positive Pressure Range (psf)	Number Of Cycles	Average Cycle Time (Sec)
20% to 50%	10.0 to 25.0	3500	1.33
0% to 60%	0.0 to 30.0	300	1.95
50% to 80%	25.0 to 40.0	600	1.32
30% to 100%*	15.0 to 50.0	100	1.75

Negative % of Test Load	Negative Pressure Range (psf)	Number Of Cycles	Average Cycle Time (Sec)
30% to 100%*	16.5 to 55.0	50	1.71
50% to 80%	27.5 to 44.0	1050	1.21
0% to 60%	0.0 to 33.0	50	2.13
20% to 50%	11.0 to 27.5	3350	1.17

*Active Panel deflected 1.75" from original plane at 100% Positive load and 2.25" from original plane at 100% Negative load. At the completion of cycles the door panel was operable. There were no tears in the film. In our opinion, the tape and film used to seal for air leakage did not influence the results of the test.

James Hayhurst, Test Technician

IMPACT AND CYCLING TESTS

Specimen 6c – 169.00" x 120.00" – Outswing Door with Sash Sidelites – OXO

ASTM E1886-05/1996-09 – Large Missile Impact (2 x 4 Southern Yellow Pine)

Cond. Temp Of Specimen	Missile Level	Missile Weight	Missile Length	Muzzle Distance From Specimen
77°F	D	9.0 lbs, 1 oz.	8'-1/2"	17'0"

Impact Location	Results	X - Measurement	Y - Measurement	Speed
1	Pass	30.00"	60.00"	50.0 fps
2	Pass	60.25"	61.00"	49.9 fps
3	Pass	84.50"	59.25"	50.1 fps
4	Pass	96.00"	11.50"	50.0 fps
5	Pass	47.50"	11.25"	50.1 fps
Orientation of Missile at Impact was within +/-5° of horizontal. None of the impacts penetrated the specimens. "X" measurement is from the left edge of test specimen. "Y" measurement is from the bottom edge of test specimen.				

ASTM E1886-05/1996-09 – Fatigue Load Cycling

Design Pressure +65.0 psf / - 65.0 psf

Positive % of Test Load	Positive Pressure Range (psf)	Number Of Cycles	Average Cycle Time (Sec)
20% to 50%	13.0 to 32.5	3500	1.99
0% to 60%	0.0 to 39.0	300	1.21
50% to 80%	32.5 to 52.0	600	1.31
30% to 100%*	19.5 to 65.0	100	1.41

Negative % of Test Load	Negative Pressure Range (psf)	Number Of Cycles	Average Cycle Time (Sec)
30% to 100%*	19.5 to 65.0	50	1.65
50% to 80%	32.5 to 52.0	1050	1.63
0% to 60%	0.0 to 39.0	50	1.99
20% to 50%	13.0 to 32.5	3350	2.29

*Active Panel deflected 2.75" from original plane at 100% Positive load and 3.00" from original plane at 100% Negative load. At the completion of cycles the door panel was operable. There were no tears in the film. In our opinion, the tape and film used to seal for air leakage did not influence the results of the test.

James Hayhurst, Test Technician

IMPACT AND CYCLING TESTS

Specimen 6d – 169.00" x 120.00" – Outswing Door with Sash Sidelites – OXO

ASTM E1886-05/1996-09 – Large Missile Impact (2 x 4 Southern Yellow Pine)

Cond. Temp Of Specimen	Missile Level	Missile Weight	Missile Length	Muzzle Distance From Specimen
77°F	D	9.0 lbs, 1 oz.	8'-1/2"	17'0"

Impact Location	Results	X - Measurement	Y - Measurement	Speed
1	Pass	47.25"	11.375"	50.0 fps
2	Pass	95.75"	11.50"	50.0 fps
3	Pass	84.25"	59.50"	50.1 fps
4	Pass	60.25"	60.50"	49.9 fps
5	Pass	30.25"	59.50"	50.0 fps
Orientation of Missile at Impact was within +/-5° of horizontal. None of the impacts penetrated the specimens. "X" measurement is from the left edge of test specimen. "Y" measurement is from the bottom edge of test specimen.				

ASTM E1886-05/1996-09 – Fatigue Load Cycling Design Pressure +65.0 psf / - 65.0 psf

Positive % of Test Load	Positive Pressure Range (psf)	Number Of Cycles	Average Cycle Time (Sec)
20% to 50%	13.0 to 32.5	3500	1.99
0% to 60%	0.0 to 39.0	300	2.29
50% to 80%	32.5 to 52.0	600	2.31
30% to 100%*	19.5 to 65.0	100	2.74

Negative % of Test Load	Negative Pressure Range (psf)	Number Of Cycles	Average Cycle Time (Sec)
30% to 100%*	19.5 to 65.0	50	2.99
50% to 80%	32.5 to 52.0	1050	2.25
0% to 60%	0.0 to 39.0	50	1.89
20% to 50%	13.0 to 32.5	3350	1.71

*Active Panel deflected 3.625" from original plane at 100% Positive load and 4.00" from original plane at 100% Negative load. At the completion of cycles the door panel was operable. There were no tears in the film. In our opinion, the tape and film used to seal for air leakage did not influence the results of the test.

James Hayhurst, Test Technician

IMPACT AND CYCLING TESTS

Specimen 6e – 169.00" x 120.00" – Outswing Door with Sash Sidelites – OXO

ASTM E1886-05/1996-09 – Large Missile Impact (2 x 4 Southern Yellow Pine)

Cond. Temp Of Specimen	Missile Level	Missile Weight	Missile Length	Muzzle Distance From Specimen
77°F	D	9.0 lbs, 1 oz.	8'-1/2"	17'0"

Impact Location	Results	X - Measurement	Y - Measurement	Speed
1	Pass	30.00"	59.75"	49.9 fps
2	Pass	60.38"	60.50"	50.0 fps
3	Pass	84.625"	59.50"	50.0 fps
4	Pass	73.00"	107.50"	50.1 fps
5	Pass	12.50"	107.25"	50.0 fps
Orientation of Missile at Impact was within +/-5° of horizontal. None of the impacts penetrated the specimens. "X" measurement is from the left edge of test specimen. "Y" measurement is from the bottom edge of test specimen.				

ASTM E1886-05/1996-09 – Fatigue Load Cycling

Design Pressure +65.0 psf / - 65.0 psf

Positive % of Test Load	Positive Pressure Range (psf)	Number Of Cycles	Average Cycle Time (Sec)
20% to 50%	13.0 to 32.5	3500	2.01
0% to 60%	0.0 to 39.0	300	2.11
50% to 80%	32.5 to 52.0	600	2.59
30% to 100%*	19.5 to 65.0	100	2.87

Negative % of Test Load	Negative Pressure Range (psf)	Number Of Cycles	Average Cycle Time (Sec)
30% to 100%*	19.5 to 65.0	50	2.91
50% to 80%	32.5 to 52.0	1050	2.53
0% to 60%	0.0 to 39.0	50	2.01
20% to 50%	13.0 to 32.5	3350	1.89

*Active Panel deflected 3.625" from original plane at 100% Positive load and 4.00" from original plane at 100% Negative load. At the completion of cycles the door panel was operable. There were no tears in the film. In our opinion, the tape and film used to seal for air leakage did not influence the results of the test.

James Hayhurst, Test Technician

Conditions, Terms, and General Notes Regarding These Tests

The product tested Has Been compared to the detailed drawing, bill of materials and fabrication information supplied by the client so named herein. Our analysis, which includes dimensional and component description comparisons, indicate the tested product and engineering information supplied by the client "Are Equivalent". The report and representative samples will be retained for four years from the date of initial test.

These test results were obtained by employing all requirements of the designated test methods with no Deviations unless explicitly noted in test report. The test results and specimen supplied for testing are in compliance with the reference.

The test results are specific to the product tested by this laboratory and of the sample supplied by the client named herein, and they relate to no other product either manufactured by the client, a fabricator of the client or of the client or of installed field performance.

This test report does not constitute certification of this product, but only that the above test results were obtained using the designated test methods and they indicate compliance with the performance requirements (paragraphs as listed) of the above referenced specifications.

Testing Evaluation Laboratories, Inc. makes no opinions or endorsements regarding this product and its performance. This report may not be reproduced or quoted in partial form without the expressed written approval of Testing Evaluation Laboratories, Inc.

Testing Evaluation Laboratories, Inc.'s letter, reports, its name or insignia or mark are for the exclusive use of the client so named herein and any other use is strictly prohibited. The report, letters and the name of Testing Evaluation Laboratories, Inc., its seal or mark shall not be used in any circumstance to the general public or in any advertising.

Limitation of liability: Due diligence was used in performing the tests and reporting the results. By acceptance of this report, this client agrees to hold harmless and indemnify Testing Evaluation Laboratories, Inc., its employees, sub-contractors, officers and owners against all claims and demands of any kind whatsoever, which arise out of or in any manner connected with the performance of work referred to herein.

Testing Evaluation Laboratories, Inc.

Vivian K. Wright,
President

Revision Log

Rev No.	Date	Page(s)	Revision(s)
0	6/26/2015	NA	Original Report Issue

.3

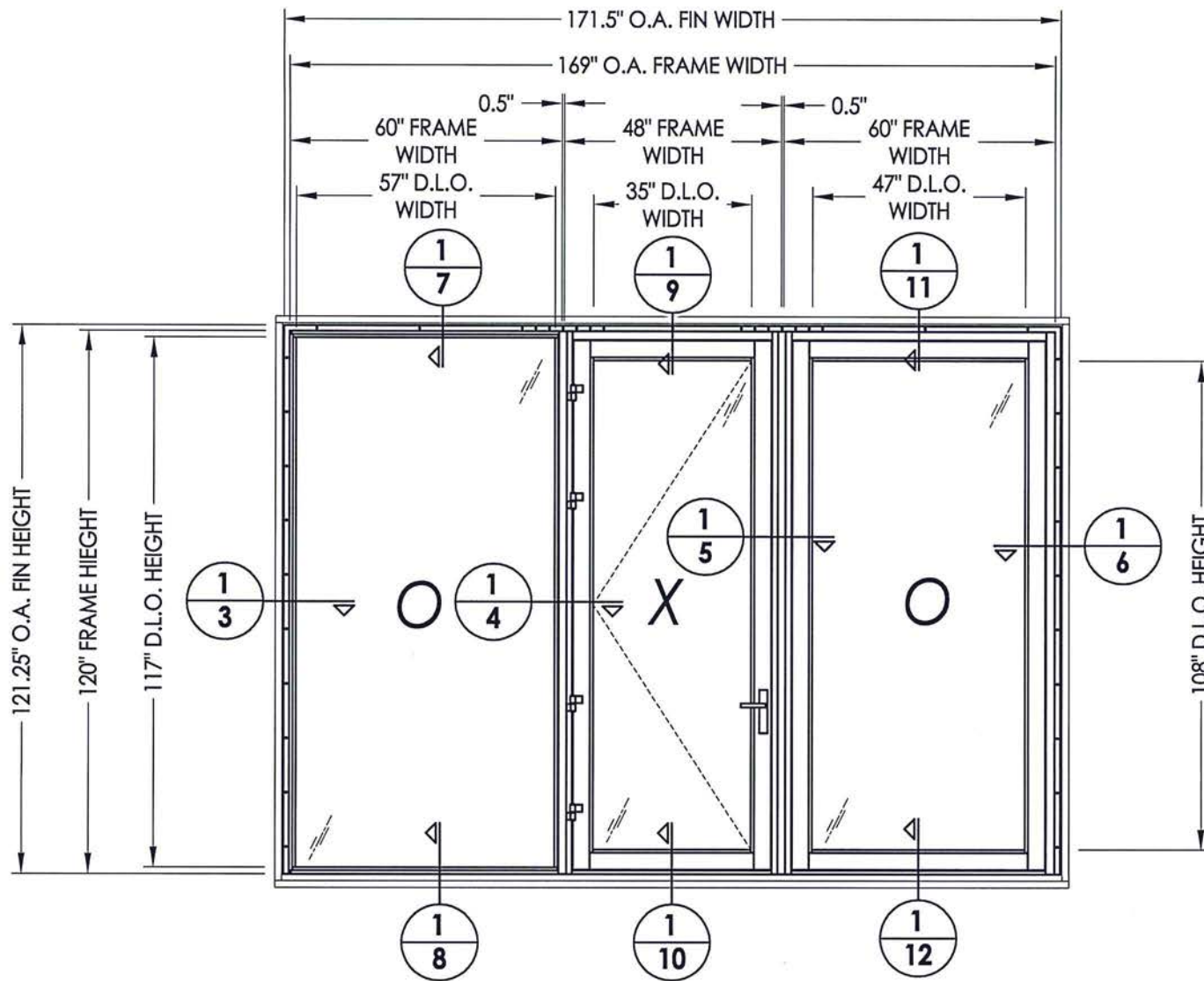

Testing Evaluation Laboratories Inc.
 Specimen Complies with Drawing
 Deviations Noted - TEL# 01991349
 Date 06/26/2015 Verified by [Signature]

PRODUCT: FLEETWOOD SPEC. 6, 6A		PART OR ASSEMBLY: TEST ELEVATIONS	
NO.	DATE	REVISIONS	BY
 RW BUILDING CONSULTANTS, INC. 813.659.9197			
DATE: 4/4/15			
SCALE: N.T.S.			
DWG. BY: JK			
CHK. BY: LFS			
DRAWING NO.: L-7349			
SHEET 2 OF 17			

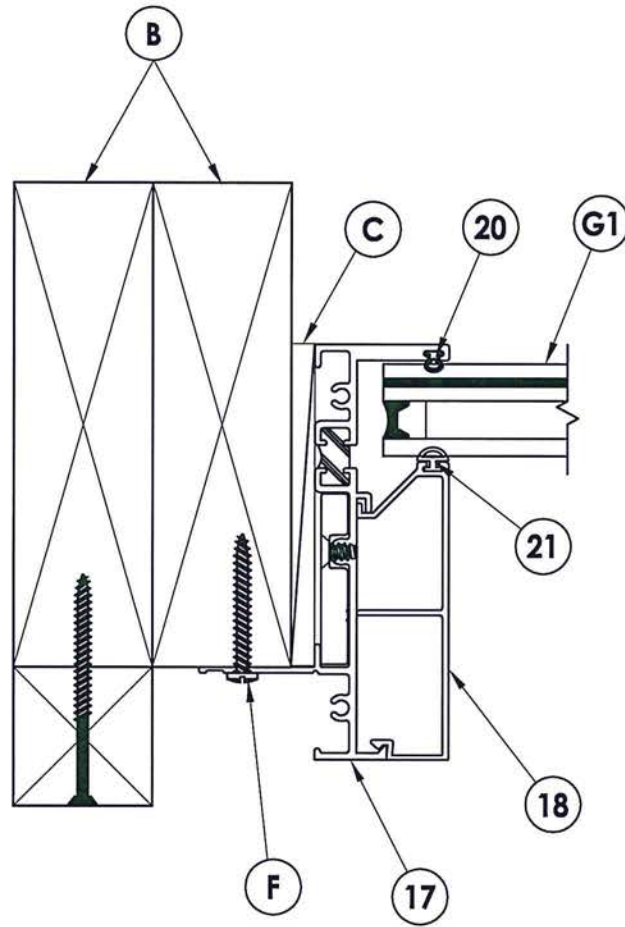

INTERIOR

EXTERIOR

Testing Evaluation Laboratories Inc.
 Specimen Complies with Drawing
 Deviations Noted - TEL# 01991349
 Date 06/26/2015 Verified by *trw*

1
3 HORIZONTAL CROSS SECTION

PRODUCT:
 FLEETWOOD
 SPEC. 6, 6A

PART OR ASSEMBLY:
 HORIZONTAL
 CROSS SECTIONS

NO.	DATE	REVISIONS	BY

RW BUILDING
 CONSULTANTS, INC.
 813.659.9197

DATE: 4/4/15

SCALE: N.T.S.

DWG. BY: JK

CHK. BY: LFS

DRAWING NO.:
 L-7349

SHEET 3 OF 17

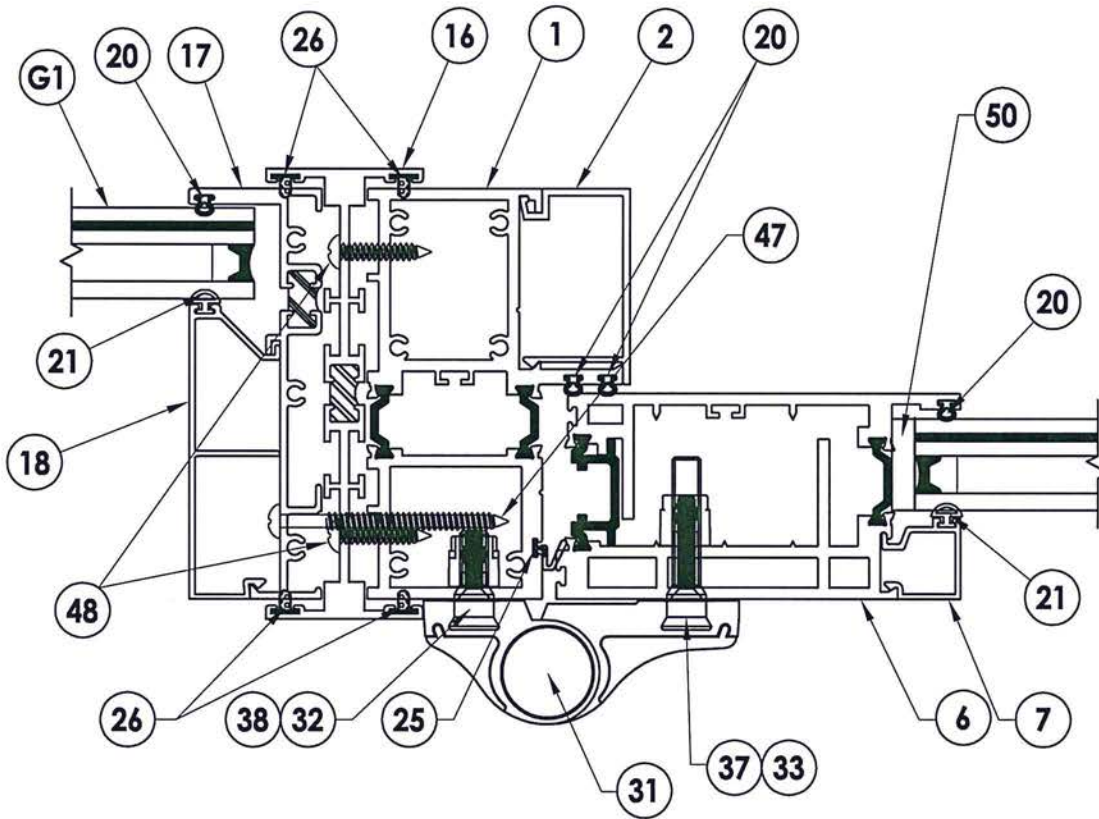

Testing Evaluation Laboratories Inc.
 Specimen Complies with Drawing
 Deviations Noted - TEL# 01991349
 Date 06/26/2015 Verified by *[Signature]*

1
4 **HORIZONTAL CROSS SECTION**

PRODUCT: FLEETWOOD SPEC. 6, 6A		PART OR ASSEMBLY: HORIZONTAL CROSS SECTIONS	
NO.	DATE	REVISIONS	BY
			
DATE: 4/4/15			
SCALE: N.T.S.			
DWG. BY: JK			
CHK. BY: LFS			
DRAWING NO.: L-7349			
SHEET 4 OF 17			

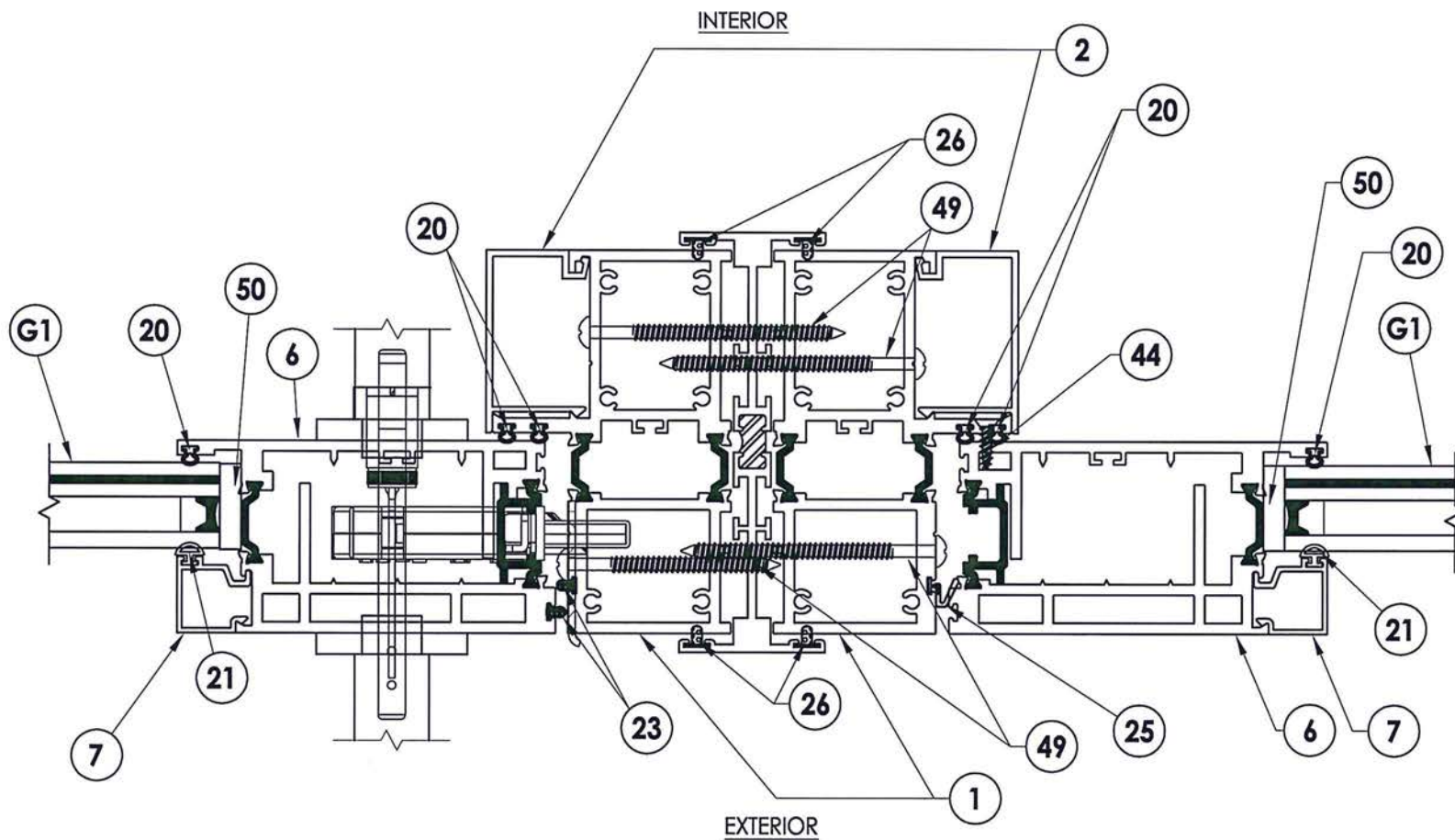

1
5 **HORIZONTAL CROSS SECTION**

Testing Evaluation Laboratories Inc.
 Specimen Complies with Drawing
 Deviations Noted - TEL# 01991349
 Date 06/26/2015 Verified by [Signature]

PRODUCT: FLEETWOOD SPEC. 6, 6A		PART OR ASSEMBLY: HORIZONTAL CROSS SECTIONS	
NO.	DATE	REVISIONS	BY
 RW BUILDING CONSULTANTS, INC. 813.659.9197			
DATE: 4/4/15			
SCALE: N.T.S.			
DWG. BY: JK			
CHK. BY: LFS			
DRAWING NO.:			
L-7349			
SHEET 5 OF 17			

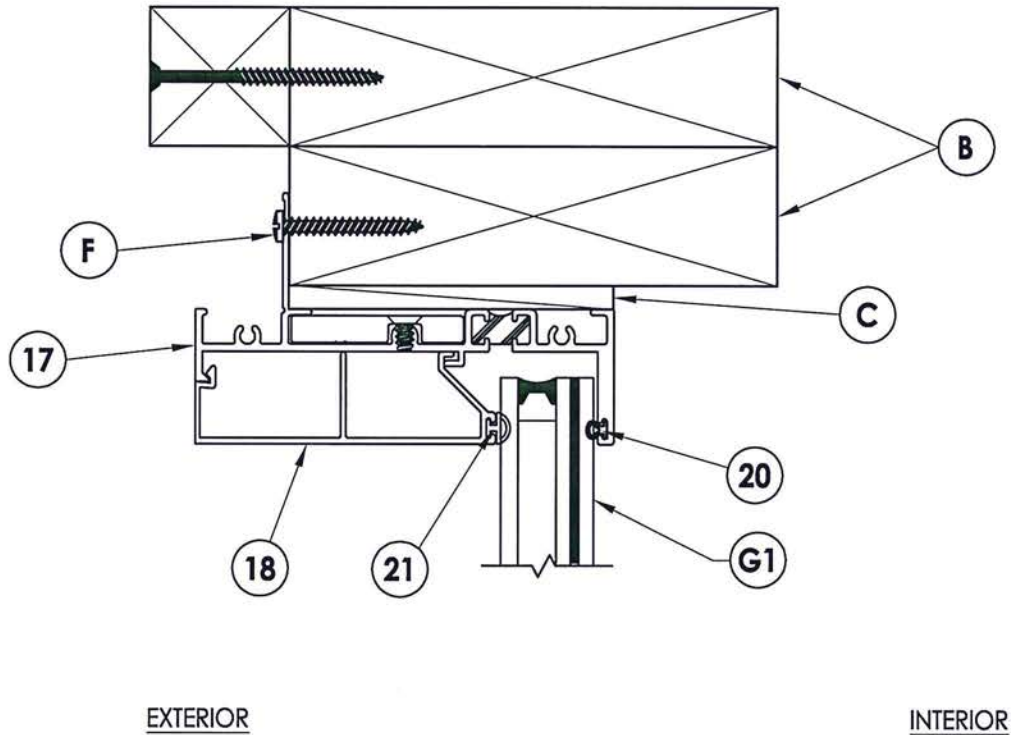

EXTERIOR

INTERIOR

1
7 **VERTICAL CROSS SECTION**

Testing Evaluation Laboratories Inc.
 Specimen Complies with Drawing
 Deviations Noted - TEL# 01991349
 Date 06/26/2015 Verified by [Signature]

PRODUCT:		FLEETWOOD SPEC. 6, 6A	
PART OR ASSEMBLY:		VERTICAL CROSS SECTIONS	
NO.	DATE	REVISIONS	BY
DATE: 4/4/15			
SCALE: N.T.S.			
DWG. BY: JK			
CHK. BY: LFS			
DRAWING NO.: L-7349			
SHEET <u>7</u> OF <u>17</u>			

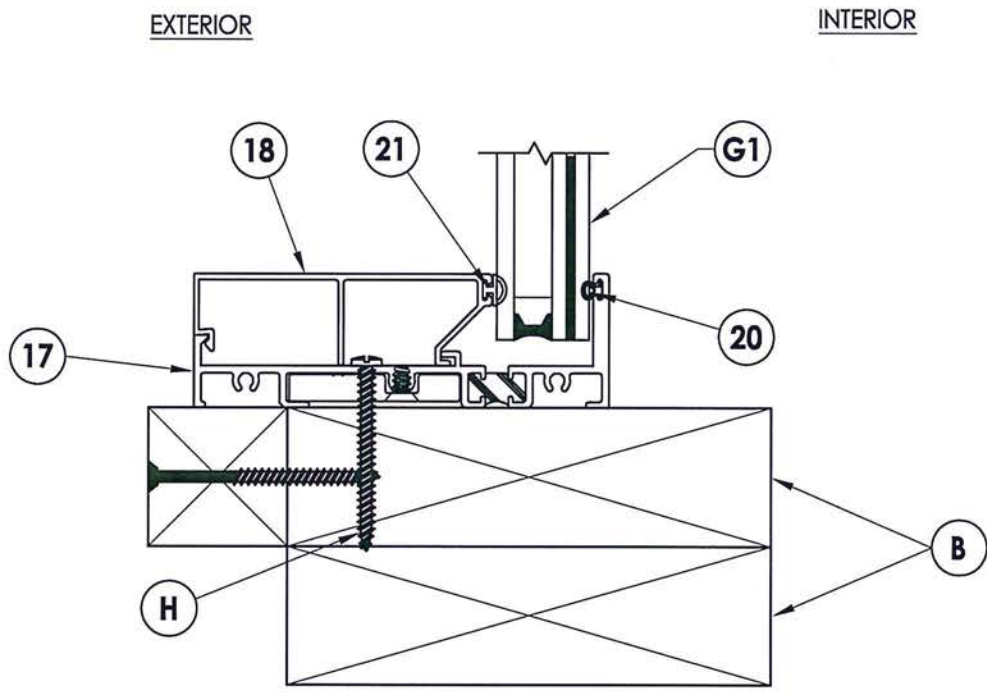

1
8 **VERTICAL CROSS SECTION**

Testing Evaluation Laboratories Inc.
 Specimen Complies with Drawing
 Deviations Noted - TEL# 01991349
 Date 06/26/2015 Verified by [Signature]

PRODUCT:		FLEETWOOD SPEC. 6, 6A	
PART OR ASSEMBLY:		VERTICAL CROSS SECTIONS	
NO.	DATE	REVISIONS	BY
 RW BUILDING CONSULTANTS, INC. 813.659.9197			
DATE:		4/4/15	
SCALE:		N.T.S.	
DWG. BY:		JK	
CHK. BY:		LFS	
DRAWING NO.:		L-7349	
SHEET		8 OF 17	

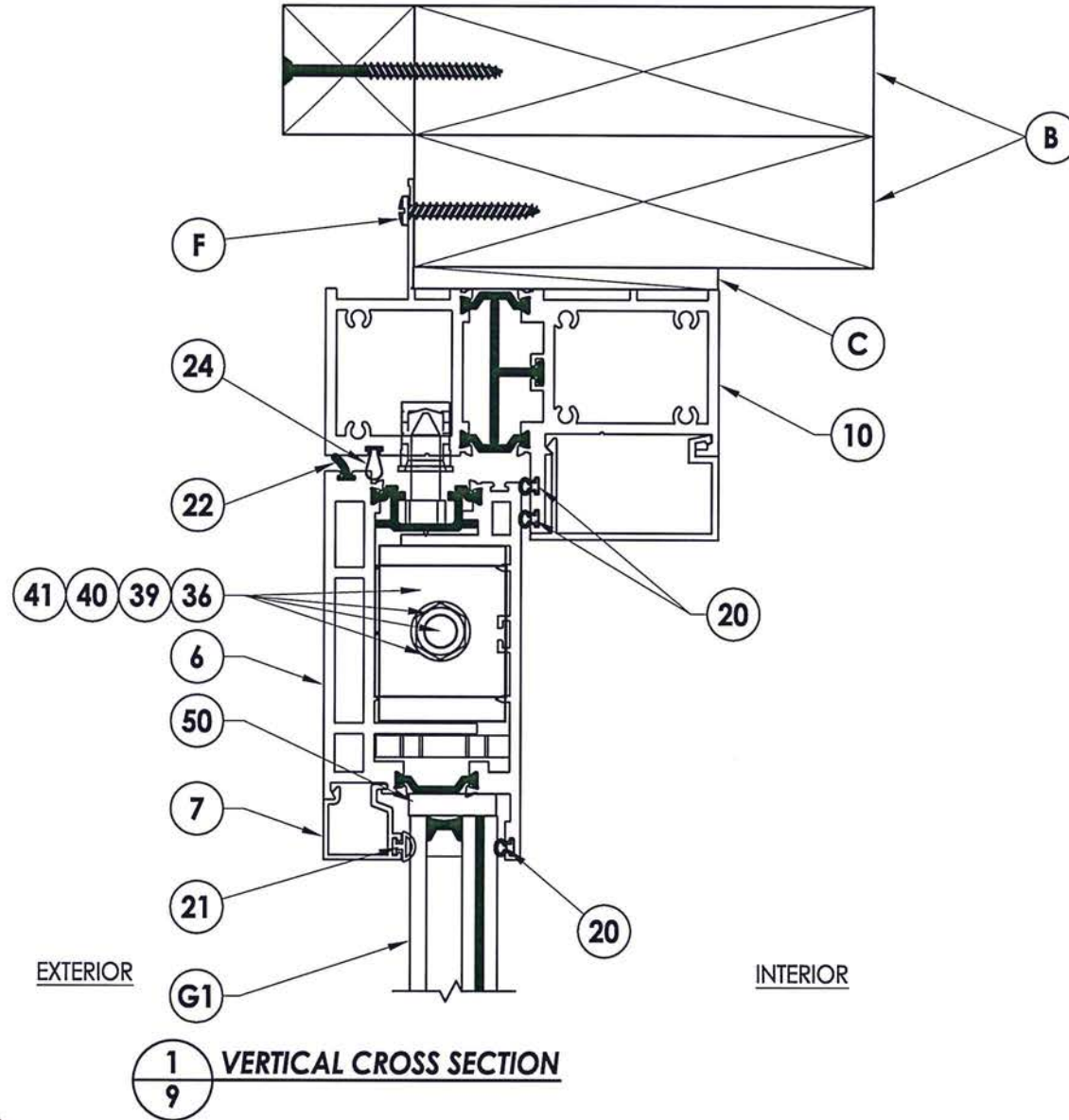

1
9 **VERTICAL CROSS SECTION**

Testing Evaluation Laboratories Inc.
 Specimen Complies with Drawing
 Deviations Noted - TEL# 01991349
 Date 06/26/2015 Verified by *[Signature]*

PRODUCT: FLEETWOOD SPEC. 6, 6A		PART OR ASSEMBLY: VERTICAL CROSS SECTIONS	
NO.	DATE	REVISIONS	BY
DATE: 4/4/15			
SCALE: N.T.S.			
DWG. BY: JK			
CHK. BY: LFS			
DRAWING NO.: L-7349			
SHEET 9 OF 17			

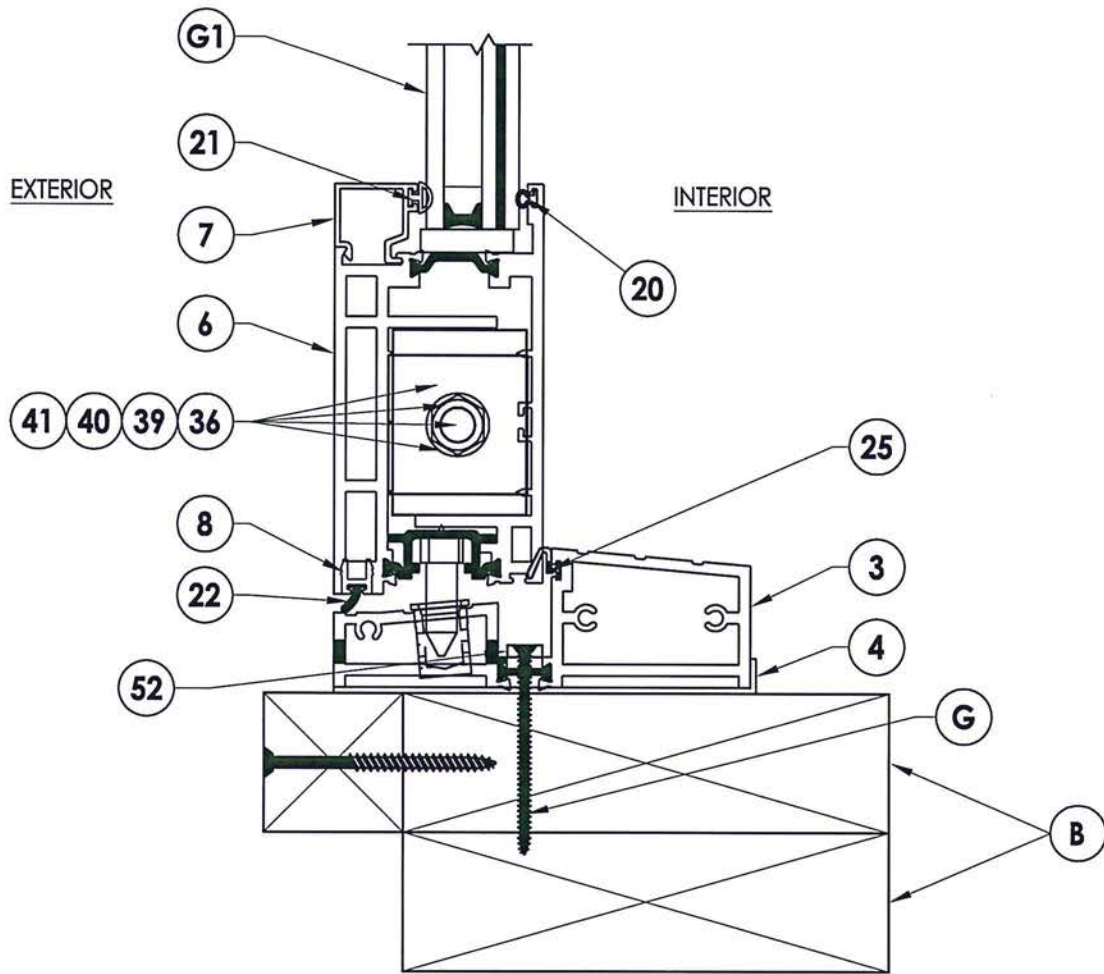

1
10 **VERTICAL CROSS SECTION**

Testing Evaluation Laboratories Inc.
 Specimen Complies with Drawing
 Deviations Noted - TEL# 01991349
 Date 06/26/2015 Verified by *[Signature]*

PRODUCT: FLEETWOOD SPEC. 6, 6A		PART OR ASSEMBLY: VERTICAL CROSS SECTIONS	
NO.	DATE	REVISIONS	BY
 RW BUILDING CONSULTANTS, INC. 813.659.9197			
DATE: 4/4/15			
SCALE: N.T.S.			
DWG. BY: JK			
CHK. BY: LFS			
DRAWING NO.: L-7349			
SHEET 10 OF 17			

EXTERIOR

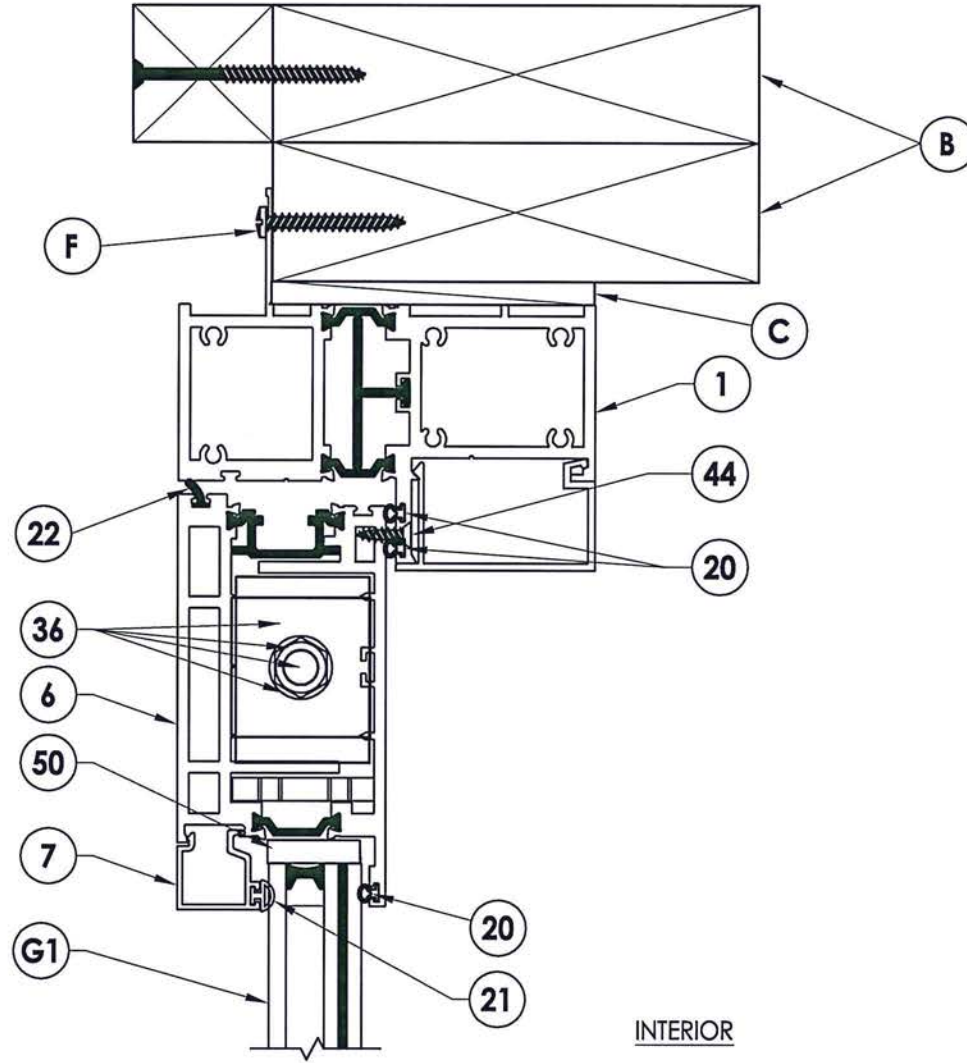

INTERIOR

1
11 **VERTICAL CROSS SECTION**

Testing Evaluation Laboratories Inc.
 Specimen Complies with Drawing
 Deviations Noted - TEL# 01991349
 Date 06/26/2015 Verified by [Signature]

PRODUCT:		FLEETWOOD SPEC. 6, 6A	
PART OR ASSEMBLY:		VERTICAL CROSS SECTIONS	
NO.	DATE	BY	REVISIONS
 RW BUILDING CONSULTANTS, INC. 813.659.9197			
DATE: 4/4/15			
SCALE: N.T.S.			
DWG. BY: JK			
CHK. BY: LFS			
DRAWING NO.:			
L-7349			
SHEET 11 OF 17			

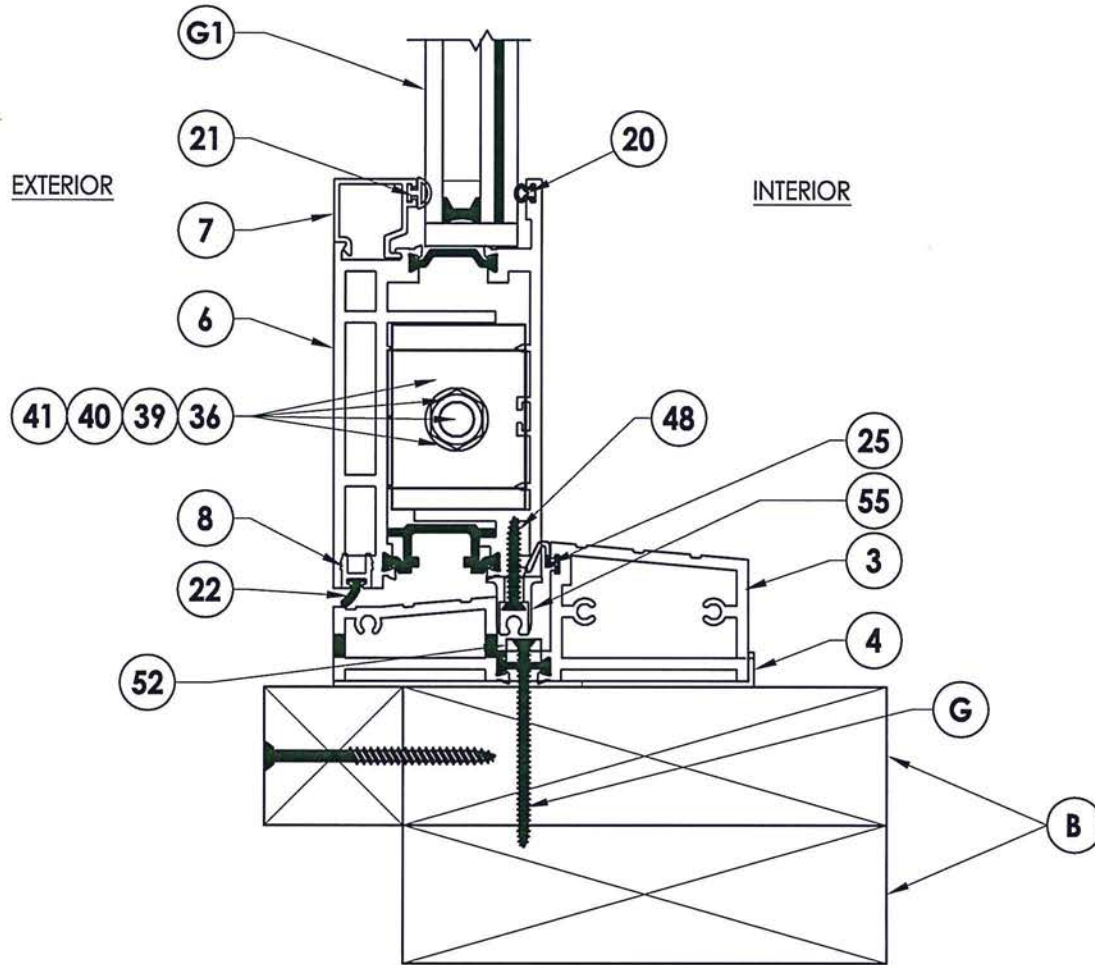

1
12 **VERTICAL CROSS SECTION**

Testing Evaluation Laboratories Inc.
 Specimen Complies with Drawing
 Deviations Noted - TEL# 01991349
 Date 06/26/2015 Verified by [Signature]

PRODUCT:		FLEETWOOD SPEC. 6, 6A	
PART OR ASSEMBLY:		VERTICAL CROSS SECTIONS	
NO.	DATE	BY	REVISIONS
DATE: 4/4/15			
SCALE: N.T.S.			
DWG. BY: JK			
CHK. BY: LFS			
DRAWING NO.:			
L-7349			
SHEET 12 OF 17			

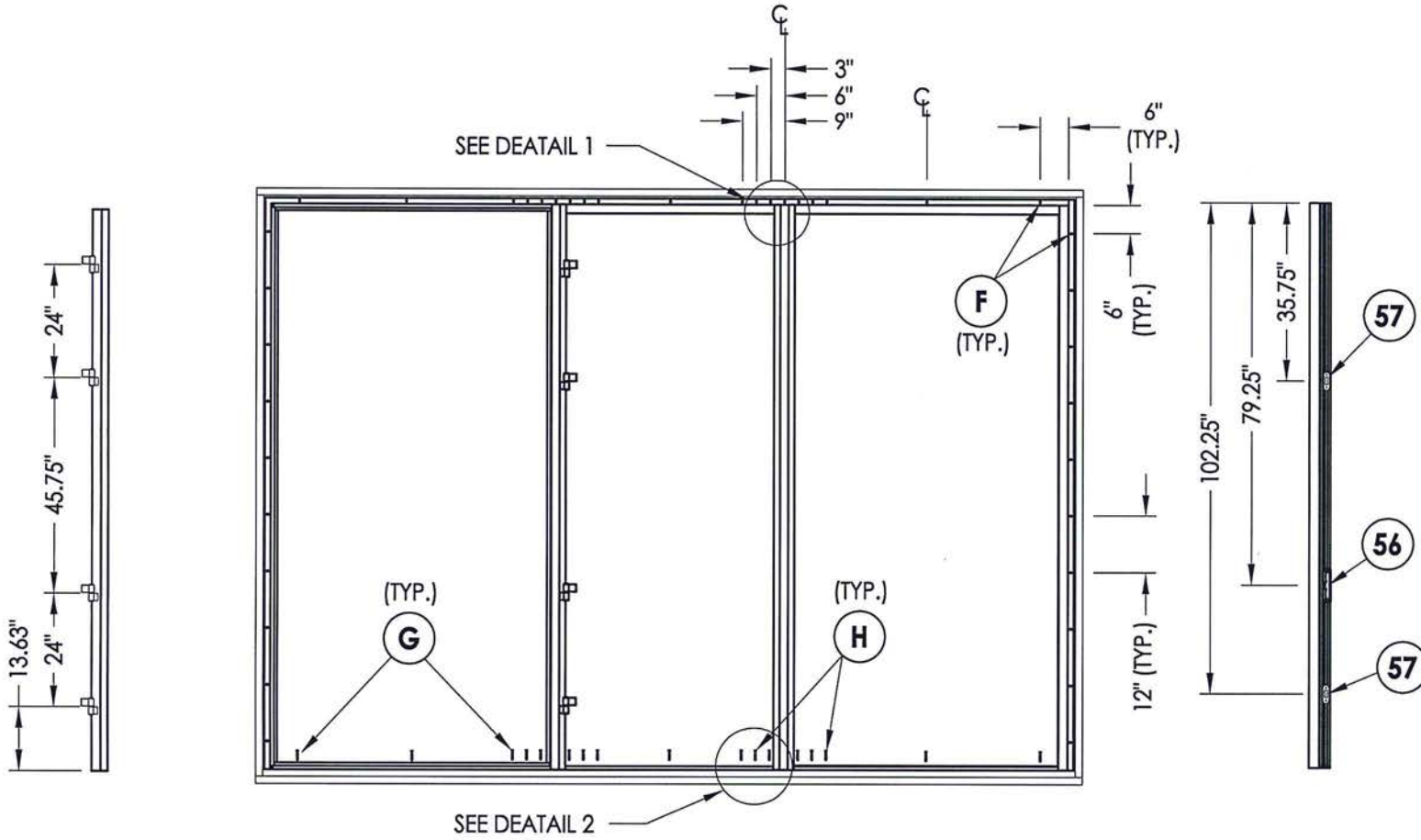

HINGE JAMB

FRAME ANCHORING
(2X buck installation)

STRIKE JAMB

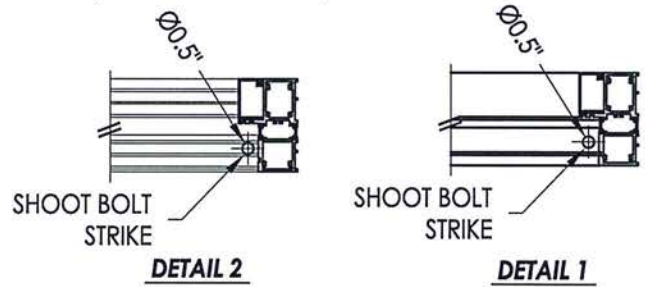

Testing Evaluation Laboratories Inc.
Specimen Complies with Drawing
Deviations Noted - TEL# 01991349
Date 06/26/2015 Verified by *[Signature]*

PRODUCT:		FLEETWOOD SPEC. 6, 6A	
PART OR ASSEMBLY:		FRAME ANCHORING	
NO.	DATE	REVISIONS	BY
DATE: 4/4/15		SCALE: N.T.S.	
DWG. BY: JK		CHK. BY: LFS	
DRAWING NO.:		L-7349	
SHEET 13 OF 17			

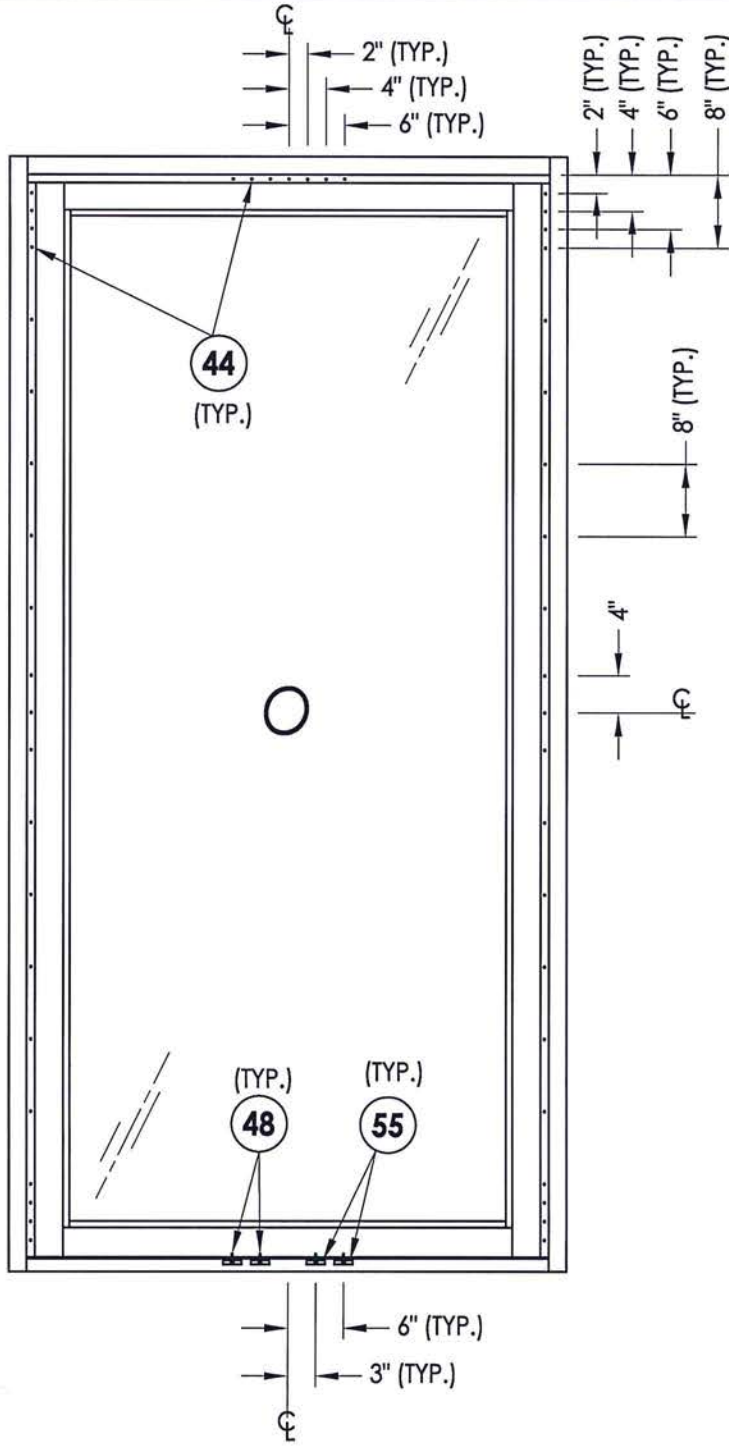

Testing Evaluation Laboratories Inc.
 Specimen Complies with Drawing
 Deviations Noted - TEL# 01991349
 Date 06/26/2015 Verified by [Signature]

PRODUCT:		FLEETWOOD SPEC. 6, 6A	
PART OR ASSEMBLY:		SIDELITE PANEL DETAIL	
NO.	DATE	BY	REVISIONS
 RW BUILDING CONSULTANTS, INC. 813.659.9197			
DATE: 4/4/15			
SCALE: N.T.S.			
DWG. BY: JK			
CHK. BY: LFS			
DRAWING NO.: L-7349			
SHEET <u>14</u> OF <u>17</u>			

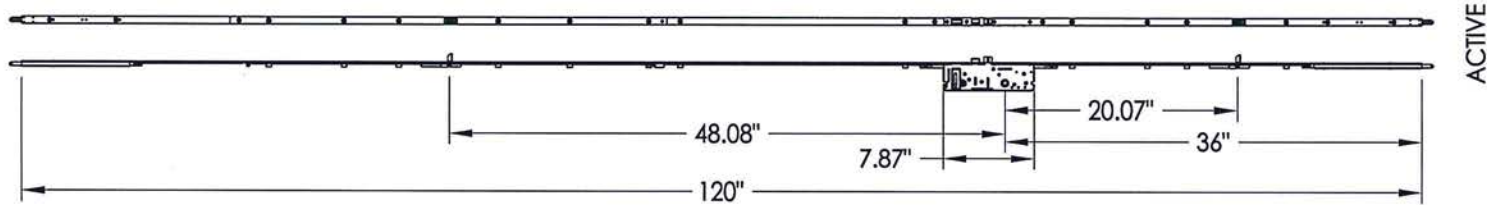

30 MULTI-POINT LOCK
TRUTH

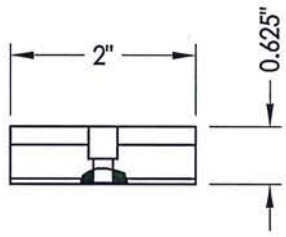

55 FIXED SILL BLOCK

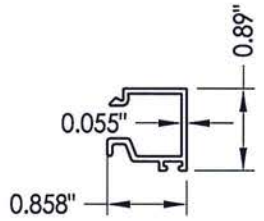

7 1" GLASS STOP

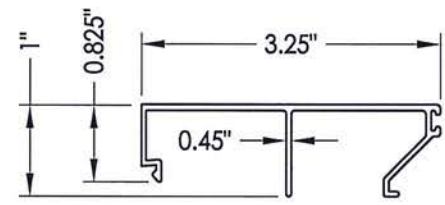

18 KONA 1" GLASS STOP

Testing Evaluation Laboratories Inc.
Specimen Complies with Drawing
Deviations Noted - TEL# 01991349
Date 06/26/2015 Verified by [Signature]

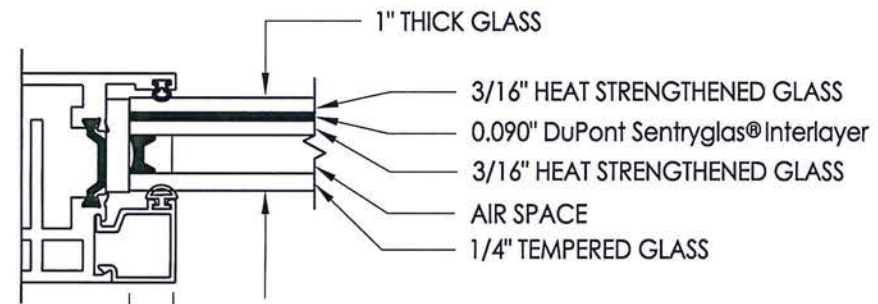

G1 GLAZING DETAIL

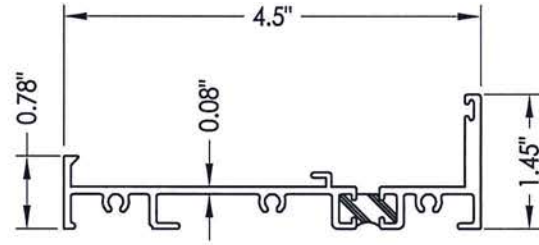

17 KONA FRAME

PRODUCT: FLEETWOOD SPEC. 6, 6A		PART OR ASSEMBLY: COMPONENTS AND GLAZING DETAIL	
NO.		DATE	BY
NO.		DATE	REVISIONS
DATE: 4/4/15		SCALE: N.T.S.	
DWG. BY: JK		CHK. BY: LFS	
DRAWING NO.: L-7349		SHEET 15 OF 17	

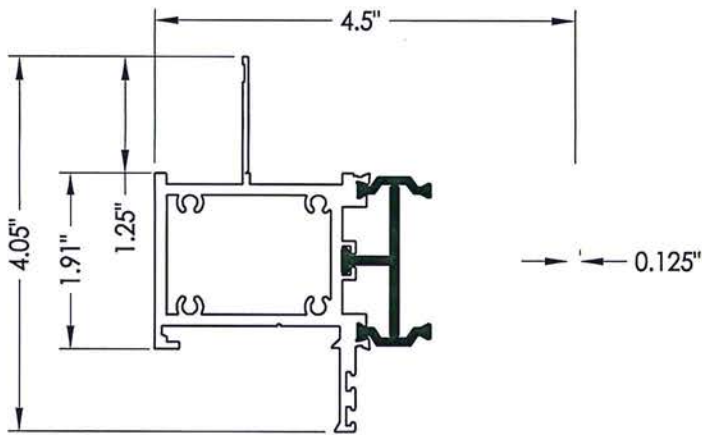

10 FRAME
(Fin)

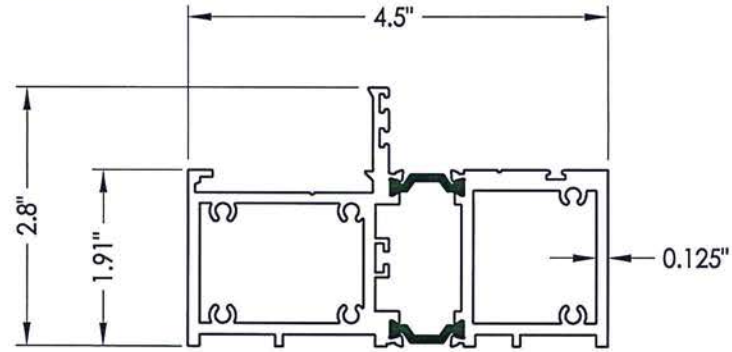

1 FRAME

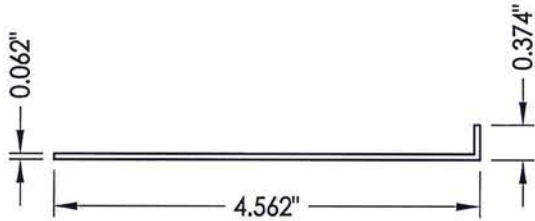

4 SILL PAN

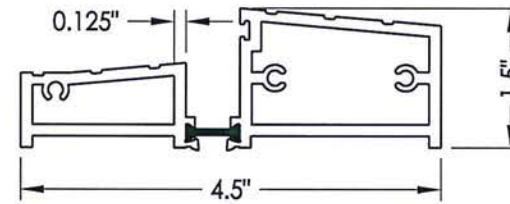

3 OUTSWING SILL

Testing Evaluation Laboratories Inc.
Specimen Complies with Drawing
Deviations Noted - TEL# 01991349
Date 06/26/2015 Verified by *[Signature]*

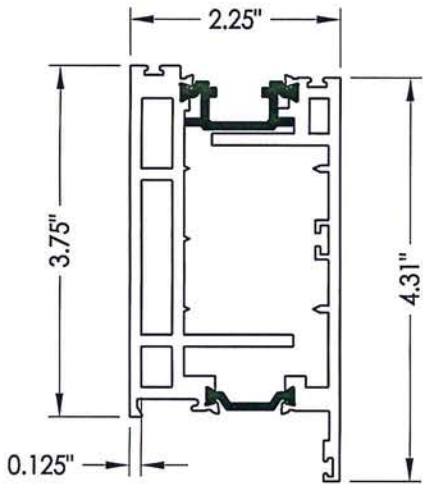

6 SASH

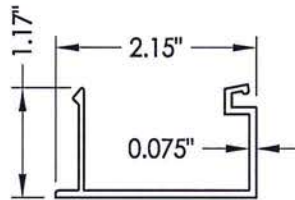

2 FRAME SNAP-IN

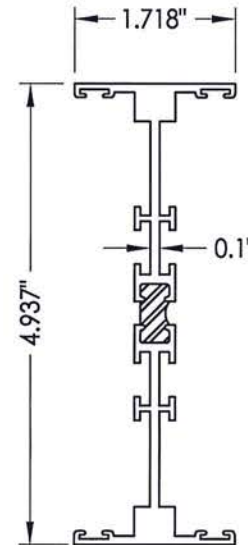

16 KONA I-MULLION

PRODUCT:		FLEETWOOD SPEC. 6, 6A	
PART OR ASSEMBLY:		COMPONENTS	
NO.	DATE	REVISIONS	BY
 RW BUILDING CONSULTANTS, INC. 813.659.9197			
DATE: 4/4/15			
SCALE: N.T.S.			
DWG. BY: JK			
CHK. BY: LFS			
DRAWING NO.: L-7349			
SHEET 16 OF 17			

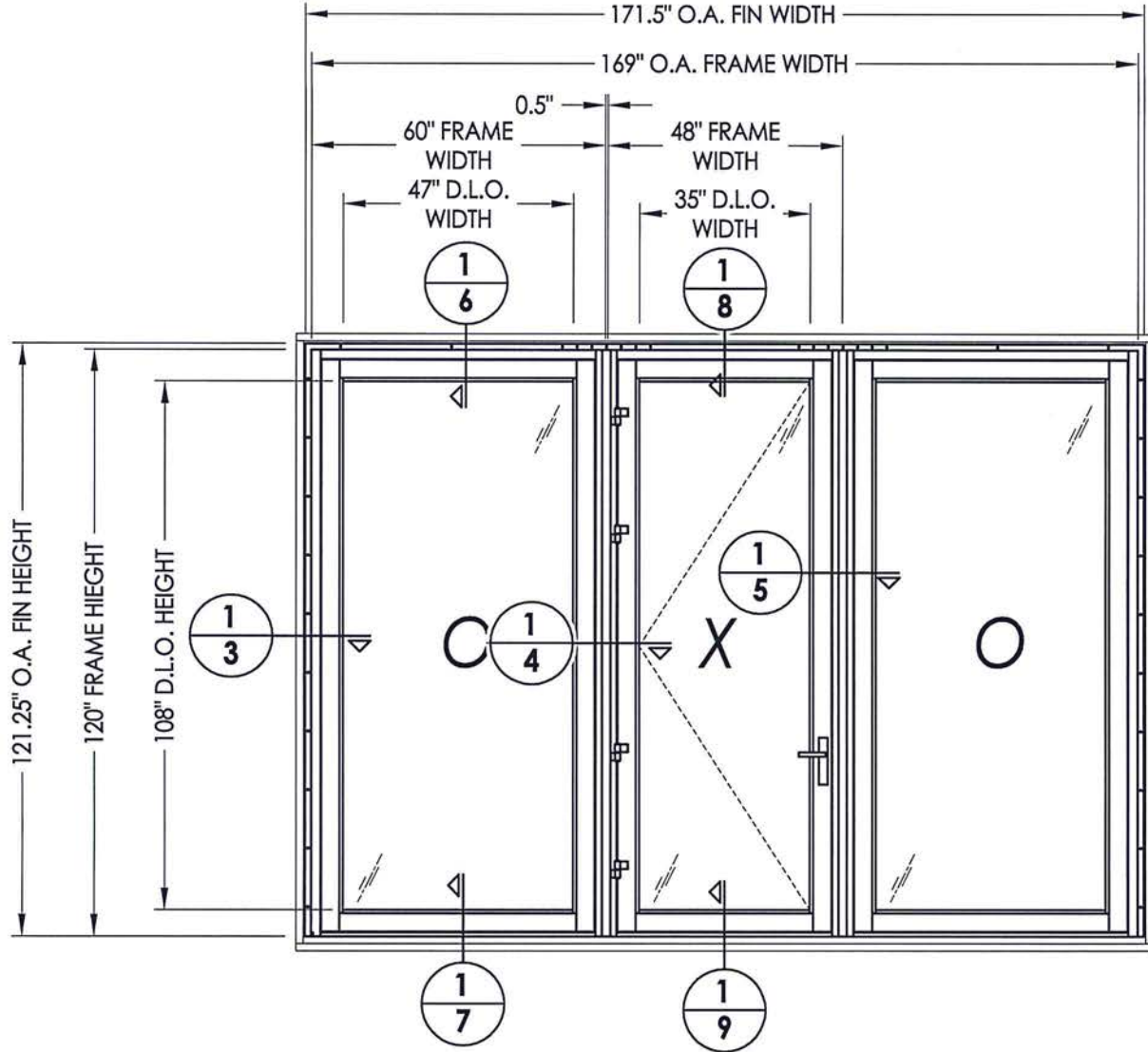

Testing Evaluation Laboratories Inc.
 Specimen Complies with Drawing
 Deviations Noted - TEL# 01991349
 Date 06/26/2015 Verified by *stw*

PRODUCT: FLEETWOOD SPEC. 6C, 6D, 6E		PART OR ASSEMBLY: TEST ELEVATIONS	
NO.	DATE	REVISIONS	BY
 RW BUILDING CONSULTANTS, INC. 813.659.9197			
DATE: 4/4/15			
SCALE: N.T.S.			
DWG. BY: JK			
CHK. BY: LFS			
DRAWING NO.: L-7349A			
SHEET <u>2</u> OF <u>14</u>			

Testing Evaluation Laboratories Inc.
 Specimen Complies with Drawing
 Deviations Noted - TEL# 01991349
 Date 06/26/2015 Verified by *[Signature]*

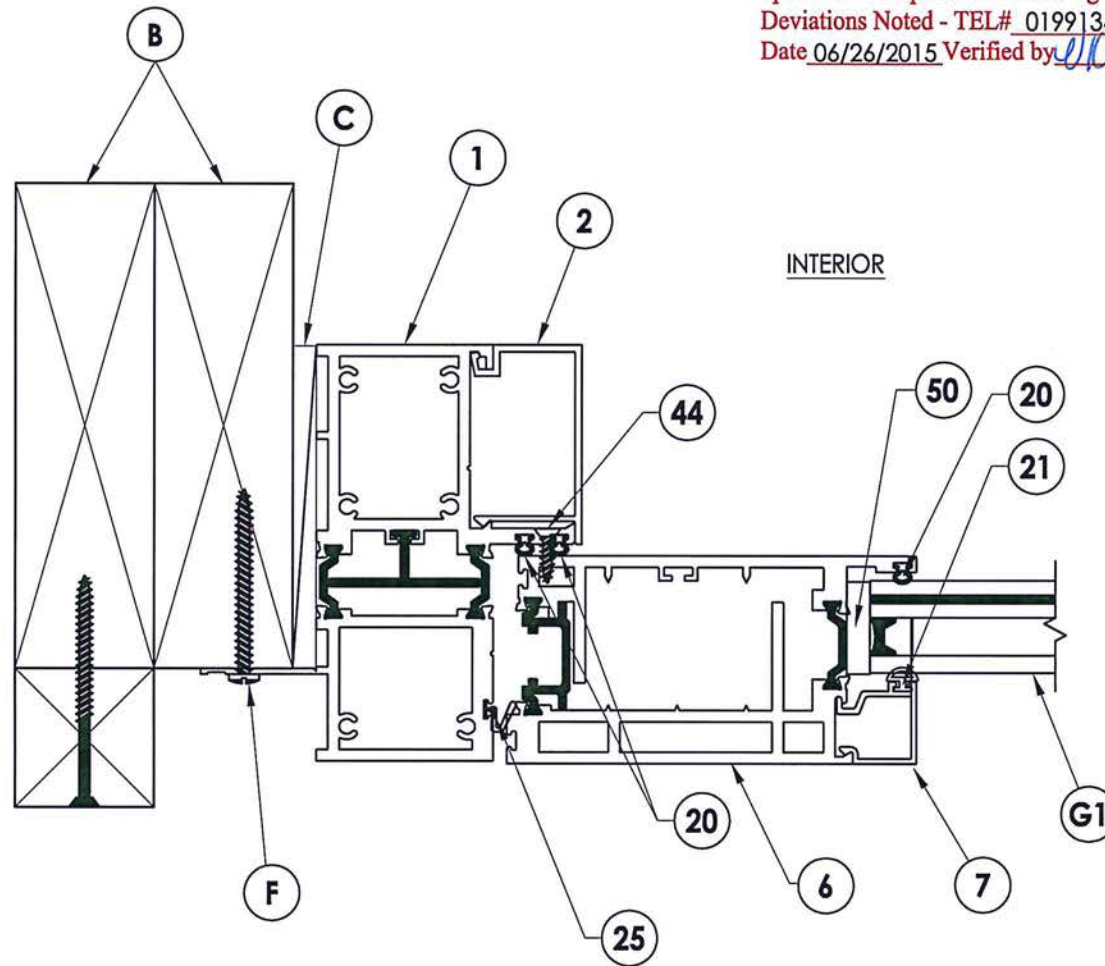

1
3 HORIZONTAL CROSS SECTION

PRODUCT: FLEETWOOD SPEC. 6C, 6D, 6E		PART OR ASSEMBLY: HORIZONTAL CROSS SECTIONS	
NO.	DATE	REVISIONS	BY
RW BUILDING CONSULTANTS, INC. 813.659.9197			
DATE: 4/4/15			
SCALE: N.T.S.			
DWG. BY: JK			
CHK. BY: LFS			
DRAWING NO.: L-7349A			
SHEET 3 OF 14			

Testing Evaluation Laboratories Inc.
 Specimen Complies with Drawing
 Deviations Noted - TEL# 01991349
 Date 06/26/2015 Verified by *[Signature]*

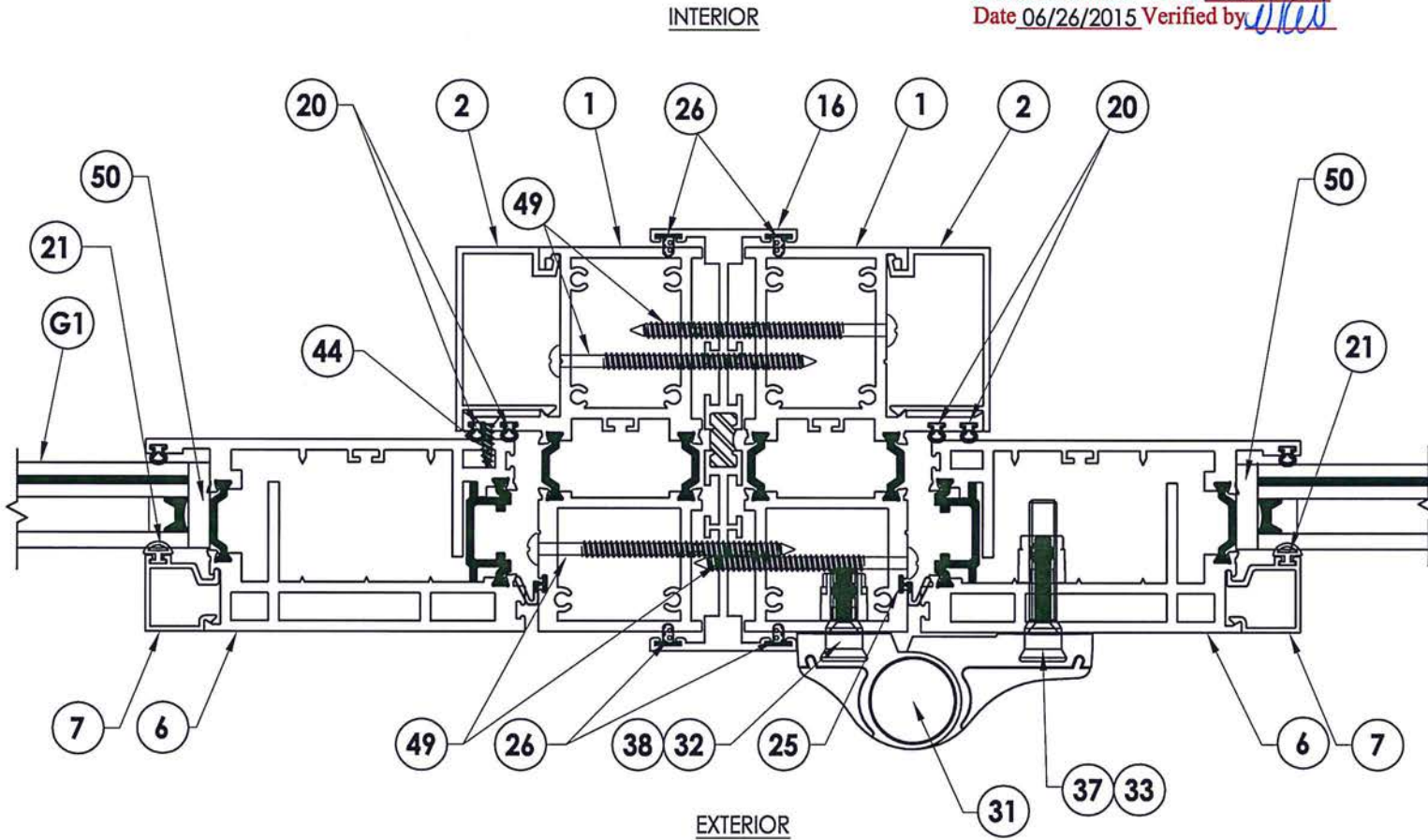

1
4 **HORIZONTAL CROSS SECTION**

PRODUCT: FLEETWOOD SPEC. 6C, 6D, 6E		PART OR ASSEMBLY: HORIZONTAL CROSS SECTIONS	
NO.	DATE	REVISIONS	BY
 RW BUILDING CONSULTANTS, INC. 813.659.9197			
DATE: 4/4/15			
SCALE: N.T.S.			
DWG. BY: JK			
CHK. BY: LFS			
DRAWING NO.: L-7349A			
SHEET 4 OF 14			

Testing Evaluation Laboratories Inc.
 Specimen Complies with Drawing
 Deviations Noted - TEL# 01991349
 Date 06/26/2015 Verified by *[Signature]*

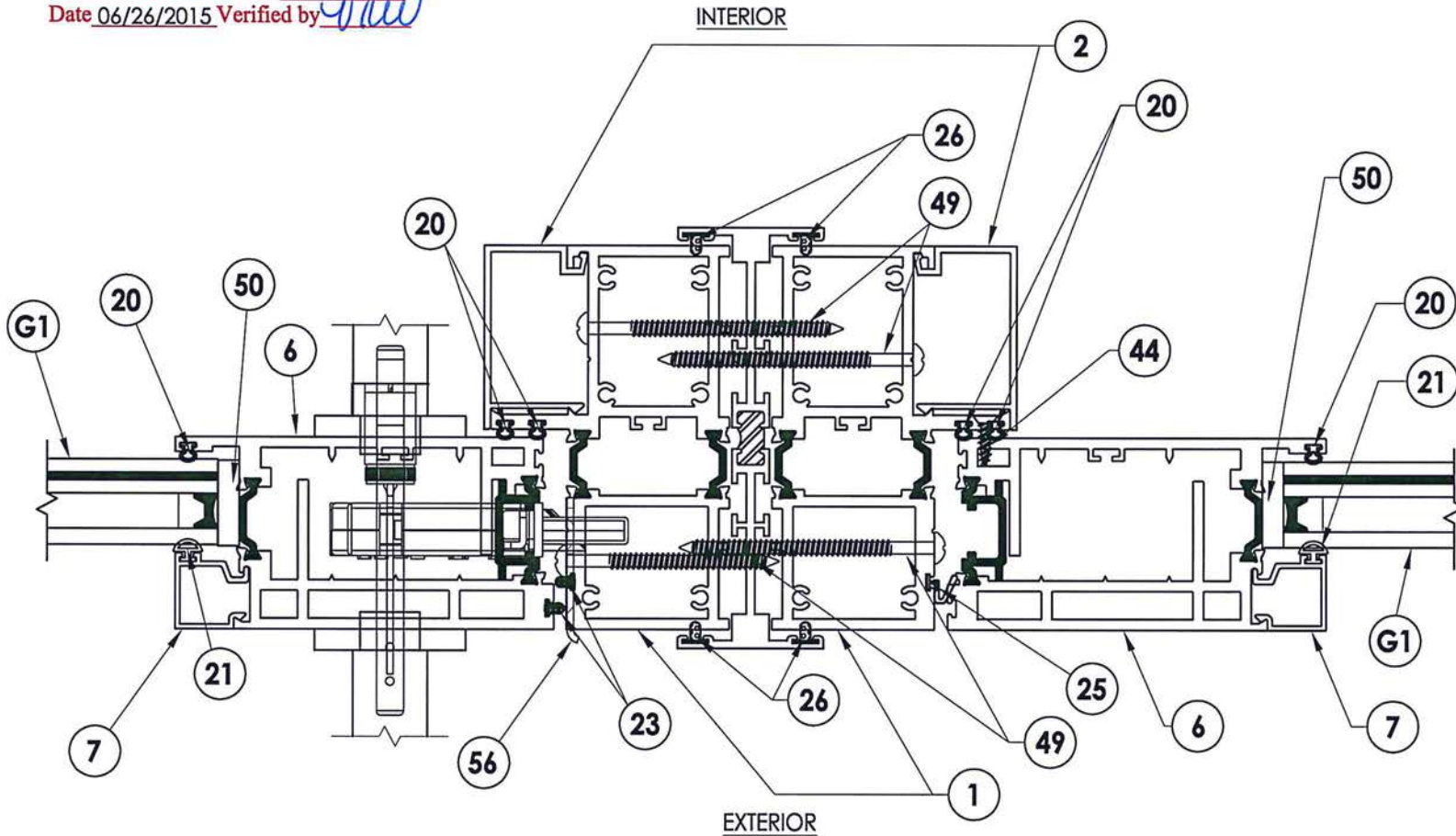

1 HORIZONTAL CROSS SECTION
5

PRODUCT: FLEETWOOD SPEC. 6C, 6D, 6E		PART OR ASSEMBLY: VERTICAL CROSS SECTIONS	
NO.	DATE	REVISIONS	BY
<div style="border: 1px solid black; padding: 5px;"> <p>RW BUILDING CONSULTANTS, INC. 813.659.9197</p> </div>			
DATE: 4/4/15			
SCALE: N.T.S.			
DWG. BY: JK			
CHK. BY: LFS			
DRAWING NO.: L-7349A			
SHEET 5 of 14			

Testing Evaluation Laboratories Inc.
 Specimen Complies with Drawing
 Deviations Noted - TEL# 01991349
 Date 06/26/2015 Verified by: *[Signature]*

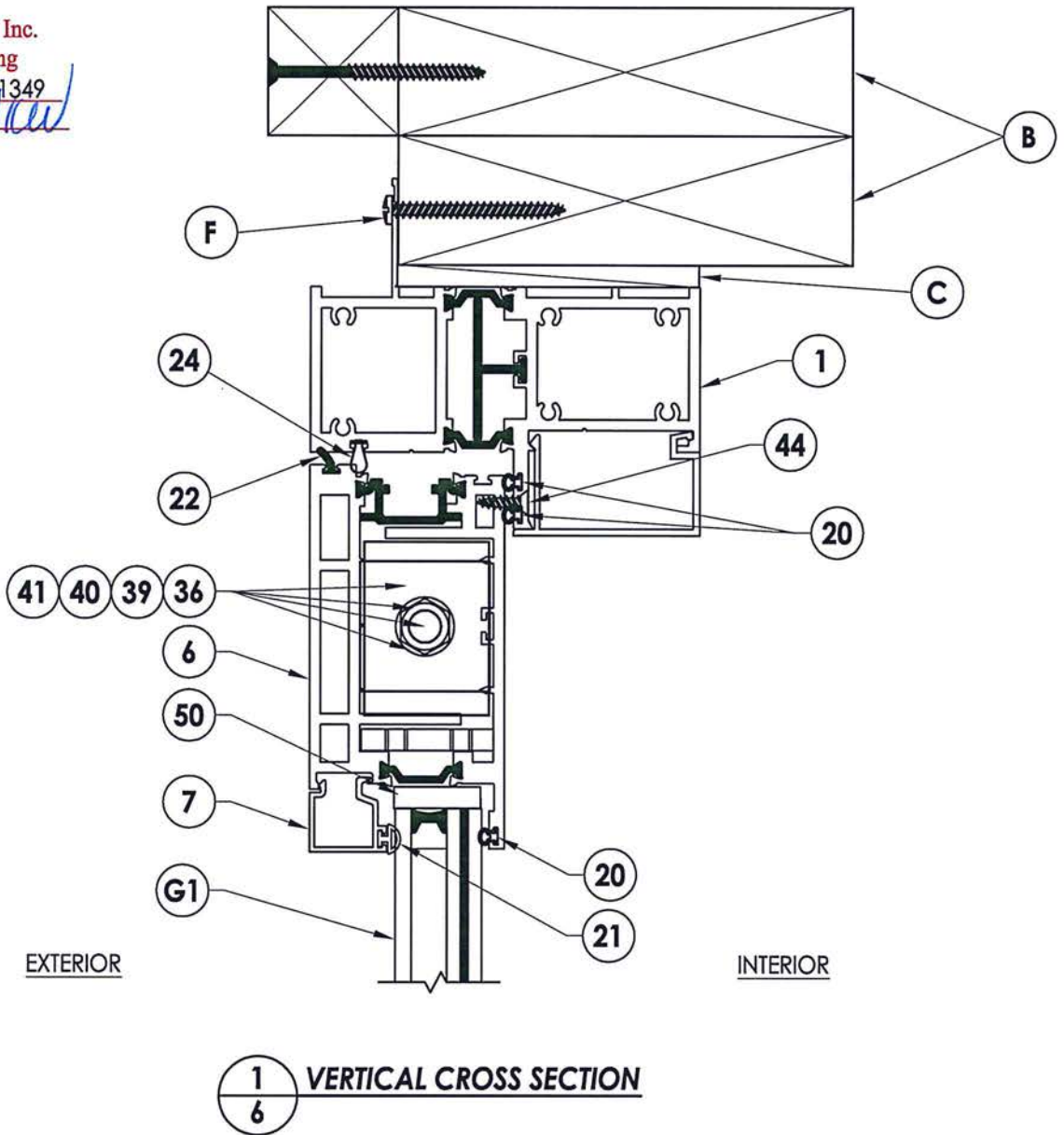

1
6 **VERTICAL CROSS SECTION**

PRODUCT: FLEETWOOD SPEC. 6C, 6D, 6E		PART OR ASSEMBLY: VERTICAL CROSS SECTIONS	
NO.	DATE	REVISIONS	BY
DATE: 4/4/15			
SCALE: N.T.S.			
DWG. BY: JK			
CHK. BY: LFS			
DRAWING NO.: L-7349A			
SHEET 6 OF 14			

Testing Evaluation Laboratories Inc.
 Specimen Complies with Drawing
 Deviations Noted - TEL# 01991349
 Date 06/26/2015 Verified by *[Signature]*

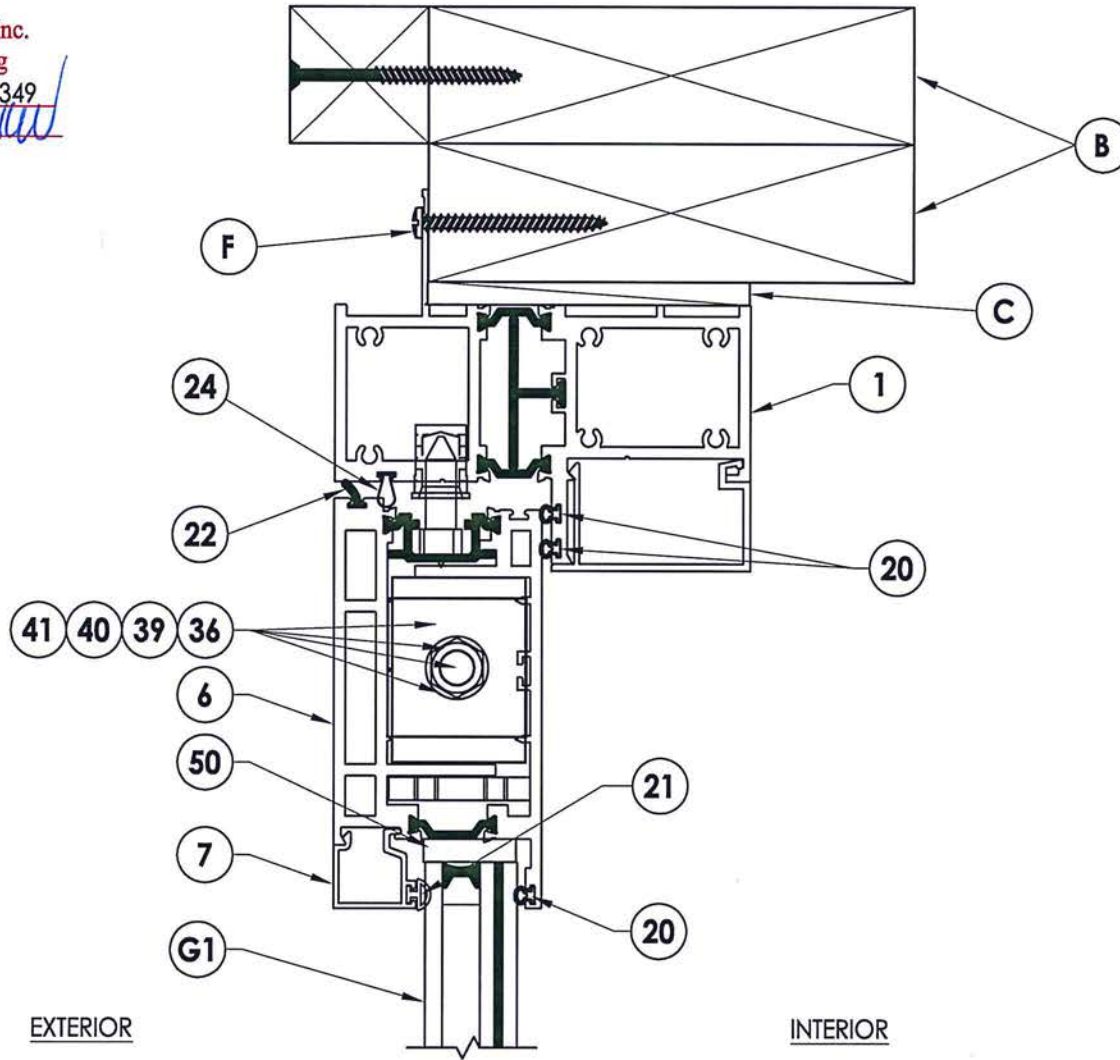

1
8 **VERTICAL CROSS SECTION**

PRODUCT: FLEETWOOD SPEC. 6C, 6D, 6E		PART OR ASSEMBLY: VERTICAL CROSS SECTIONS	
NO.	DATE	REVISIONS	BY
 R.W. BUILDING CONSULTANTS, INC. 813.659.9197			
DATE: 4/4/15			
SCALE: N.T.S.			
DWG. BY: JK			
CHK. BY: LFS			
DRAWING NO.: L-7349A			
SHEET 8 OF 14			



HINGE JAMB

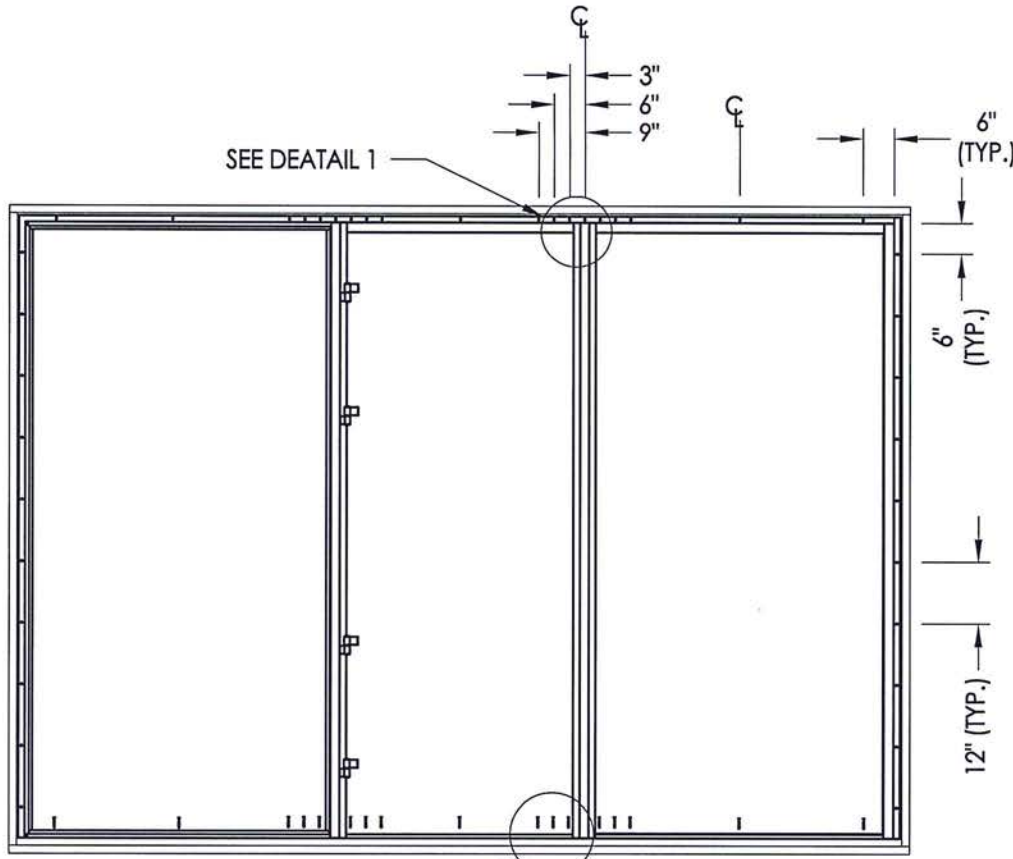

SEE DETAIL 2

SEE DETAIL 1

FRAME ANCHORING
(2X buck installation)

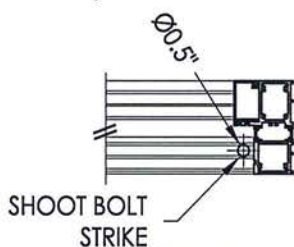

DETAIL 2

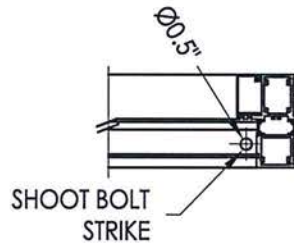

DETAIL 1

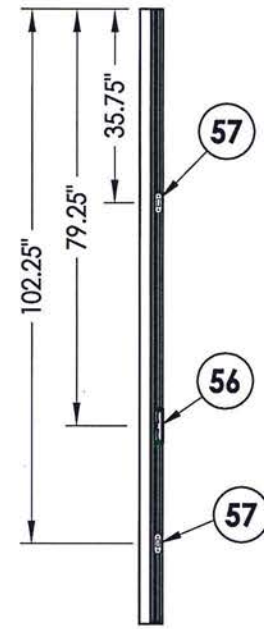



STRIKE JAMB

Testing Evaluation Laboratories Inc.
Specimen Complies with Drawing
Deviations Noted - TEL# 01991349
Date 06/26/2015 Verified by *[Signature]*

PRODUCT: FLEETWOOD SPEC: 6C, 6D, 6E		PART OR ASSEMBLY: FRAME ANCHORING	
NO.	DATE	REVISIONS	BY
 RW BUILDING CONSULTANTS, INC. 813.659.9197			
DATE: 4/4/15			
SCALE: N.T.S.			
DWG. BY: JK			
CHK. BY: LFS			
DRAWING NO.: L-7349A			
SHEET 10 OF 14			

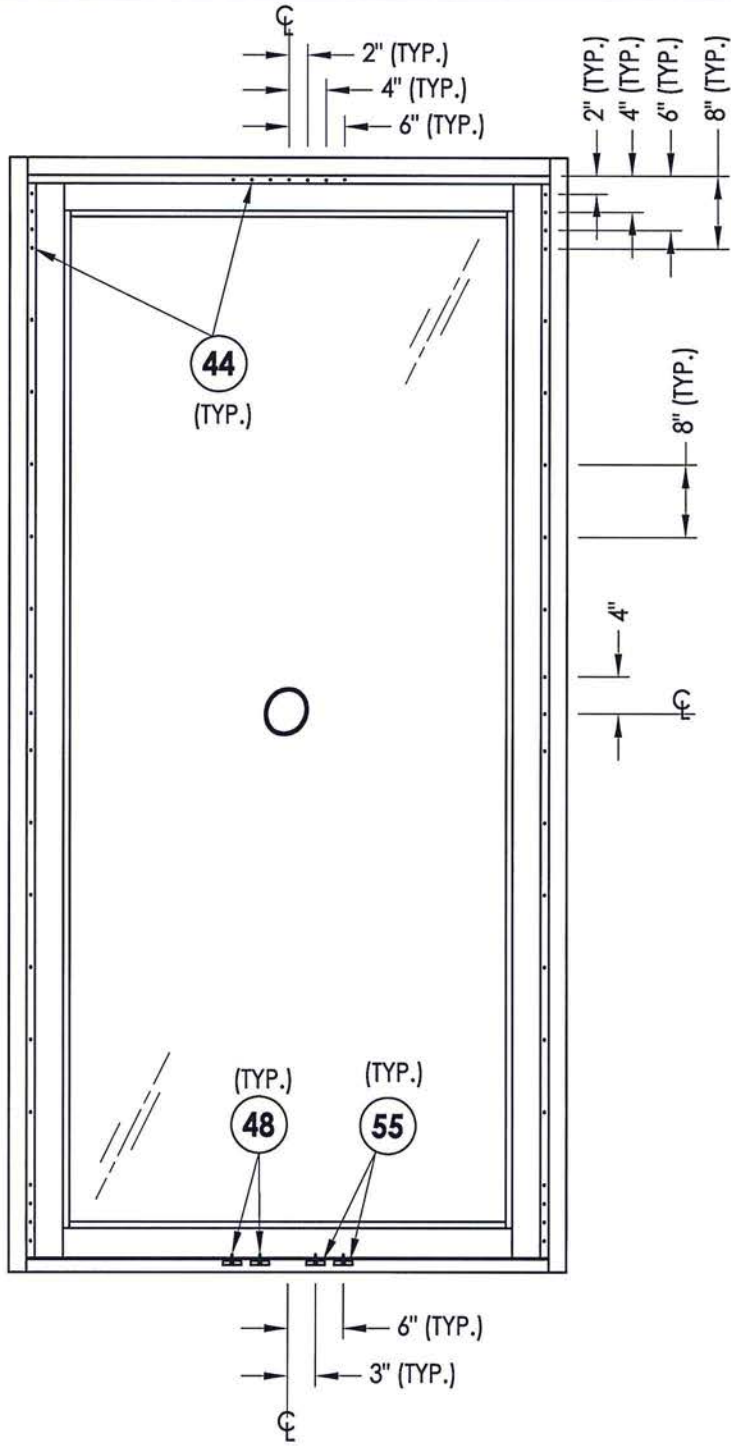
Testing Evaluation Laboratories Inc.
 Specimen Complies with Drawing
 Deviations Noted - TEL# 01991349
 Date 06/26/2015 Verified by *etel*



PRODUCT:		FLEETWOOD SPEC. 6C, 6D, 6E	
PART OR ASSEMBLY:		SIDELITE PANEL DETAIL	
NO.	DATE	REVISIONS	BY
 RW BUILDING CONSULTANTS, INC. 813.659.9197			
DATE: 4/4/15		SCALE: N.T.S.	
DWG. BY: JK		CHK. BY: LFS	
DRAWING NO.: L-7349A		SHEET 11 OF 14	

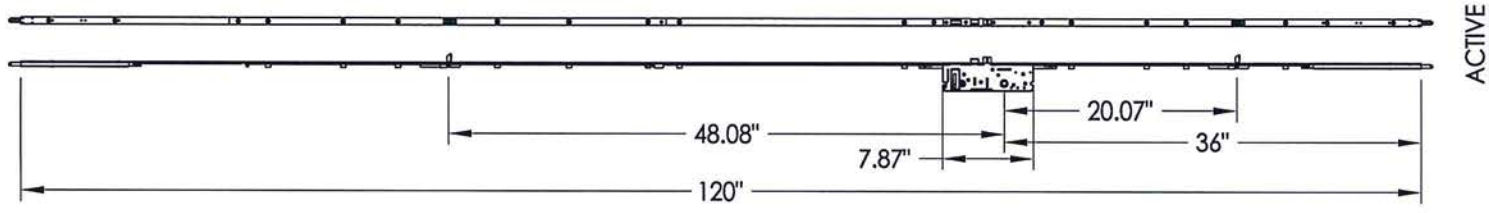

30 MULTI-POINT LOCK
TRUTH

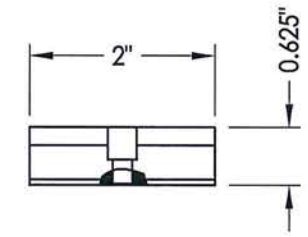

55 FIXED SILL BLOCK

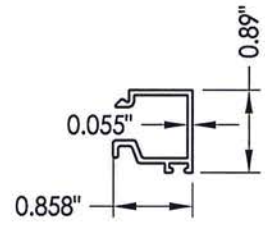

7 1" GLASS STOP

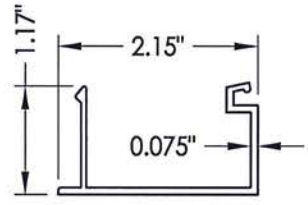

2 FRAME SNAP-IN

Testing Evaluation Laboratories Inc.
Specimen Complies with Drawing
Deviations Noted - TEL# 01991349
Date 06/26/2015 Verified by *[Signature]*

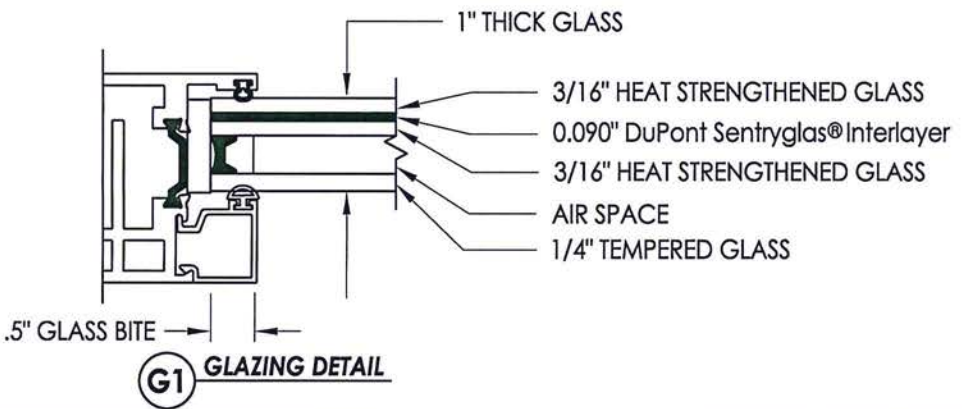

PRODUCT:		FLEETWOOD SPEC. 6C, 6D, 6E	
PART OR ASSEMBLY:		COMPONENTS AND GLAZING DETAIL	
NO.	DATE	REVISIONS	BY
DATE:		4/4/15	
SCALE:		N.T.S.	
DWG. BY:		JK	
CHK. BY:		LFS	
DRAWING NO.:		L-7349A	
SHEET		12 OF 14	

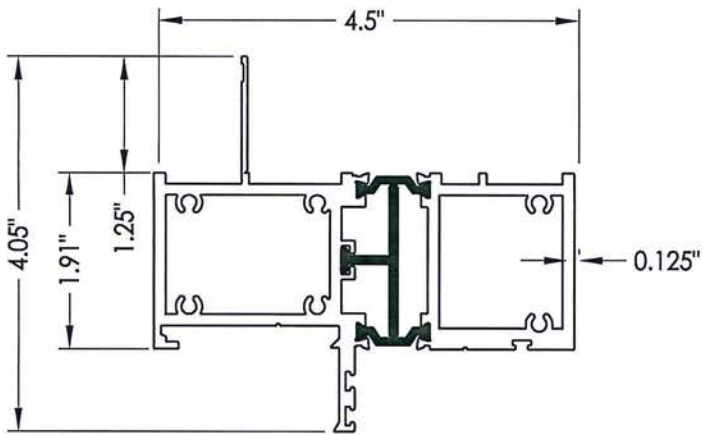

1 BLOCK HEAD & JAMBS
(Fin)

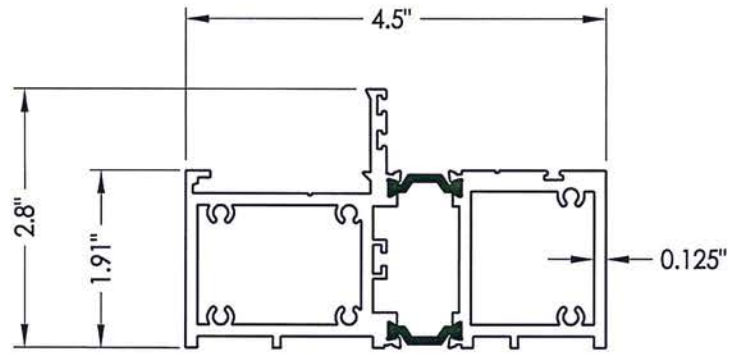

1 FRAME

Testing Evaluation Laboratories Inc.
Specimen Complies with Drawing
Deviations Noted - TEL# 01991349
Date 06/26/2015 Verified by *[Signature]*

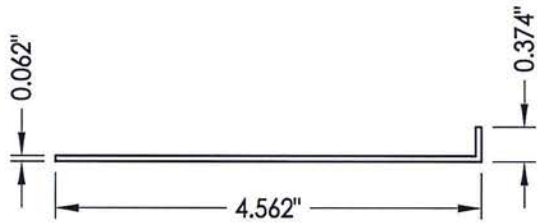

4 SILL PAN

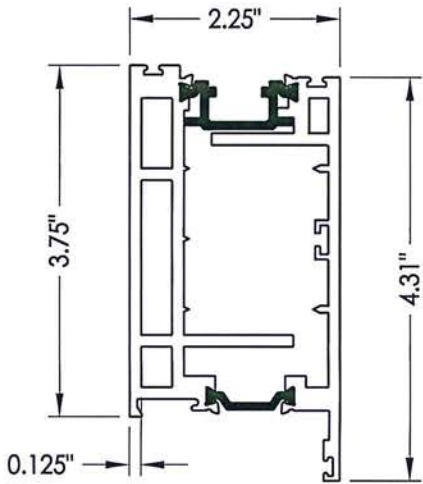

6 SASH

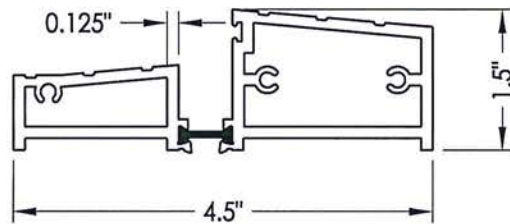

3 OUTSWING SILL

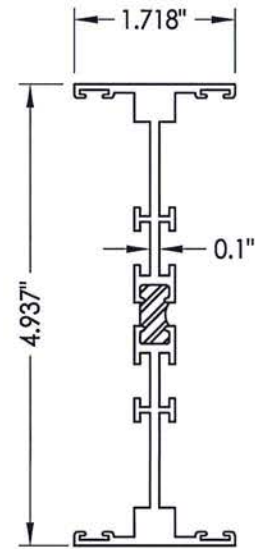

16 KONA I-MULLION

PRODUCT:		FLEETWOOD SPEC. 6C, 6D, 6E	
PART OR ASSEMBLY:		COMPONENTS	
NO.	DATE	REVISIONS	BY
 RW BUILDING CONSULTANTS, INC. 813.659.9197			
DATE: 4/4/15			
SCALE: N.T.S.			
DWG. BY: JK			
CHK. BY: LFS			
DRAWING NO.: L-7349A			
SHEET 13 OF 14			

