



FLEETWOOD
WINDOWS & DOORS
FleetwoodUSA.com

NORWOOD 3070EX M/S
XP CUSTOM CONFIGURATION
NO SCREENS

ORDER NO.:

ITEM NO.:

SCALE: 1/4

REQUIRED DEALER INFO.

A(DAYLIGHT WIDTH)

B(NET FRAME HEIGHT)

SILL PAN HEIGHT(INTERIOR LEG)
(3/4", 1-1/16", 1-7/16" OR 1-7/8")

CALCULATED VALUES (FLEETWOOD SUPPLIED)

C(POCKET WIDTH)

D(NET FRAME WIDTH)

NOTES:

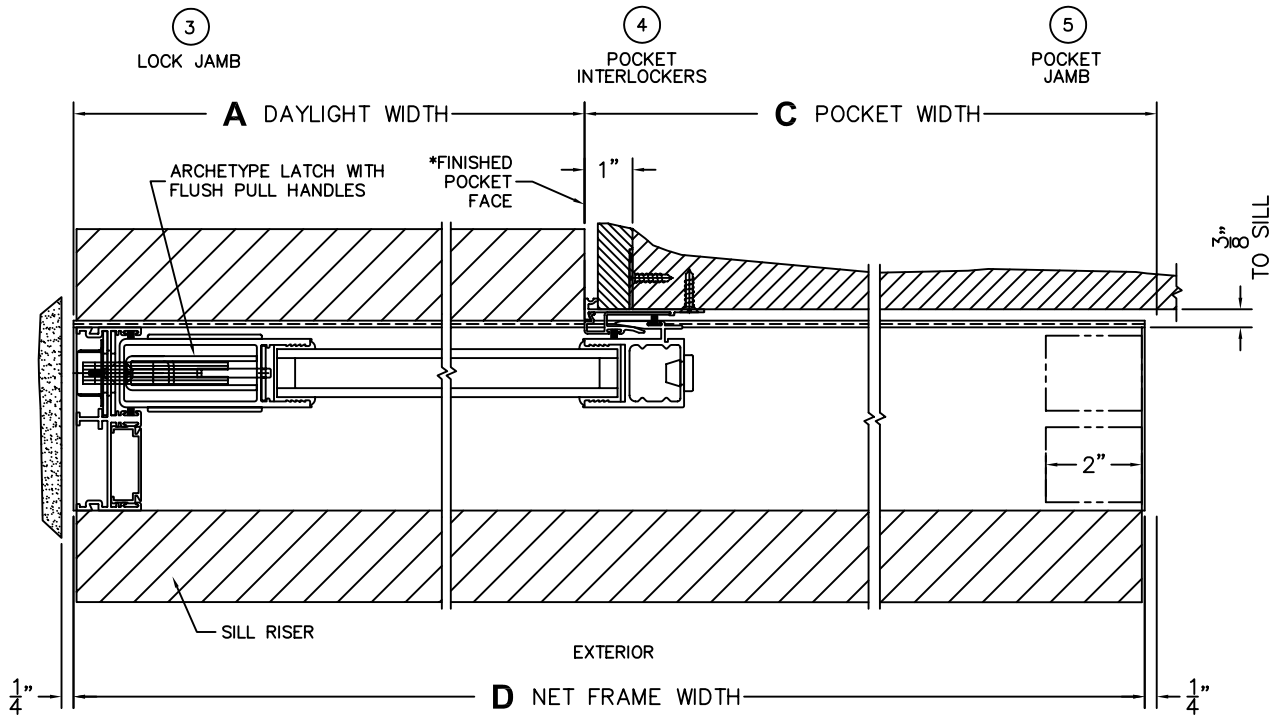
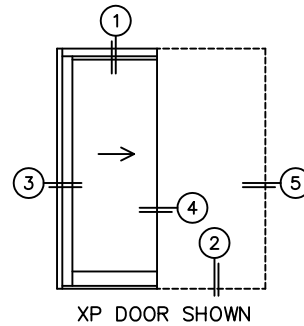
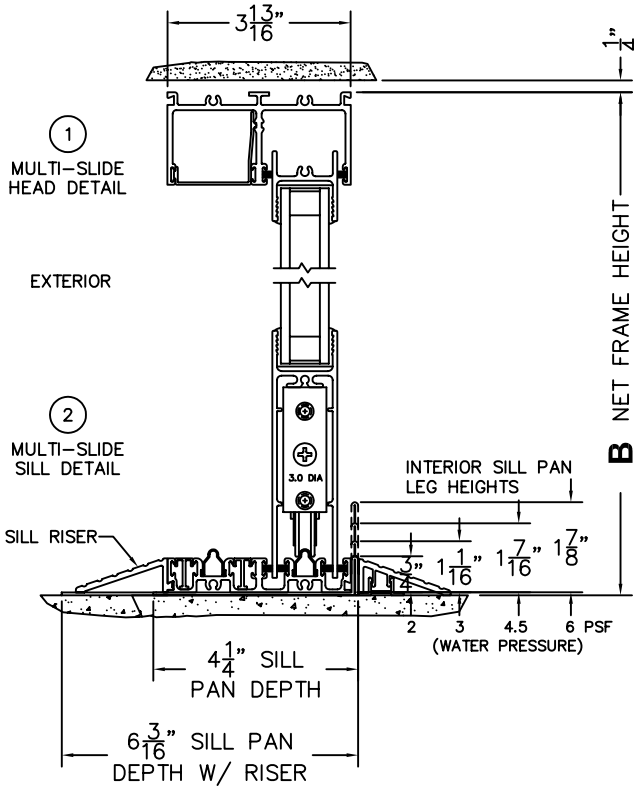

*CAUTION: WHEN CONSTRUCTING POCKET, NOTE THAT DAYLIGHT WIDTH DOES NOT INCLUDE 1" SET BACK FOR POST INTERLOCKER.



FLEETWOOD
 WINDOWS & DOORS
 FleetwoodUSA.com

NORWOOD 3070EX M/S
 XP CUSTOM CONFIGURATION
 NO SCREENS

ORDER NO.:

ITEM NO.:

SCALE: 1/4

POCKET VIEW: PANEL IN OPEN POSITION

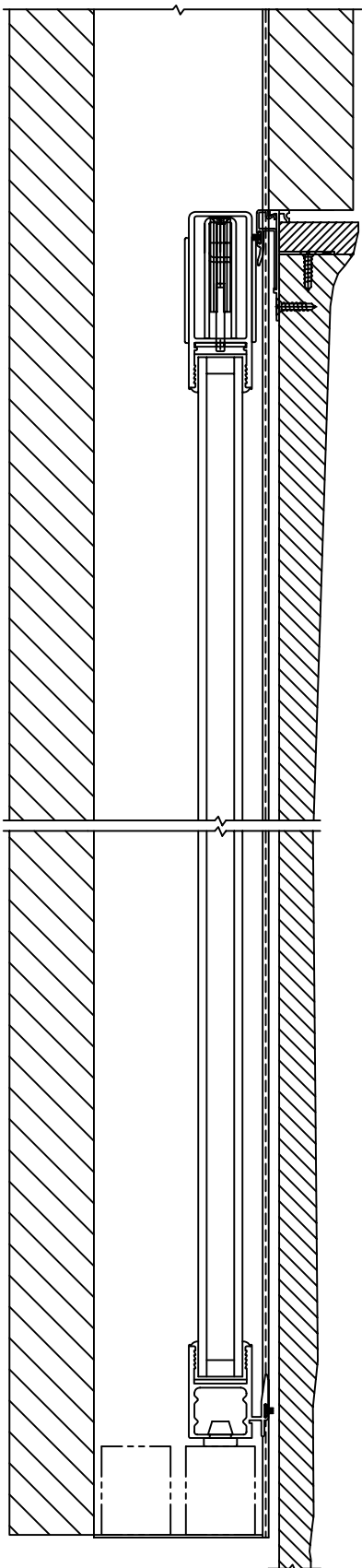

DWG NO.: 3070-EX-XP-SE0-IS-MS-SIE-HF-IN-AN-PEN-PN-P2-006-007

SHEET: 2 OF 2

CUSTOMER
SIGNATURE

DATE: