



ORDER NO.:

ITEM NO.:

REQUIRED DEALER INFO.

A(DAYLIGHT WIDTH)

B(NET FRAME HEIGHT)

SILL PAN HEIGHT (INTERIOR LEG)
(3/4", 1-1/16", 1-7/16" OR 1-7/8")

CALCULATED VALUES (FLEETWOOD SUPPLIED)

C(POCKET WIDTH)

D(NET FRAME WIDTH)

NOTES:

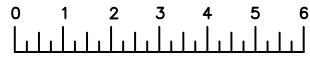

(USE RULER TO SCALE DIMENSIONS IN INCHES)

SCALE: 1/4

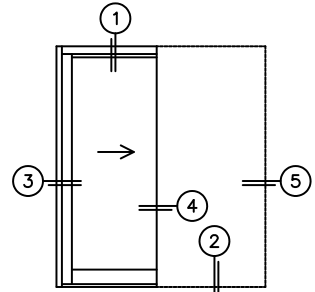
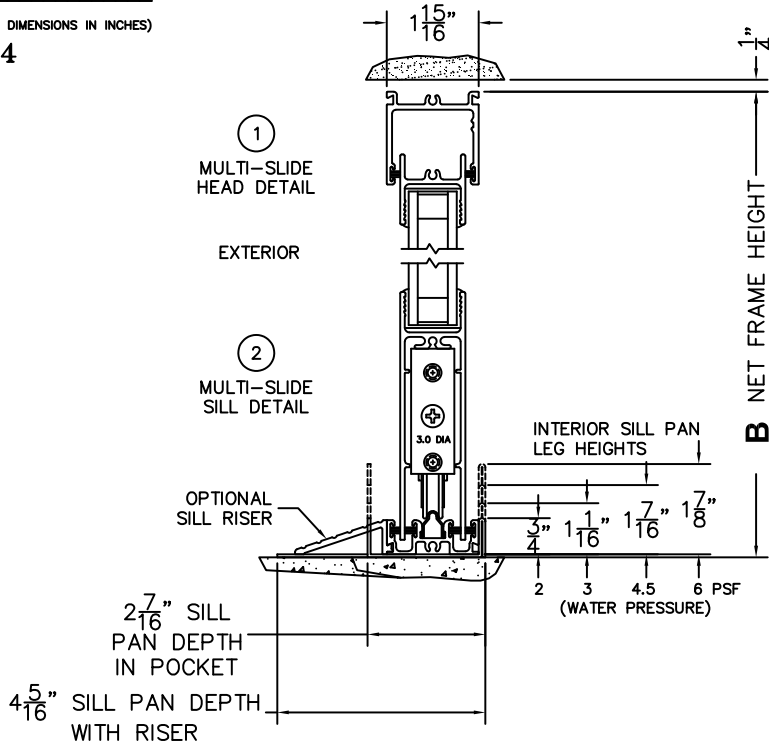

XP DOOR SHOWN

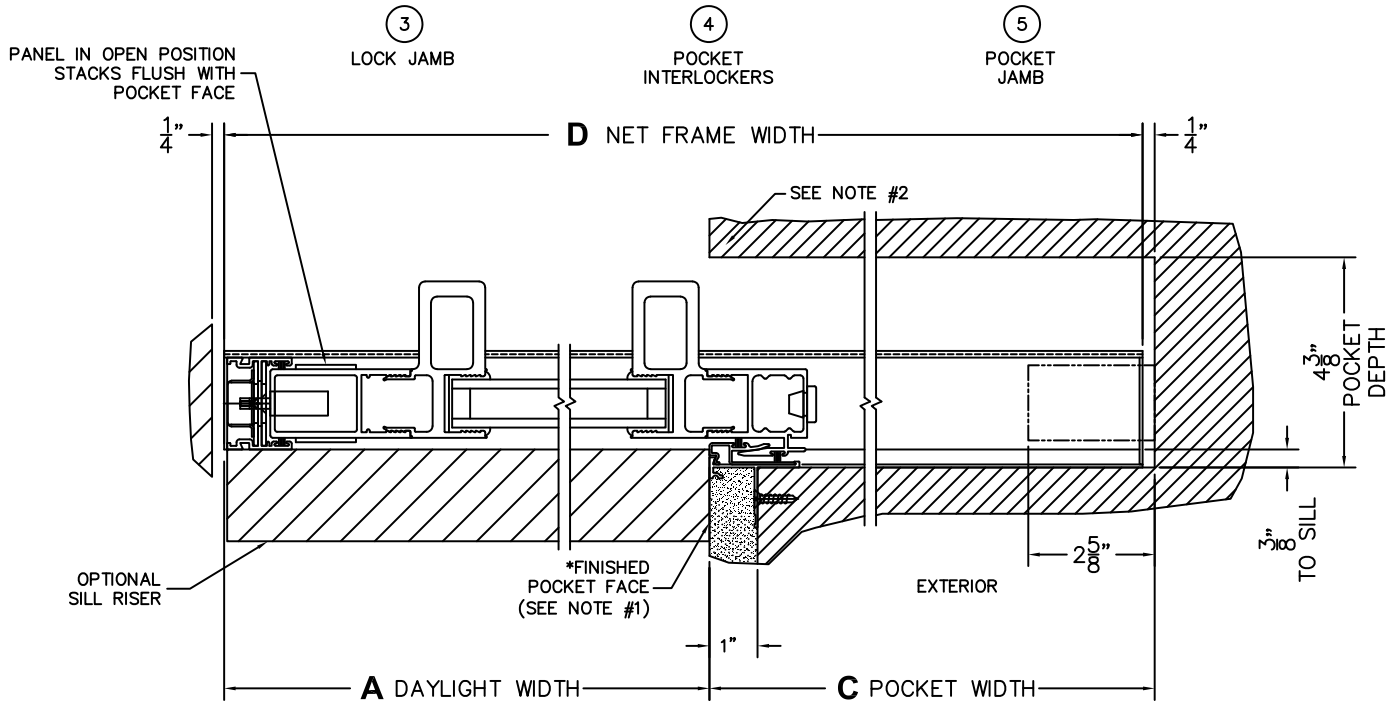

*NOTES:

- 1) WHEN CONSTRUCTING POCKET NOTE THAT DAYLIGHT WIDTH DOES NOT INCLUDE 1" SET BACK FOR POST INTERLOCKER.
- 2) TO ALLOW FUTURE REMOVAL OF PANEL THE INSTALLER MUST BUILD A FALSE WALL.