



**FLEETWOOD**  
WINDOWS & DOORS  
FleetwoodUSA.com

**NORWOOD 3070EX M/S**  
**XP STANDARD CONFIGURATION**  
**NO SCREENS**

ORDER NO.:

ITEM NO.:

REQUIRED DEALER INFO.

**A**(DAYLIGHT WIDTH)

**B**(NET FRAME HEIGHT)

SILL PAN HEIGHT (INTERIOR LEG)  
(3/4", 1-1/16", 1-7/16" OR 1-7/8")

CALCULATED VALUES (FLEETWOOD SUPPLIED)

**C**(POCKET WIDTH)

**D**(NET FRAME WIDTH)

NOTES:

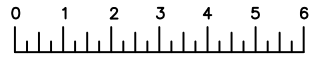

(USE RULER TO SCALE DIMENSIONS IN INCHES)

SCALE: 1/4

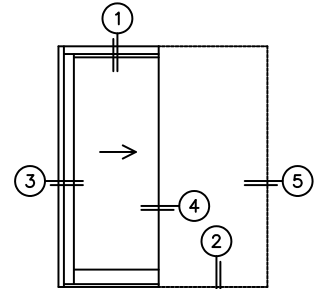
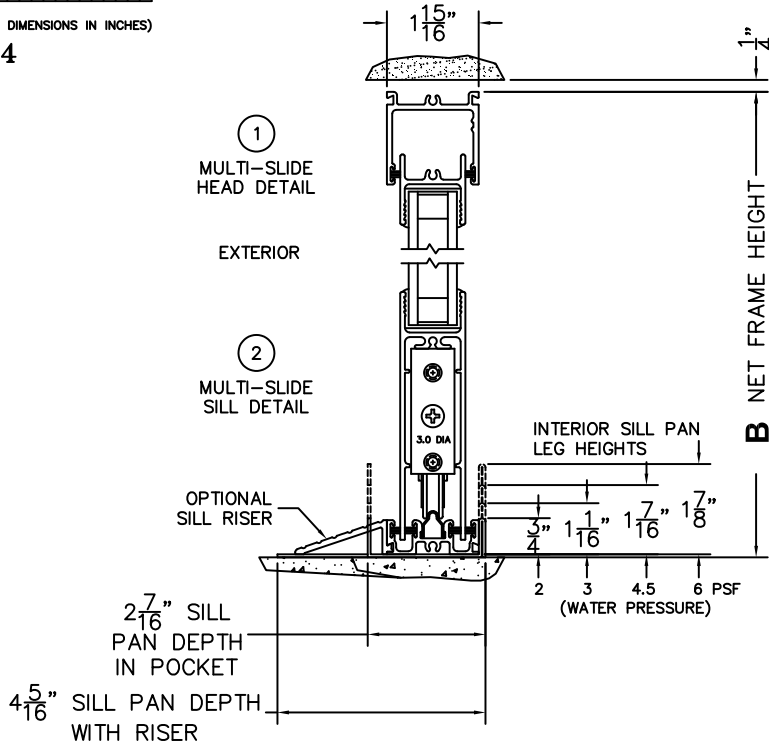

XP DOOR SHOWN

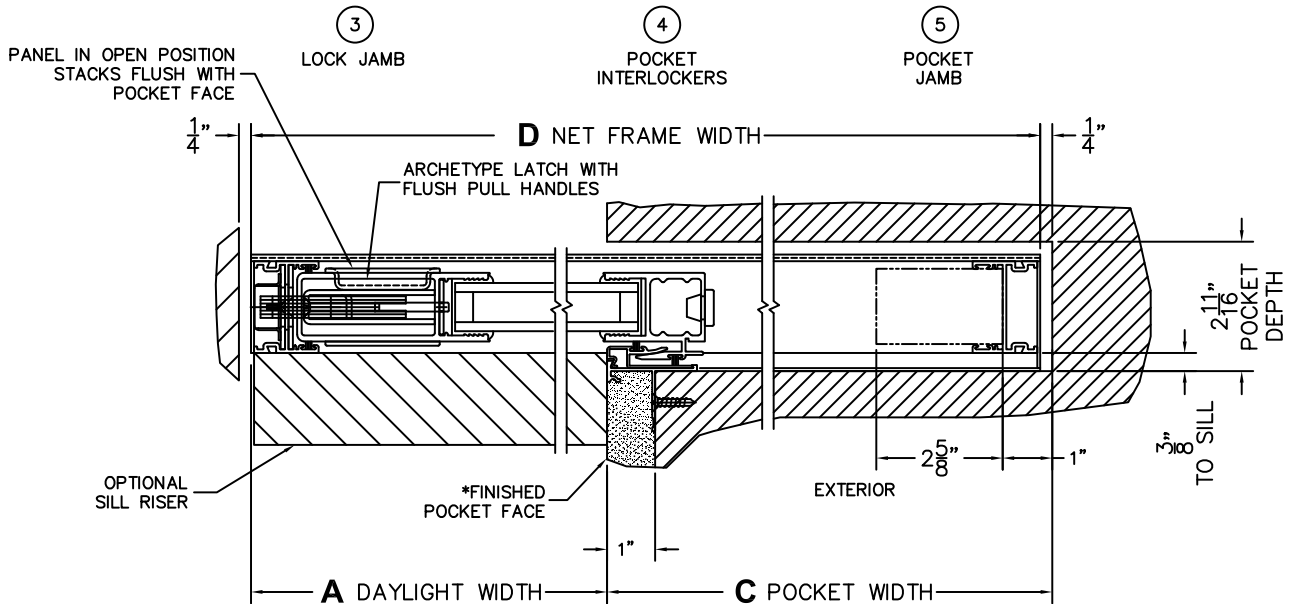

\*CAUTION: WHEN CONSTRUCTING POCKET NOTE THAT DAYLIGHT WIDTH DOES NOT INCLUDE 1" SET BACK FOR POST INTERLOCKER.