

ORDER NO.:

ITEM NO.:

REQUIRED DEALER INFO.

A (DAYLIGHT WIDTH)	
B (NET FRAME HEIGHT)	
SILL PAN HEIGHT (INTERIOR LEG) (3/4", 1-1/16", 1-7/16" OR 1-7/8")	

CALCULATED VALUES (FLEETWOOD SUPPLIED)

C (POCKET WIDTH)	
D (NET FRAME WIDTH)	

NOTES:

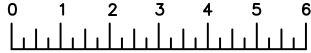

(USE RULER TO SCALE DIMENSIONS IN INCHES)

SCALE: 1/4

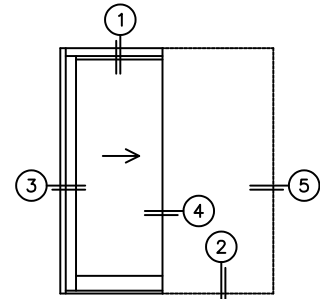
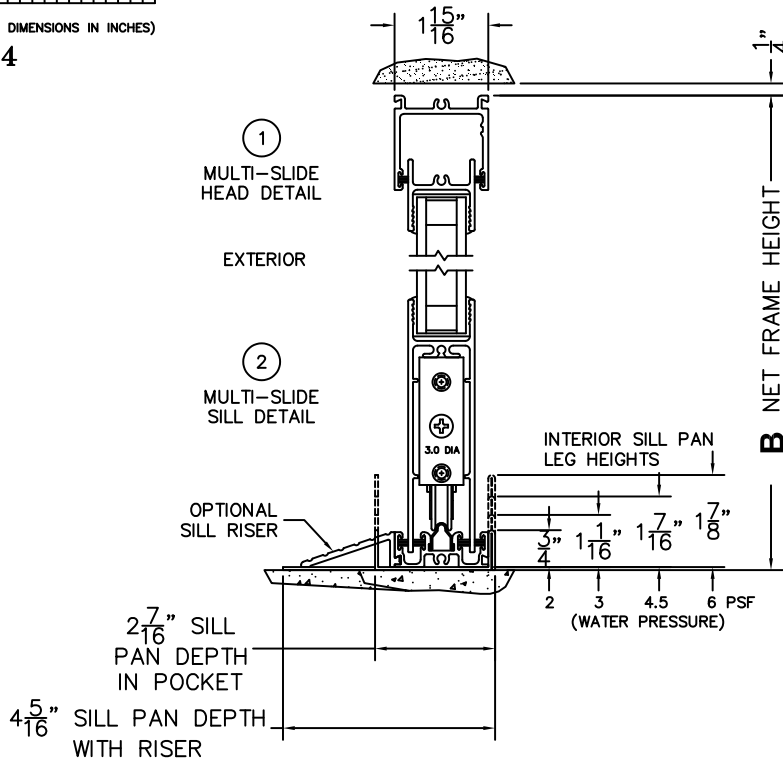

XP DOOR SHOWN

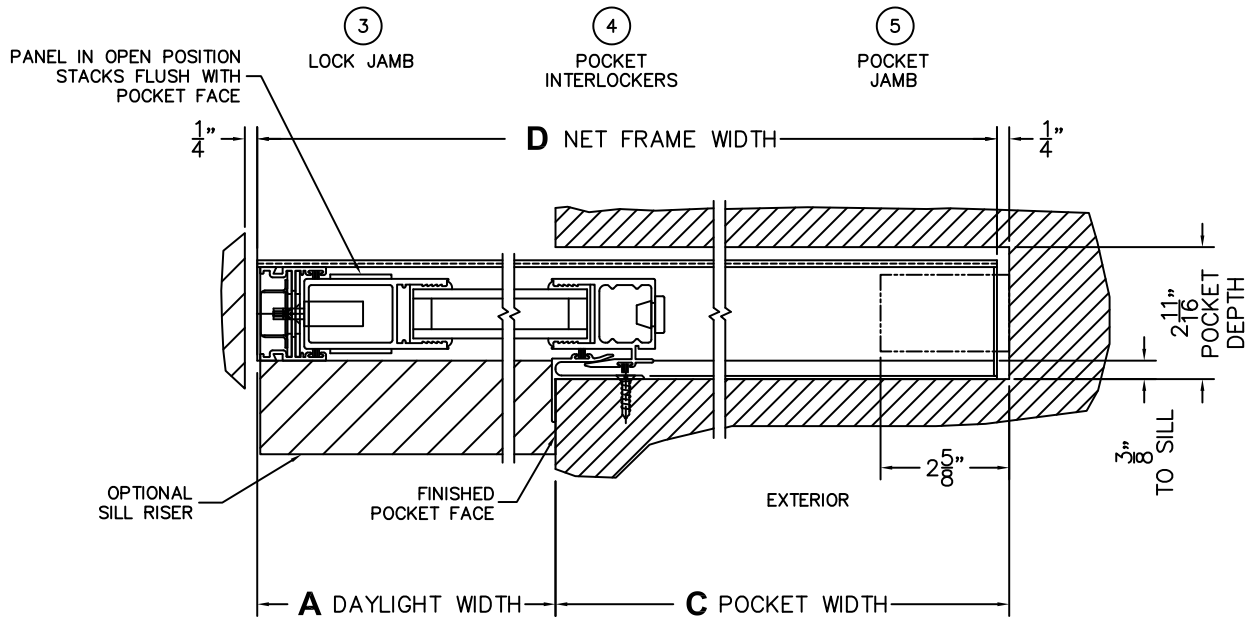

*NOTES:

- 1) TO ALLOW FUTURE REMOVAL OF PANEL THE INSTALLER MUST BUILD A FALSE WALL.