



FLEETWOOD
WINDOWS & DOORS
FleetwoodUSA.com

NORWOOD 3070EX M/S
PXIXP CUSTOM CONFIGURATION
WITH SCREENS

ORDER NO.:

ITEM NO.:

SCALE: 1/4

REQUIRED DEALER INFO.

A (DAYLIGHT WIDTH)	
B (NET FRAME HEIGHT)	
SILL PAN HEIGHT(INTERIOR LEG) (3/4", 1-1/16", 1-7/16" OR 1-7/8")	

CALCULATED VALUES (FLEETWOOD SUPPLIED)

C (POCKET WIDTH)	
D (NET FRAME WIDTH)	

NOTES:

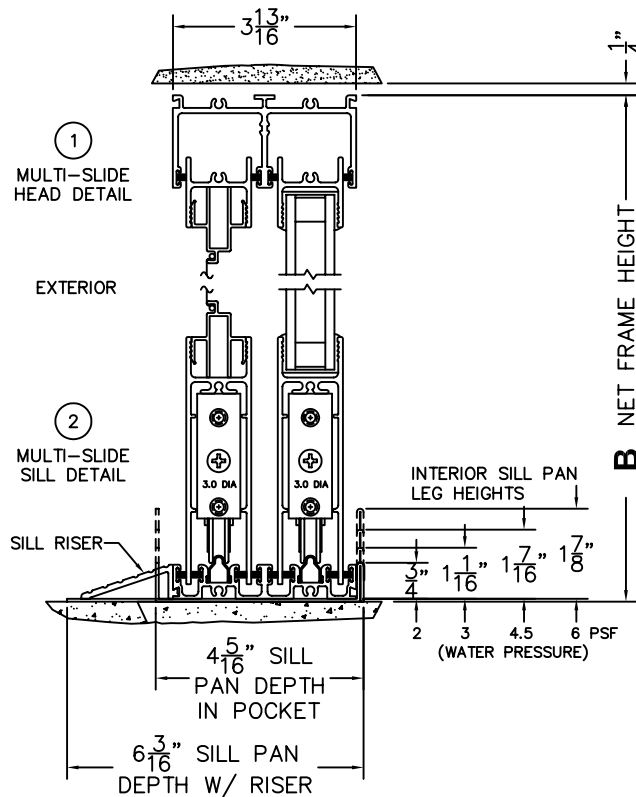
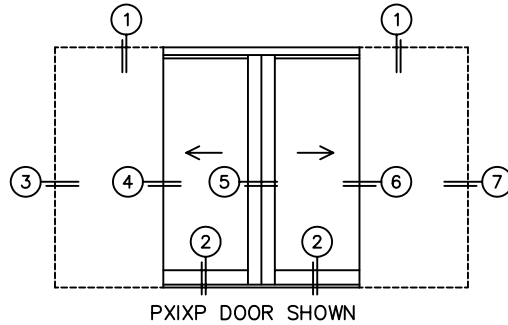



FLEETWOOD
WINDOWS & DOORS
FleetwoodUSA.com

NORWOOD 3070EX M/S
PX1XP CUSTOM CONFIGURATION
WITH SCREENS

ORDER NO.:

ITEM NO.:

SCALE: 1/4

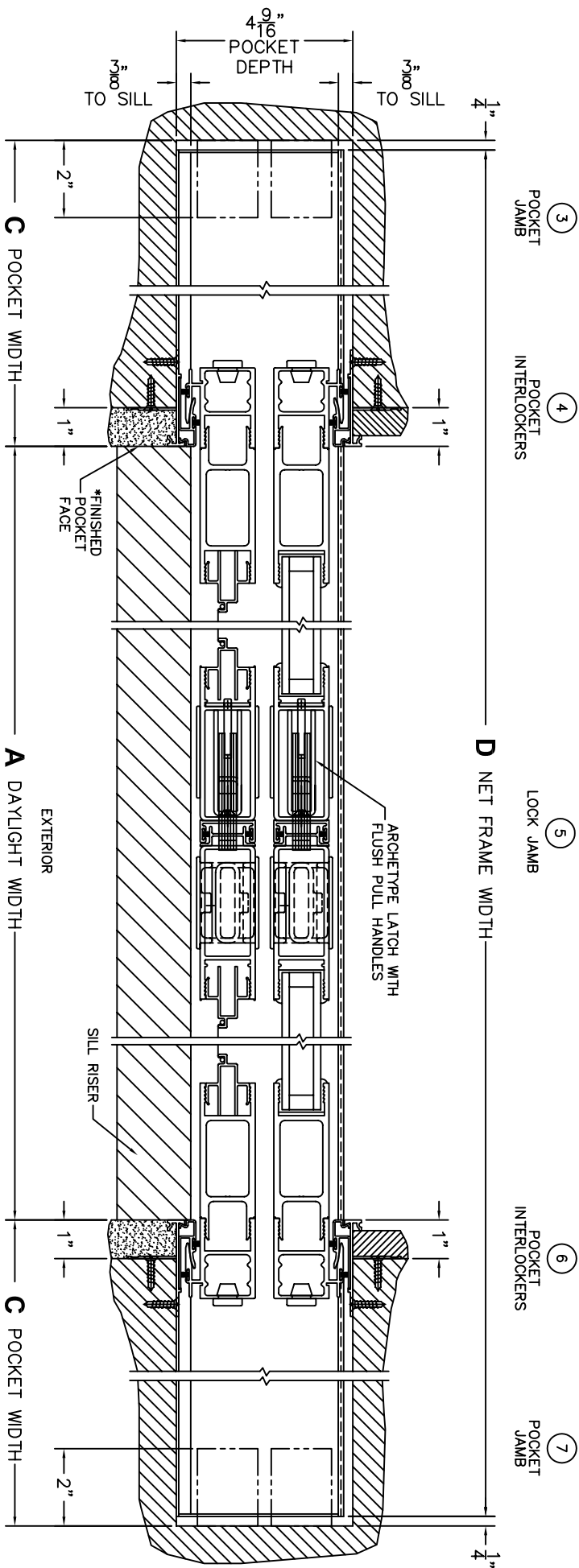

*CAUTION: WHEN CONSTRUCTING POCKET NOTE THAT DAYLIGHT WIDTH DOES NOT INCLUDE 1" SET BACK FOR POST INTERLOCKER.



FLEETWOOD
 WINDOWS & DOORS
 FleetwoodUSA.com

NORWOOD 3070EX M/S
 PXIXP CUSTOM CONFIGURATION
 WITH SCREENS

ORDER NO.:

ITEM NO.:

SCALE: 1/4

POCKET VIEWS: PANELS IN OPEN POSITION
 (LEFT SIDE)

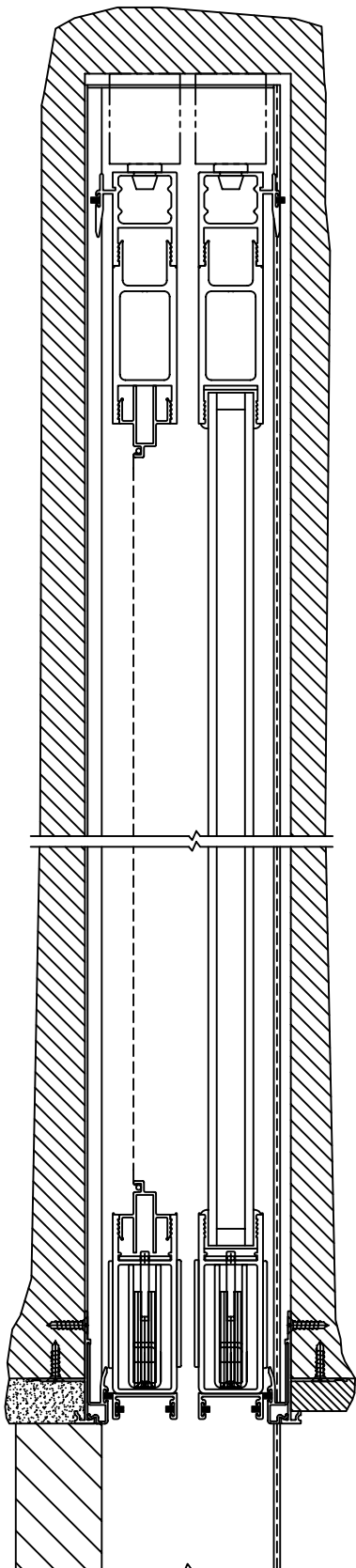

(RIGHT SIDE)

